

VSI OpenVMS

System Services Reference Manual: GETUTC-Z

Document Number: DO-DSSRFG-01A

Publication Date: April 2024

Operating System and Version: VSI OpenVMS IA-64 Version 8.4-1H1 or higher
VSI OpenVMS Alpha Version 8.4-2L1 or higher
VSI OpenVMS x86-64 Version 9.2-1 or higher

System Services Reference Manual: GETUTC–Z



VMS Software

Copyright © 2024 VMS Software, Inc. (VSI), Boston, Massachusetts, USA

Legal Notice

Confidential computer software. Valid license from VSI required for possession, use or copying. Consistent with FAR 12.211 and 12.212, Commercial Computer Software, Computer Software Documentation, and Technical Data for Commercial Items are licensed to the U.S. Government under vendor's standard commercial license.

The information contained herein is subject to change without notice. The only warranties for VSI products and services are set forth in the express warranty statements accompanying such products and services. Nothing herein should be construed as constituting an additional warranty. VSI shall not be liable for technical or editorial errors or omissions contained herein.

HPE, HPE Integrity, HPE Alpha, and HPE Proliant are trademarks or registered trademarks of Hewlett Packard Enterprise.

Intel, Itanium and IA-64 are trademarks or registered trademarks of Intel Corporation or its subsidiaries in the United States and other countries.

Preface	vii
1. About VSI	vii
2. Intended Audience	vii
3. System Services Support for OpenVMS Alpha 64-bit Addressing	vii
4. Related Documents	viii
5. VSI Encourages Your Comments	viii
6. OpenVMS Documentation	viii
7. Typographical Conventions	ix
System Service Descriptions	11
\$GETUTC	11
\$GET_ALIGN_FAULT_DATA (Alpha and Integrity servers)	12
\$GET_ARITH_EXCEPTION (Alpha Only)	14
\$GET_DEFAULT_TRANS	16
\$GET_GALAXY_LOCK_INFO (Alpha Only)	17
\$GET_GALAXY_LOCK_SIZE (Alpha Only)	20
\$GET_REGION_INFO (Alpha and Integrity servers)	21
\$GET_SECURITY	25
\$GET_SYS_ALIGN_FAULT_DATA (Alpha and Integrity servers)	33
\$GET_UNWIND_ENTRY_INFO (Integrity servers Only)	35
\$GET_USER_CAPABILITY (Alpha and Integrity servers)	36
\$GOTO_UNWIND (Alpha Only)	39
\$GOTO_UNWIND_64 (Alpha and Integrity servers)	41
\$GRANTID	43
\$HASH_PASSWORD	47
\$HIBER	50
\$ICC_ACCEPT	51
\$ICC_CLOSE_ASSOC	54
\$ICC_CONNECT	55
\$ICC_CONNECTW	61
\$ICC_DISCONNECT	62
\$ICC_DISCONNECTW	65
\$ICC_OPEN_ASSOC	65
\$ICC_RECEIVE	73
\$ICC_RECEIVEW	77
\$ICC_REJECT	77
\$ICC_REPLY	79
\$ICC_REPLYW	83
\$ICC_TRANSCEIVE	83
\$ICC_TRANSCEIVEW	87
\$ICC_TRANSMIT	87
\$ICC_TRANSMITW	90
\$IDTOASC	91
\$IEEE_SET_FP_CONTROL (Alpha and Integrity servers)	94
\$IEEE_SET_PRECISION_MODE (Integrity servers Only)	97
\$IEEE_SET_ROUNDING_MODE (Integrity servers Only)	98
\$INIT_SYS_ALIGN_FAULT_REPORT (Alpha and Integrity servers)	100
\$INIT_VOL	103
\$IO_CLEANUP (Alpha and Integrity servers)	118
\$IO_FASTPATH (Alpha and Integrity servers)	119
\$IO_FASTPATHW	121
\$IO_PERFORM (Alpha and Integrity servers)	121
\$IO_PERFORMW (Alpha and Integrity servers)	124

\$IO_SETUP (Alpha and Integrity servers)	124
\$JOIN_RM	128
\$JOIN_RMW	135
\$LCKPAG	135
\$LCKPAG_64 (Alpha and Integrity servers)	137
\$LKWSET	140
\$LKWSET_64 (Alpha and Integrity servers)	143
\$MGBLSC	147
\$MGBLSC_64 (Alpha and Integrity servers)	152
\$MGBLSC_GPFN_64 (Alpha and Integrity servers)	162
\$MOD HOLDER	168
\$MOD_IDENT	171
\$MOUNT	175
\$MTACCESS	190
\$NUMTIM	193
\$NUMUTC	194
\$NXTVOL	196
\$OPEN	196
\$PARSE	196
\$PARSE_ACL	196
\$PERM_DIS_ALIGN_FAULT_REPORT (Alpha and Integrity servers)	199
\$PERM_REPORT_ALIGN_FAULT (Alpha and Integrity servers)	200
\$PERSONA_ASSUME (Alpha and Integrity servers)	202
\$PERSONA_CLONE (Alpha and Integrity servers)	204
\$PERSONA_CREATE (Alpha and Integrity servers)	205
\$PERSONA_CREATE_EXTENSION (Alpha and Integrity servers)	211
\$PERSONA_DELEGATE (Alpha and Integrity servers)	214
\$PERSONA_DELETE	215
\$PERSONA_DELETE_EXTENSION (Alpha and Integrity servers)	217
\$PERSONA_EXTENSION_LOOKUP (Alpha and Integrity servers)	218
\$PERSONA_FIND (Alpha and Integrity servers)	220
\$PERSONA_MODIFY (Alpha and Integrity servers)	223
\$PERSONA_QUERY (Alpha and Integrity servers)	226
\$PERSONA_RESERVE (Alpha and Integrity servers)	230
\$POWER_CONTROL	232
\$PROCESS_AFFINITY (Alpha and Integrity servers)	233
\$PROCESS_CAPABILITIES (Alpha and Integrity servers)	238
\$PROCESS_SCAN	243
\$PURGWS	256
\$PURGE_WS (Alpha and Integrity servers)	258
\$PUT	259
\$PUTMSG	259
\$QIO	266
\$QIOW	272
\$READ	273
\$READEF	273
\$REGISTRY (Alpha and Integrity servers)	274
\$REGISTRYW (Alpha and Integrity servers)	300
\$RELEASE	301
\$RELEASE_GALAXY_LOCK (Alpha Only)	301
\$REMOVE	302
\$REM HOLDER	302

\$REM_IDENT	304
\$RENAME	306
\$RESCHED	306
\$RESUME	307
\$REVOKID	309
\$REWIND	313
\$RMSRUNDOWN	313
\$RPCC_64 (Alpha and Integrity servers)	315
\$SCAN_INTRUSION	315
\$SCHDWK	321
\$SCHED	324
\$SEARCH	329
\$SETAST	329
\$SETCLUEVT	330
\$SETDDIR	333
\$SETDFPROT	335
\$SETDTI	336
\$SETDTIW	343
\$SETEF	343
\$SETEXV	344
\$SETFLT	346
\$SETFLT_64	348
\$SETIME	351
\$SETIMR	353
\$SETPRA	355
\$SETPRI	357
\$SETPRN	361
\$SETPRT	363
\$SETPRT_64 (Alpha and Integrity servers)	366
\$SETPRV	369
\$SETRWM	373
\$SETSHLV	375
\$SETSTK	377
\$SETSTK_64 (Alpha and Integrity servers)	379
\$SETSWM	381
\$SETUAI	383
\$SETUP_AVOID_PREEMPT	397
\$SET_DEFAULT_TRANS	399
\$SET_DEFAULT_TRANSW	402
\$SET_DEVICE	403
\$SET_DEVICEW	407
\$SET_IMPLICIT_AFFINITY (Alpha and Integrity servers)	408
\$SET_PROCESS_PROPERTIESW (Alpha and Integrity servers)	411
\$SET_RESOURCE_DOMAIN	417
\$SET_RETURN_VALUE (Alpha and Integrity servers)	421
\$SET_SECURITY	423
\$SET_SYSTEM_EVENT (Alpha and Integrity servers)	431
\$SET_UNWIND_TABLE (Integrity servers Only)	434
\$SHOW_INTRUSION	437
\$SIGNAL_ARRAY_64	442
\$SNDERR	443
\$SNDJBC	444

\$SNDJBCW	505
\$SNDOPR	505
\$SPACE	518
\$START_ALIGN_FAULT_REPORT (Alpha and Integrity servers)	518
\$START_BRANCH	522
\$START_BRANCHW	529
\$START_TRANS	530
\$START_TRANSW	535
\$STOP_ALIGN_FAULT_REPORT (Alpha and Integrity servers)	536
\$STOP_SYS_ALIGN_FAULT_REPORT (Alpha and Integrity servers)	537
\$SUBSYSTEM	538
\$SUSPND	539
\$SYNCH	542
\$TIMCON	544
\$TRANS_EVENT	546
\$TRANS_EVENTW	551
\$TRNLNM	551
\$TRUNCATE	557
\$TSTCLUEVT	557
\$ULKPAG	559
\$ULKPAG_64 (Alpha and Integrity servers)	561
\$ULWSET	564
\$ULWSET_64 (Alpha and Integrity servers)	566
\$UNWIND	569
\$UPDSEC	571
\$UPDSECW	575
\$UPDSEC_64 (Alpha and Integrity servers)	576
\$UPDSEC_64W (Alpha and Integrity servers)	581
\$VERIFY_PROXY	581
\$WAIT	586
\$WAITFR	586
\$WAKE	587
\$WFLAND	589
\$WFLOR	591
\$WRITE	592
Appendix A. Obsolete Services	593

Preface

1. About VSI

VMS Software, Inc. (VSI) is an independent software company licensed by Hewlett Packard Enterprise to develop and support the OpenVMS operating system.

2. Intended Audience

This manual is intended for system and application programmers who want to call system services.

3. System Services Support for OpenVMS Alpha 64-bit Addressing

As of Version 7.0, the OpenVMS Alpha operating system provides support for 64-bit virtual memory addresses. This support makes the 64-bit virtual address space defined by the Alpha architecture available to the OpenVMS Alpha operating system and to application programs. In the 64-bit virtual address space, both process-private and system virtual address space extend beyond 2 GB. By using 64-bit address features, programmers can create images that map and access data beyond the previous limits of 32-bit virtual addresses.

New OpenVMS system services are available, and many existing services have been enhanced to manage 64-bit address space. The system services descriptions in this manual indicate the services that accept 64-bit addresses. A list of the OpenVMS system services that accept 64-bit addresses is available in the *VSI OpenVMS Programming Concepts Manual*.

The following section briefly describes how 64-bit addressing support affects OpenVMS system services. For complete information about OpenVMS Alpha 64-bit addressing features, refer to the *VSI OpenVMS Programming Concepts Manual*.

3.1. 64-Bit System Services Terminology

32-Bit System Service

A 32-bit system service only supports 32-bit addresses on any of its arguments that specify addresses. If passed by value on OpenVMS Alpha, a 32-bit virtual address is actually a 64-bit address that is sign-extended from 32 bits.

64-Bit Friendly Interface

A 64-bit friendly interface can be called with all 64-bit addresses. A 32-bit system service interface is 64-bit friendly if, without a change in the interface, it needs no modification to handle 64-bit addresses. The internal code that implements the system service might need modification, but the system service interface will not.

64-Bit System Service

A 64-bit system service is defined to accept all address arguments as 64-bit addresses (not necessarily 32-bit sign-extended values). A 64-bit system service also uses the entire 64 bits of all virtual addresses passed to it.

Use of the `_64` Suffix

The 64-bit system services include the `_64` suffix for services that accept 64-bit addresses by reference. For promoted services, this suffix distinguishes the 64-bit capable version from its 32-bit counterpart. For new services, it is a visible reminder that a 64-bit-wide address cell will be read/written.

3.2. Sign-Extension Checking

The OpenVMS system services that do not support 64-bit addresses and all user-written system services that are not explicitly enhanced to accept 64-bit addresses receive sign-extension checking. Any argument passed to these services that is not properly sign-extended causes the error status `SS$_ARG_GTR_32_BITS` to be returned.

4. Related Documents

The *VSI OpenVMS Programming Concepts Manual* contains useful information for anyone who wants to call system services.

High-level language programmers can find additional information about calling system services in the language reference manual and language user's guide provided with the OpenVMS language.

Application developers using XA-compliant or other resource managers should refer to the *VSI OpenVMS Programming Concepts Manual*.

The following documents might also be useful:

- *VSI OpenVMS Programming Concepts Manual*
- *VSI OpenVMS Guide to OpenVMS File Applications*
- *VSI OpenVMS Guide to System Security*
- *DECnet-Plus for OpenVMS Introduction and User's Guide*
- *VSI OpenVMS Record Management Services Reference Manual*
- *VSI OpenVMS I/O User's Reference Manual*
- *VSI OpenVMS Alpha Guide to Upgrading Privileged-Code Applications*

5. VSI Encourages Your Comments

You may send comments or suggestions regarding this manual or any VSI document by sending electronic mail to the following Internet address: `<docinfo@vmssoftware.com>`. Users who have VSI OpenVMS support contracts through VSI can contact `<support@vmssoftware.com>` for help with this product.

6. OpenVMS Documentation

The full VSI OpenVMS documentation set can be found on the VMS Software Documentation webpage at <https://docs.vmssoftware.com>.

7. Typographical Conventions

The following conventions are used in this manual:

Convention	Meaning
Ctrl/ <i>x</i>	A sequence such as Ctrl/ <i>x</i> indicates that you must hold down the key labeled Ctrl while you press another key or a pointing device button.
PF1 <i>x</i>	A sequence such as PF1 <i>x</i> indicates that you must first press and release the key labeled PF1 and then press and release another key (<i>x</i>) or a pointing device button.
. . .	A horizontal ellipsis in examples indicates one of the following possibilities: <ul style="list-style-type: none"> • Additional optional arguments in a statement have been omitted. • The preceding item or items can be repeated one or more times. • Additional parameters, values, or other information can be entered.
. . . .	A vertical ellipsis indicates the omission of items from a code example or command format; the items are omitted because they are not important to the topic being discussed.
()	In command format descriptions, parentheses indicate that you must enclose choices in parentheses if you specify more than one.
[]	In the <i>VSI OpenVMS System Services Reference Manual</i> , brackets generally indicate default arguments. If an argument is optional, it is specified as such in the argument text.
	In command format descriptions, vertical bars separate choices within brackets or braces. Within brackets, the choices are optional; within braces, at least one choice is required. Do not type the vertical bars on the command line.
{ }	In command format descriptions, braces indicate required choices; you must choose at least one of the items listed. Do not type the braces on the command line.
bold type	Bold type represents the name of an argument, an attribute, or a reason. Bold type also represents the introduction of a new term.
<i>italic type</i>	Italic type indicates important information, complete titles of manuals, or variables. Variables include information that varies in system output (Internal error <i>number</i>), in command lines (<i>/PRODUCER=name</i>), and in command parameters in text (where <i>dd</i> represents the predefined code for the device type).
UPPERCASE TYPE	Uppercase type indicates a command, the name of a routine, the name of a file, or the abbreviation for a system privilege.
Example	This typeface indicates code examples, command examples, and interactive screen displays. In text, this type also identifies URLs, UNIX commands and pathnames, PC-based commands and folders, and certain elements of the C programming language.
–	A hyphen at the end of a command format description, command line, or code line indicates that the command or statement continues on the following line.

Convention	Meaning
numbers	All numbers in text are assumed to be decimal unless otherwise noted. Nondecimal radices—binary, octal, or hexadecimal—are explicitly indicated.

System Service Descriptions

System services provide basic operating system functions, interprocess communication, and various control resources.

Condition values returned by system services indicate not only whether the service completed successfully, but can also provide other information. While the usual condition value indicating success is `SS$_NORMAL`, other values are also defined. For example, the condition value `SS$_BUFFEROVERF`, which is returned when a character string returned by a service is longer than the buffer provided to receive it, is a success code, but it also provides additional information.

Warning returns and some error returns indicate that the service might have performed some, but not all, of the requested function.

The particular condition values that each service can return are described in the Condition Values Returned section of each individual service description.

Returns

OpenVMS usage: `cond_value`
type: `longword (unsigned)`
access: `write only`
mechanism: `by value`

Longword condition value. All system services (except `$EXIT`) return by immediate value a condition value in `R0`.

\$GETUTC

Get UTC Time — Returns the current time in 128-bit UTC format. On Alpha and Integrity server systems, this service accepts 64-bit addresses.

Format

```
SYS$GETUTC utcadr
```

C Prototype

```
int sys$getutc (unsigned int *utcadr [4]);
```

Arguments

utcadr

OpenVMS usage: `coordinated universal time`
type: `utc_date_time`
access: `write only`
mechanism: `by 32- or 64-bit reference (Alpha and I64)`

The 128-bit time value to be returned.

Description

The Get UTC Time service returns the current system time in 128-bit UTC format. System time is updated every 10 milliseconds.

On Alpha and Integrity server systems, the frequency at which system time is updated varies, depending on the clock frequency of the Alpha or Integrity servers processor.

Required Access or Privileges

None

Required Quota

None

Related Services

\$ASCUTC, \$BINUTC, \$NUMUTC, \$TIMCON

Condition Values Returned

SS\$_NORMAL

The service completed successfully.

SS\$_ACCVIO

The argument was not accessible for write in the mode of the caller.

\$GET_ALIGN_FAULT_DATA (Alpha and Integrity servers)

Get Alignment Fault Data — On Alpha and Integrity server systems, obtains data from the user image alignment fault buffer if buffered user alignment fault data reporting has been enabled. This service accepts 64-bit addresses.

Format

```
SYSS$GET_ALIGN_FAULT_DATA buffer ,buffer_size ,return_size
```

C Prototype

```
int sys$get_align_fault_data  
    (void *buffer, int buffer_size, int *return_size);
```

Arguments

buffer

OpenVMS usage: address
type: longword (unsigned)
access: read/write
mechanism: by 32- or 64-bit reference

The user buffer in which the alignment fault data is to be stored. The *buffer* is the 32- or 64-bit address of this user buffer.

buffer_size

OpenVMS usage: byte count
type: longword (signed)
access: read
mechanism: by value

The size, in bytes, of the buffer specified by the *buffer* argument.

return_size

OpenVMS usage: longword_signed
type: longword (signed)
access: write
mechanism: by 32- or 64-bit reference

The amount of data, in bytes, stored in the buffer. The *return_size* argument is the 32- or 64-bit address of a naturally aligned longword into which the service returns the size of the buffer. The **return_size** is set to 0 if there is no data in the buffer.

Description

The Get Alignment Fault Data service obtains data from the user image alignment fault buffer if buffered user alignment fault data reporting has been enabled.

When buffered user alignment fault data reporting is enabled, the operating system writes each alignment fault into a user-defined buffer. The user must poll this buffer periodically to read the data.

The user must call the \$START_ALIGN_FAULT_REPORT service to enable buffered user alignment fault data reporting.

For more information about buffered user alignment fault data reporting, see the \$START_ALIGN_FAULT_REPORT system service.

Required Access or Privileges

None

Required Quota

None

Related Services

\$GET_SYS_ALIGN_FAULT_DATA, \$INIT_SYS_ALIGN_FAULT_REPORT,
\$PERM_DIS_ALIGN_FAULT_REPORT, \$PERM_REPORT_ALIGN_FAULT,
\$START_ALIGN_FAULT_REPORT, \$STOP_ALIGN_FAULT_REPORT,
\$STOP_SYS_ALIGN_FAULT_REPORT

Condition Values Returned

SS\$_NORMAL

The service completed successfully.

SS\$_ACCVIO

The buffer named in the *buffer* argument is not accessible.

SS\$_AFR_NOT_ENABLED

Alignment fault reporting has not been enabled.

SS\$_BADPARAM

The buffer size is smaller than the minimum defined by the AFR\$K_USER_LENGTH symbol.

\$GET_ARITH_EXCEPTION (Alpha Only)

Get Arithmetic Exception Information — On Alpha systems, returns information about the exception context for a given arithmetic exception. There are two forms the signal argument vectors: one for use with 32-bit addresses and one for use with 64-bit addresses.

For more information, see the *VSI OpenVMS Calling Standard*.

Format

```
SYSS$GET_ARITH_EXCEPTION sigarg ,mcharg ,buffer
```

C Prototype

```
int sys$get_arith_exception  
    (void *sigarg, void *mcharg, void *buffer);
```

Arguments

sigarg

OpenVMS usage: signal array
type: vector_longword_signed
access: read only
mechanism: by reference

Address of the signal array for the given arithmetic exception.

mcharg

OpenVMS usage: mech array
type: vector_quadword_unsigned
access: read only
mechanism: by reference

Address of the mechanism array for the given arithmetic exception.

buffer

OpenVMS usage: vector_quadword
type: vector_quadword_unsigned
access: write only
mechanism: by descriptor

Four-quadword buffer to receive additional exception context. The *buffer* argument is the address of a descriptor that points to this buffer.

Description

The Get Arithmetic Exception Information service returns, to the buffer specified by the *buffer* argument, the following information for a given arithmetic exception in an array of quadwords:

- First quadword, the PC of the triggering instruction in the trap shadow
- Second quadword, a copy of the triggering instruction
- Third quadword, the exception summary
- Fourth quadword, the register write mask

Required Access or Privilege

None

Required Quota

None

Condition Values Returned

SS\$_NORMAL

The service completed successfully.

SS\$_ACCVIO

The specified buffer cannot be written.

SS\$_BADBUFLN

The specified buffer length is invalid or out of range.

\$GET_DEFAULT_TRANS

Get Default Transaction — Returns the default transaction of the calling process.

Format

```
SYS$GET_DEFAULT_TRANS tid
```

C Prototype

```
int sys$get_default_trans (unsigned int tid [4]);
```

Arguments

tid

OpenVMS usage: trans_id
type: octaword (unsigned)
access: write only
mechanism: by reference

Address of an octaword in which the identifier (TID) of the default transaction of the calling process is returned.

Description

A precondition for the successful completion of \$GET_DEFAULT_TRANS is that the calling process must have a default transaction.

\$GET_DEFAULT_TRANS may fail for various reasons, including:

- The precondition was not met.
- The default transaction was being changed at the time of the call.

The postcondition on successful completion of \$GET_DEFAULT_TRANS is described in Table 1:

Table 1. Postcondition When \$GET_DEFAULT_TRANS Completes Successfully

Postcondition	Meaning
The identifier of the default transaction of the calling process is returned.	The identifier (TID) of the default transaction of the calling process is returned in the <i>tid</i> argument.

Required Privileges

None

Required Quotas

None

Related Services

\$ABORT_TRANS, \$ABORT_TRANSW, \$ACK_EVENT, \$ADD_BRANCH, \$ADD_BRANCHW, \$CREATE_UID, \$DECLARE_RM, \$DECLARE_RMW, \$END_BRANCH, \$END_BRANCHW, \$END_TRANS, \$END_TRANSW, \$FORGET_RM, \$FORGET_RMW, \$GETDTI, \$GETDTIW, \$JOIN_RM, \$JOIN_RMW, \$SETDTI, \$SETDTIW, \$SET_DEFAULT_TRANS, \$SET_DEFAULT_TRANSW, \$START_BRANCH, \$START_BRANCHW, \$START_TRANS, \$START_TRANSW, \$TRANS_EVENT, \$TRANS_EVENTW

Condition Values Returned

SS\$_NORMAL

The request was successful.

SS\$_INSFARGS

A required argument was missing.

SS\$_INSFMEM

There was insufficient system dynamic memory for the operation.

SS\$_NOCURTID

The calling process did not have a default transaction.

SS\$_WRONGSTATE

The default transaction was being changed at the time of the call.

\$GET_GALAXY_LOCK_INFO (Alpha Only)

Get OpenVMS Galaxy Lock Information — Returns "interesting" fields from the specified lock. Note that this system service is supported only in an OpenVMS Alpha Galaxy environment. For more information about programming with OpenVMS Galaxy system services, refer to the *VSI OpenVMS Alpha Partitioning and Galaxy Guide*.

Format

```
SYS$GET_GALAXY_LOCK_INFO
    handle ,name ,timeout ,size ,ipl ,rank ,flags [,name_length]
```

C Prototype

```
int sys$get_galaxy_lock_info
    (unsigned __int64 lock_handle, char *name, unsigned int *timeout,
     unsigned int *size, unsigned int *ipl, unsigned int *rank,
     unsigned short int *flags unsigned short int *name_length);
```

Arguments

handle

OpenVMS usage: handle for the galaxy lock
type: quadword (unsigned)
access: read
mechanism: input by value

The 64-bit lock handle that identifies the lock on which to return information. This value is returned by `SYSCREATE_GALAXY_LOCK`.

name

OpenVMS usage: address
type: zero-terminated string
access: write
mechanism: output by reference

Pointer to a buffer. This buffer must be large enough to receive the name of the lock. Locks names are zero-terminated strings with a maximum size of 16 bytes.

timeout

OpenVMS usage: address
type: longword (unsigned)
access: write
mechanism: output by reference

Pointer to a longword. The value returned is the timeout value of the lock.

size

OpenVMS usage: address
type: longword (unsigned)
access: write
mechanism: output by reference

Pointer to a longword. The value returned is the size of the lock in bytes.

ipl

OpenVMS usage: address
type: longword (unsigned)
access: write
mechanism: output by reference

Pointer to a longword. The value returned is the IPL of the lock.

rank

OpenVMS usage: address
type: longword (unsigned)

access: write
mechanism: output by reference

Pointer to a longword. The value returned is the rank of the lock.

flags

OpenVMS usage: address
type: word (unsigned)
access: write
mechanism: output by reference

Pointer to a word. The value returned is the word mask of lock flags.

name_length

OpenVMS usage: address
type: word (unsigned)
access: write
mechanism: output by reference

Length of the string returned in the *name* argument.

Description

This service returns all "interesting" fields from the specified lock. See the \$CREATE_GALAXY_LOCK service for detailed information regarding these values.

Required Access or Privileges

Read access to lock.

Required Quota

None

Related Services

\$ACQUIRE_GALAXY_LOCK, \$CREATE_GALAXY_LOCK,
\$CREATE_GALAXY_LOCK_TABLE, \$DELETE_GALAXY_LOCK,
\$DELETE_GALAXY_LOCK_TABLE, \$GET_GALAXY_LOCK_SIZE,
\$RELEASE_GALAXY_LOCK

Condition Values Returned

SS\$_NORMAL

Normal completion.

SS\$_IVLOCKID

Invalid lock id.

SS\$_IVLOCKTBL

Invalid lock table.

\$GET_GALAXY_LOCK_SIZE (Alpha Only)

Get OpenVMS Galaxy Lock Size — Returns the minimum and maximum size of an OpenVMS Galaxy lock. Note that this system service is supported only in an OpenVMS Alpha Galaxy environment. For more information about programming with OpenVMS Galaxy system services, refer to the *VSI OpenVMS Alpha Partitioning and Galaxy Guide*.

Format

```
SY$_GET_GALAXY_LOCK_SIZE min_size ,max_size
```

C Prototype

```
int sys$get_galaxy_lock_size  
    (unsigned int *min_size, unsigned int *max_size);
```

Arguments**min_size**

OpenVMS usage: address
type: longword (unsigned)
access: write
mechanism: output by reference

Pointer to a longword. The value returned is minimum legal size of a galaxy lock structure.

max_size

OpenVMS usage: address
type: longword (unsigned)
access: write
mechanism: output by reference

Pointer to a longword. The value returned is maximum legal size of a galaxy lock structure.

Description

This service returns the minimum and maximum size of an OpenVMS Galaxy lock. If a lock is created with the maximum size, the locking services will record acquire and release information in the lock.

The lock sizes can be used to determine the value of the *section_size* parameter to the `$CREATE_GALAXY_LOCK_TABLE` service.

Required Access or Privileges

Read access to lock.

Required Quota

None

Related Services

\$ACQUIRE_GALAXY_LOCK, \$CREATE_GALAXY_LOCK,
\$CREATE_GALAXY_LOCK_TABLE, \$DELETE_GALAXY_LOCK,
\$DELETE_GALAXY_LOCK_TABLE, \$GET_GALAXY_LOCK_INFO,
\$RELEASE_GALAXY_LOCK

Condition Values Returned

SS\$_NORMAL

Normal completion.

\$GET_REGION_INFO (Alpha and Integrity servers)

Get Information About a Specified Virtual Region — On Alpha and Integrity server systems, gets information about a specified virtual region. This service accepts 64-bit addresses.

Format

```
SYSS$GET_REGION_INFO  
    function_code , region_id_64 , start_va_64 , nullarg , buffer_length  
    , buffer_address_64 , return_length_64
```

C Prototype

```
int sys$get_region_info  
    (unsigned int function_code, struct _generic_64 *region_id_64,  
    void *start_va_64, void *reserved, unsigned int buffer_length,  
    void *buffer_address_64, unsigned int *return_length_64);
```

Arguments

function_code

OpenVMS usage: function code
type: longword (unsigned)
access: read only
mechanism: by value

Function code specifying how the information you are requesting should be looked up. All function codes return region summary information in the return buffer in the format of the Region Summary Buffer. The Region Summary Buffer format is shown in Table 2 in the *buffer_address_64* argument.

If less buffer space is specified than the length of the Region Summary Buffer, only the amount of information requested is returned. If more buffer space is specified than the length of the Region Summary Buffer, the service will fill in the buffer. The return length will reflect the amount of useful information written to the buffer, the size of the Region Summary Buffer.

The file VADEF.H in SYS\$STARLET_C.TLB and the \$VADEF macro in STARLET.MLB define a symbolic name for each function code. The following function codes are defined:

Symbolic Name	Description
VA\$_REGSUM_BY_ID	Return the region summary information for the region whose ID is specified in the <i>region_id_64</i> argument.
VA\$_REGSUM_BY_VA	Return the region summary information for the region that contains the virtual address specified in the <i>start_va_64</i> argument.
VA\$_NEXT_REGSUM_BY_VA	Return the region summary information for the region containing the starting address. If the starting address is not in a region, return the region summary information for the next region with a starting address higher than the specified address. Note: For the VA\$_NEXT_REGSUM_BY_VA function, OpenVMS checks for a <i>start_va_64</i> argument in the inaccessible address range in P2 space. If it finds one, OpenVMS adjusts the address to account for the discontinuity. For more information about the layout of the 64-bit virtual address space, see the <i>VSI OpenVMS Programming Concepts Manual</i> . This function code can be used for wildcard operations. See the description of the <i>start_va_64</i> argument for information on how to program a wildcard operation on regions.

region_id_64

OpenVMS usage: region identifier
 type: quadword (unsigned)
 access: read only
 mechanism: by 32- or 64-bit reference

The region ID associated with the region about which information is requested. This argument is read only if the function code VA\$_REGSUM_BY_ID is specified.

The file VADEF.H in SYS\$STARLET_C.TLB and the \$VADEF macro in STARLET.MLB define a symbolic name for each of the three default regions in P0, P1, and P2 space. The following region IDs are defined:

Symbol	Region
VA\$C_P0	Program region
VA\$C_P1	Control region
VA\$C_P2	64-bit program region

Other region IDs, as returned by the \$CREATE_REGION_64 service, can be specified.

start_va_64

OpenVMS usage: input address
type: quadword address
access: read only
mechanism: by value

Virtual address associated with region about which information is requested. This argument is read only if the *function_code* argument is VA\$_REGSUM_BY_VA or VA\$_NEXT_REGSUM_BY_VA.

If the *function_code* argument is VA\$_REGSUM_BY_VA, this argument is a virtual address within the region about which you are requesting information.

To perform a wildcard search on all regions, specify VA\$_NEXT_REGSUM_BY_VA as the function code and begin with the *start_va_64* argument specified as -1. For subsequent calls, specify *start_va_64* as the sum of the previous region's start address and length. Call the \$GET_REGION_INFO service in a loop until the condition SS\$_NOMOREREG is returned.

Note

Before performing the lookup function, OpenVMS sign-extends the 64-bit starting address so that it represents a properly formed virtual address for the CPU.

nullarg

OpenVMS usage: null_arg
type: longword (unsigned)
access: read only
mechanism: by value

Placelholding argument reserved to OpenVMS.

buffer_length

OpenVMS usage: longword_unsigned
type: longword (unsigned)
access: read only
mechanism: by value

Length of the buffer into which information is returned.

buffer_address_64

OpenVMS usage: varying_arg
type: unspecified
access: write only
mechanism: by 32- or 64-bit reference

The 32- or 64-bit virtual address of a quadword-aligned buffer into which to return information if the *buffer_length* argument is non-zero.

This argument is ignored if the *buffer_length* argument is zero.

Table 2. Region Summary Buffer Format

Field name	Meaning	Field Size (Bytes)	Field Offset (Decimal)
VA\$L_FLAGS	Flags used when region was created	4	8
VA\$L_REGION_PROTECT	Create and owner mode of region	4	12
VA\$Q_REGION_ID	Region identifier	8	0
VA\$PQ_START_VA	Starting (lowest) virtual address of region	8	16
VA\$Q_REGION_SIZE	Total length of region	8	24
VA\$PQ_FIRST_FREE_VA	First free virtual address in region	8	32
VA\$C_REGSUM_LENGTH	Length of Region Summary Buffer	constant	40

The file VADEF.H in SYS\$STARLET_C.TLB and the \$VADEF MACRO in STARLET.MLB define the REGSUM structure.

return_length_64

OpenVMS usage: longword_unsigned
 type: longword (unsigned)
 access: write only
 mechanism: by 32- or 64-bit reference

The 32- or 64-bit virtual address of a naturally aligned longword into which the service returns the length of the information in bytes.

Description

The Get Information About a Specified Virtual Region service is a kernel mode service that can be called from any mode. This service gets the requested information about the specified region or the next region in a wildcard search. If the returned value of this service is not a successful condition value, a value *cannot* be returned in the memory locations pointed to by the *buffer_address_64* or *return_length_64* arguments.

Required Privileges

None

Required Quota

None

Related Services

\$CREATE_REGION_64, \$DELETE_REGION_64

Condition Values Returned

SS\$_NORMAL

The service completed successfully.

SS\$_ACCVIO

The *buffer_address_64* argument or the *return_length_64* argument cannot be written by the caller.

SS\$_BADPARAM

Unrecognized function code.

SS\$_IVREGID

Invalid region ID specified in conjunction with the VA\$_REGSUM_BY_ID function code.

SS\$_NOMOREREG

No region at a higher address than specified in the *start_va_64* argument, which was specified in conjunction with the wildcard function code VA\$_NEXT_REGSUM_BY_VA.

SS\$_PAGNOTINREG

The value specified in the *start_va_64* argument is not within a region and was specified in conjunction with the function code VA\$_REGSUM_BY_VA.

\$GET_SECURITY

Get Security Characteristics — Retrieves the security characteristics of an object.

Format

```
SYS$GET_SECURITY  
    [clsnam] , [objnam] , [objhan] , [flags] , [itmlst] , [contxt] , [acmode]
```

C Prototype

```
int sys$get_security  
    (void *clsnam, void *objnam, unsigned int *objhan, unsigned int flags,  
     void *itmlst, unsigned int *contxt, unsigned int *acmode);
```

Arguments

clsnam

OpenVMS usage: char_string
type: character-coded text string
access: read only
mechanism: by descriptor

Name of the object class. The *clsnam* argument is the address of a descriptor pointing to a string containing the name of the object class. The following is a list of protected object class names:

CAPABILITY
 COMMON_EVENT_CLUSTER
 DEVICE
 FILE
 GLXSYS_GLOBAL_SECTION
 GLXGRP_GLOBAL_SECTION
 GROUP_GLOBAL_SECTION
 ICC_ASSOCIATION
 LOGICAL_NAME_TABLE
 QUEUE
 RESOURCE_DOMAIN
 SECURITY_CLASS
 SYSTEM_GLOBAL_SECTION
 VOLUME

objnam

OpenVMS usage: char_string
 type: character-coded text string
 access: read only
 mechanism: by descriptor

Name of the protected object whose associated security profile is going to be retrieved. The *objnam* argument is the address of a descriptor pointing to a string containing the name of the protected object.

The format of an object name is class specific. The following table lists object names and describes their formats.

Object Class	Object Name Format
CAPABILITY	A character string. Currently, the only capability object is VECTOR.
COMMON_EVENT_CLUSTER	Name of the event flag cluster, as defined in the Associate Common Event Flag Cluster (\$ASCEFC) system service.
DEVICE	Standard device specification, described in the <i>VSI OpenVMS User's Manual</i> .
FILE	Standard file specification, described in the <i>VSI OpenVMS User's Manual</i> .
GROUP_GLOBAL_SECTION	Section name, as defined in the Create and Map Section (\$CRMPSC) system service.
ICC_ASSOCIATION	ICC security object name <i>node::association_name</i> . The special node name, ICC\$:, refers to entries in the clusterwide registry. For registry entries, the Access Access Type does not apply.
LOGICAL_NAME_TABLE	Table name, as defined in the Create Logical Name Table (\$CRELNT) system service.
QUEUE	Standard queue name, as described in the Send to Job Controller (\$SNDJBC) system service.

Object Class	Object Name Format
RESOURCE_DOMAIN	An identifier or octal string enclosed in brackets.
SECURITY_CLASS	Any class name shown in column 1, or a class name followed by a period (.) and the template name. Use the DCL command SHOW SECURITY to display possible template names.
SYSTEM_GLOBAL_SECTION	Section name, as defined in the Create and Map Section (\$CRMPSC) system service.
VOLUME	Volume name or name of the device on which the volume is mounted.

objhan

OpenVMS usage: object_handle
type: longword (unsigned)
access: read only
mechanism: by reference

Data structure identifying the object whose associated characteristics are going to be retrieved. The *objhan* argument is an address of a longword containing the object handle. You can use the *objhan* argument as an alternative to the *objnam* argument; for example, channel number clearly specifies the file open on the channel and can serve as an object handle. The following table shows the format of the object classes.

Object Class	Object Handle Format
COMMON_EVENT_CLUSTER	Event flag number
DEVICE	Channel number
FILE	Channel number
RESOURCE_DOMAIN	Resource domain identifier
VOLUME	Channel number

flags

OpenVMS usage: flags
type: mask_longword
access: read only
mechanism: by value

Mask specifying processing options. The *flags* argument is a longword bit vector wherein a bit, when set, specifies the processing option. The *flags* argument requires the *context* argument. The following table describes each flag.

Symbolic Name	Description
OSS\$M_RELCTX	Release the context structure at the completion of this request.
OSS\$M_WLOCK	Maintain a write lock on the security profile at the completion of this request. \$GET_SECURITY ignores the flag if the context has already been established.

These symbolic names are defined in the \$OSSDEF macro. You construct the *flags* argument by specifying the symbolic names of each flag.

itmlst

OpenVMS usage: item_list_3
 type: longword (unsigned)
 access: read only
 mechanism: by reference

Item list specifying which information about the process or processes is to be returned. The *itmlst* argument is the address of a list of item descriptors, each of which describes an item of information. The list of item descriptors is terminated by a longword of 0.

With the item list, the user retrieves the protected object's characteristics. The user defines which security characteristics to retrieve. If this argument is not present, only the *flags* argument is processed. Without the *itmlst* argument, you can *only* manipulate the security profile lock or release *contxt* resources.

The following diagram depicts a single item descriptor.

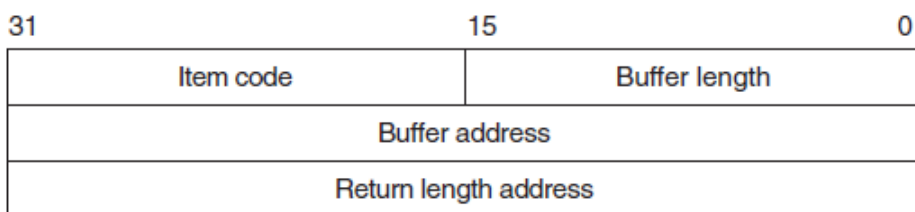

ZK-5186A-GE

The following table describes the item descriptor fields.

Descriptor Field	Definition
Buffer length	A word containing an integer specifying the length (in bytes) of the buffer in which \$GET_SECURITY is to write the information. The length of the buffer needed depends on the item code specified in the item code field of the item descriptor. If the value of buffer length is too small, \$GET_SECURITY truncates the data.
Item code	A word containing a symbolic code specifying the item of information that \$GET_SECURITY is to return. The \$OSSDEF macro defines these codes. A description of each item code is given in the Item Codes section.
Buffer address	A longword containing the address of the buffer in which \$GET_SECURITY is to write the information.
Return length address	A longword containing the address of a word in which \$GET_SECURITY writes the length (in bytes) of the information it actually returns.

contxt

OpenVMS usage: context
 type: longword (unsigned)
 access: modify
 mechanism: by reference

Value used to maintain the processing context when dealing with a single protected object across multiple \$GET_SECURITY/\$SET_SECURITY calls. Whenever the context value is nonzero, the class name, object name, or object handle arguments are disregarded. An input value of 0 indicates that a new context should be established.

Because an active context block consumes process memory, be sure to release the context block by setting the RELCTX flag when the profile processing is complete. \$GET_SECURITY sets the context argument to 0 once the context is released.

acmode

OpenVMS usage: access_mode
 type: longword (unsigned)
 access: read only
 mechanism: by reference

Access mode to be used in the object protection check. The *acmode* argument is the address of a longword containing the access mode. The *acmode* argument defaults to kernel mode; however, the system compares *acmode* with the caller's access mode and uses the least privileged mode. The access modes are defined in the system macro \$PSLDEF library. VSI recommends that this argument be omitted (passed as zero).

Item Codes

The following table provides a summary of item codes that are valid in an item descriptor in the *itmlst* argument. Complete descriptions of each item code are provided after the table.

Item Identifier	Description
OSS\$_ACCESS_NAMES	Returns access bitname translation table for the class.
OSS\$_ACCESS_NAMES_LENGTH	Returns the size (in bytes) of the access bitname translation table.
OSS\$_ACL_FIND_ENTRY	Locates an access control entry (ACE).
OSS\$_ACL_FIND_NEXT	Positions to the next ACE.
OSS\$_ACL_FIND_TYPE	Locates an ACE of specified type.
OSS\$_ACL_GRANT_ACE	Locates an ACE that either grants or denies access.
OSS\$_ACL_LENGTH	Returns the length of the access control list (ACL).
OSS\$_ACL_POSITION_BOTTOM	Sets a marker that points to the end of the ACL.
OSS\$_ACL_POSITION_TOP	Sets a marker that points to the beginning of the ACL.
OSS\$_ACL_READ	Reads the entire ACL.
OSS\$_ACL_READ_ENTRY	Reads an ACE.
OSS\$_CLASS_NAME	Returns the full object class name.
OSS\$_FIRST_TEMPLATE	Returns the name of the first template profile of a Security_Class object.
OSS\$_NEXT_OBJECT	Returns the name of the next Security_Class object.
OSS\$_NEXT_TEMPLATE	Returns the name of the next template profile of a Security_Class object.

Item Identifier	Description
OSS\$_OBJECT_NAME	Returns the name of the object. The FILE class does not return an object name.
OSS\$_OWNER	Returns the UIC or general identifier of the object's owner.
OSS\$_PROTECTION	Returns the protection code of the object.

OSS\$_ACCESS_NAMES

When you specify OSS\$_ACCESS_NAMES, \$GET_SECURITY returns the access name translation table in the buffer pointed to by the buffer address field of the item descriptor.

The access name translation table is a 32-quadword vector followed by a variable section containing the access names. Each bit in the vector represents a single access type. The contents of the quadword is a string descriptor that corresponds to the ASCII bitname string. Undefined access types have zero-length names. The return length, if present, returns the length of the table.

OSS\$_ACCESS_NAMES_LENGTH

When you specify OSS\$_ACCESS_NAMES_LENGTH, \$GET_SECURITY returns the length of the access name translation table.

OSS\$_ACL_FIND_ENTRY

When you specify OSS\$_ACL_FIND_ENTRY, \$GET_SECURITY locates an ACE pointed to by the buffer address. OSS\$_ACL_FIND_ENTRY sets the position within the ACL for succeeding ACL operations; for example, for a deletion or modification of the ACE. If the buffer address is 0, it returns SS\$_ACCVIO.

OSS\$_ACL_FIND_NEXT

When you specify OSS\$_ACL_FIND_NEXT, \$GET_SECURITY advances the current position to the next ACE in the ACL.

OSS\$_ACL_FIND_TYPE

When you specify OSS\$_ACL_FIND_TYPE, \$GET_SECURITY returns an ACE of a particular type if there is one in the buffer pointed to by the buffer address. OSS\$_ACL_FIND_TYPE sets the position within the ACL for succeeding ACL operations. If the buffer address is 0, it returns SS\$_ACCVIO.

OSS\$_ACL_GRANT_ACE

When you specify OSS\$_ACL_GRANT_ACE, \$GET_SECURITY returns the ACE in the object's ACL that grants or denies the user access to that object. OSS\$_ACL_GRANT_ACE returns the ACE found in the buffer pointed to by the buffer address.

OSS\$_ACL_LENGTH

When you specify OSS\$_ACL_LENGTH, \$GET_SECURITY returns the size (in bytes) of the object's ACL. The buffer address field points to a longword that receives the size.

OSS\$_ACL_POSITION_BOTTOM

When you specify OSS\$_ACL_POSITION_BOTTOM, \$GET_SECURITY sets the ACL position to point to the bottom of the ACL.

OSS\$_ACL_POSITION_TOP

When you specify `OSS$_ACL_POSITION_TOP`, `$GET_SECURITY` sets the ACL position to point to the top of the ACL.

OSS\$_ACL_READ

When you specify `OSS$_ACL_READ`, `$GET_SECURITY` returns the portion of the object's ACL to the buffer pointed to by the buffer address.

OSS\$_ACL_READ_ENTRY

When you specify `OSS$_ACL_READ_ENTRY`, `$GET_SECURITY` reads the ACE pointed to by the buffer address.

OSS\$_CLASS_NAME

When you specify `OSS$_CLASS_NAME`, `$GET_SECURITY` returns the full object class name.

OSS\$_FIRST_TEMPLATE

When you specify `OSS$_FIRST_TEMPLATE`, `$GET_SECURITY` returns the name of the first template profile for the object named in the `objnam` argument. This item code is valid only for security class objects. If the `clsnam` is not `Security_Class`, `SS$_INVCLSITM` is returned.

OSS\$_NEXT_OBJECT

When you specify `OSS$_NEXT_OBJECT`, `$GET_SECURITY` returns the name of the next object. A return length of 0 indicates the end of the list. This item code is valid only for security class objects. If the `clsnam` is not `Security_Class`, `SS$_INVCLSITM` is returned.

OSS\$_NEXT_TEMPLATE

When you specify `OSS$_NEXT_TEMPLATE`, `$GET_SECURITY` returns the name of the next template. This item code allows you to step through a list of an object's templates. A return length of 0 indicates the end of the list. This item code is valid only for security class objects. If the `clsnam` is not `Security_Class`, `SS$_INVCLSITM` is returned.

OSS\$_OBJECT_NAME

When you specify `OSS$_OBJECT_NAME`, `$GET_SECURITY` returns the name of the object.

OSS\$_OWNER

When you specify `OSS$_OWNER`, `$GET_SECURITY` returns the owner of the object.

OSS\$_PROTECTION

When you specify `OSS$_PROTECTION`, `$GET_SECURITY` returns the protection code of the object.

Description

The Get Security service returns information about security characteristics of a selected object. Security characteristics include such information as the protection code, the owner, and the access control list (ACL). The security management services, `$GET_SECURITY` and `$SET_SECURITY`, maintain a single master copy of a profile for every security object in an OpenVMS Cluster environment. They also ensure that only one process at a time can modify an object's security profile.

There are different ways of identifying which protected object `$GET_SECURITY` should process:

- Whenever the `ctxt` argument has a nonzero value, `$GET_SECURITY` uses the context to select the object and ignores the class name, object name, and object handle.
- With some types of objects, such as a file or a device, it is possible to select an object on the basis of its `objhan` and `clsnam` values.
- If neither a nonzero `ctxt` argument nor an `objhan` argument is provided, `$GET_SECURITY` uses an object's class name (`clsnam`) and object name (`objnam`) to select the object.

When you call `$GET_SECURITY`, the service selects the specified protected object and fetches a local copy of the object's security profile.

The context for a security management operation can be established through either `$GET_SECURITY` or `$SET_SECURITY`. Whenever the context is set by one service, the other service can use it, provided the necessary locks are being held. If you intend to modify the profile, you must set the write lock flag (`OSS$M_WLOCK`) when you establish the context.

There are many situations in which the `ctxt` argument is essential. By establishing a context for an ACL operation, for example, a caller can retain an ACL position across calls to `$GET_SECURITY` so that a set of ACEs can be read and modified sequentially. A security context is released by a call to `$SET_SECURITY` or `$GET_SECURITY` that sets the `OSS$M_RELCTX` flag. Once the context is released, the user-supplied context longword is set to 0.

Required Access or Privileges

Read or control access to the object is required.

Required Quota

None

Related Services

`$SET_SECURITY`

Condition Values Returned

`SS$_NORMAL`

The service completed successfully.

`SS$_ACCVIO`

The parameter cannot be read and the buffer cannot be written.

`SS$_BADPARAM`

You specified an invalid object, attribute code, or item size.

`SS$_INSFARG`

The `clsnam` and `objnam` arguments are not specified, the `clsnam` and `objhan` arguments are not specified, or the `ctxt` argument is not specified.

SS\$_INVCLSITM

The item code that you specified is not supported for the class.

SS\$_NOCLASS

The named security class does not exist.

SS\$_OBJLOCKED

The selected object is currently write locked.

\$GET_SYS_ALIGN_FAULT_DATA (Alpha and Integrity servers)

Get System Alignment Fault Data — On Alpha and Integrity server systems, obtains data from the system alignment fault buffer if buffered system alignment fault data reporting has been enabled. This service accepts 64-bit addresses.

Format

```
SYS$GET_SYS_ALIGN_FAULT_DATA buffer ,buffer_size ,return_size
```

C Prototype

```
int sys$get_sys_align_fault_data  
    (void *buffer, int buffer_size, int *return_size);
```

Arguments

buffer

OpenVMS usage: address
type: longword (unsigned)
access: read/write
mechanism: by 32- or 64-bit reference

The user buffer in which the alignment fault data is to be stored. The *buffer* argument is the 32- or 64-bit virtual address of this buffer.

buffer_size

OpenVMS usage: byte count
type: longword (signed)
access: read
mechanism: by value

The size, in bytes, of the buffer specified by the *buffer* argument.

return_size

OpenVMS usage: longword_signed
type: longword (signed)
access: write
mechanism: by 32- or 64-bit reference

The amount of data, in bytes, stored in the buffer. The *return_size* argument is the 32- or 64-bit virtual address of a naturally aligned longword into which the service returns the amount of data, in bytes, stored in the buffer. The *return_size* argument is set to 0 if there is no data in the buffer.

Description

The Get System Alignment Fault Data service obtains data from the system alignment fault buffer if buffered system alignment fault data reporting has been enabled.

When buffered system alignment fault data reporting is enabled, the operating system writes each alignment fault into a system-allocated buffer. The user must poll this buffer periodically to read the data.

The user must call the \$INIT_SYS_ALIGN_FAULT_REPORT service to enable buffered system alignment fault data reporting. For more information, see the \$INIT_SYS_ALIGN_FAULT_REPORT service.

Required Access or Privileges

CMKRNL privilege is required.

Required Quota

None

Related Services

\$GET_ALIGN_FAULT_DATA, \$INIT_SYS_ALIGN_FAULT_REPORT,
\$PERM_DIS_ALIGN_FAULT_REPORT, \$PERM_REPORT_ALIGN_FAULT,
\$START_ALIGN_FAULT_REPORT, \$STOP_ALIGN_FAULT_REPORT,
\$STOP_SYS_ALIGN_FAULT_REPORT

Condition Values Returned

SS\$_NORMAL

The service completed successfully.

SS\$_ACCVIO

The buffer named in the *buffer* argument is not accessible.

SS\$_AFR_NOT_ENABLED

Alignment fault reporting has not been enabled.

SS\$_BADPARAM

The buffer size is smaller than the minimum defined by the AFR\$K_VMS_LENGTH or the AFR\$K_EXTENDED_LENGTH symbol.

\$GET_UNWIND_ENTRY_INFO (Integrity servers Only)

Get Unwind Entry Info Routine — Gets fixed-up unwind entry information.

Format

```
SYSS$GET_UNWIND_ENTRY_INFO pc, get_ue_block, name
```

C Prototype

```
int SYSS$GET_UNWIND_ENTRY_INFO  
    (unsigned __int64 pc, void *get_ue_block, void *name);
```

Arguments

pc

OpenVMS usage: PC value
type: quadword (unsigned)
access: read only
mechanism: by value

Input quadword, target PC (that is, the PC for a code region the user wants unwind information for).

get_ue_block

OpenVMS usage: unwind_entry_data_block
type: quadword (unsigned)
access: write
mechanism: by reference

Address of a 4-quadword block to be filled in. That is, input the address of a 4 quadword block and, on successful returned status, that block will be updated with the following information:

- **code_start_va** - Output quadword, the process virtual starting c unwind region containing the input IP.
- **code_end_va** - Output quadword, the process virtual ending code address of the unwind region containing the input IP.
- **uib_start_va** - Output quadword, the process virtual address of the UIB for the unwind region containing the input IP.
- **gp_value** - Output quadword, the GP value for this code region.

name

OpenVMS usage: pseudo-image-name

type: character-code-text-string
access: modify
mechanism: by descriptor-fixed-length string descriptor

Optional, that is, may be zero. If the name parameter is specified and if a name was registered for the unwind region, then the descriptor pointer and length are updated to point to that stored name. Note that if the name parameter is specified but no name exists in the unwind tables, then the name descriptor is updated to zero length.

Description

Get *fixed up* unwind entry information relevant to the input instruction pointer (IP).

Required Access or Privileges

None

Required Quota

None

Related Services

SYSS\$SET_UNWIND_TABLE, SYSS\$CLEAR_UNWIND_TABLE. Also see LIB\$GET_UIB_INFO in *VSI OpenVMS Calling Standard*.

Condition Values Returned

SS\$_NORMAL

Routine completed successfully.

SS\$_IVADDR

Invalid PC.

SS\$_NODATA

No unwind information found.

\$GET_USER_CAPABILITY (Alpha and Integrity servers)

Reserve a User Capability — On Alpha and Integrity server systems, reserves a user capability, indicating to other processes that the resource is in use. This service accepts 64-bit addresses.

Format

```
SYSS$GET_USER_CAPABILITY  
    cap_num [,select_num] [,select_mask] [,prev_mask] [,flags]
```

C Prototype

```
int sys$get_user_capability
(*cap_num, int *select_num, struct _generic_64 *select_mask,
 struct _generic_64 *prev_mask, struct _generic_64 *flags);
```

Arguments

cap_num

OpenVMS usage: longword
type: longword (unsigned)
access: read only
mechanism: by 32- or 64-bit reference

Capability number to be reserved by the calling kernel thread. This number can range from 1 to 16 for an explicit request, or the symbolic constant `CAP$K_GET_FREE_CAP` can be specified to get the next available user capability. The `cap_num` argument is the 32- or 64-bit address of the longword containing the user capability number or symbolic constant.

select_num

OpenVMS usage: longword
type: longword (unsigned)
access: write only
mechanism: by 32- or 64-bit reference

The number of the user capability selected by the service call. The `select_num` argument is the 32- or 64-bit address of a longword into which the system writes the user capability number. For an explicit numeric request, the value returned in this longword will match that specified in `cap_num`; otherwise, this cell contains the next available user capability.

select_mask

OpenVMS usage: mask_quadword
type: quadword (unsigned)
access: write only
mechanism: by 32- or 64-bit reference

A quadword bit mask with a single bit position set, reflecting the user capability selected by the service. The `select_mask` argument is the 32- or 64-bit address of a quadword into which the system writes the selected user capability bit mask. This bit mask is the most efficient method for indicating the reserved user capability with the `$CPU_CAPABILITIES` and `$PROCESS_CAPABILITIES` services.

prev_mask

OpenVMS usage: mask_quadword
type: quadword (unsigned)
access: write only

mechanism: by 32- or 64-bit reference

The previous user capability reservation mask before execution of this service call. The *prev_mask* argument is the 32- or 64-bit address of a quadword into which the service writes a quadword bit mask specifying the previously reserved user capabilities taken from the global cell SCH\$GQ_RESERVED_USER_CAPS.

flags

OpenVMS usage: mask_quadword
type: quadword (unsigned)
access: read only
mechanism: by 32- or 64-bit reference

Options selected for the user capability reservation. The *flags* argument is a quadword bit vector wherein a bit corresponds to an option.

Each option (bit) has a symbolic name, which the \$CAPDEF macro defines. The *flags* argument is constructed by performing a logical OR operation using the symbolic names of each desired option.

At this time, all bits are reserved to OpenVMS and must be 0.

Description

The Reserve a User Capability service provides a way for discrete processes to communicate and synchronize their use of a user capability in the system. This service uses the global cell SCH\$GQ_RESERVED_USER_CAPS to indicate that a particular user capability has been reserved. \$GET_USER_CAPABILITY can also return the current reservation state of all user capabilities in the system.

Reservation of a user capability can be made for an explicit number or for the next available number. The selected user capability is returned to the caller through a numeric value in *select_num* or by a quadword bit mask in *select_mask*.

This service does not directly enforce unique use of the individual user capabilities; it simply provides a common informational and control resource for processes using the other capability scheduling services. Code threads that do not use this service to verify whether a user capability is available are still at risk if differing usages conflict.

Required Privileges

The caller must have both ALTPRI and WORLD privileges to call \$GET_USER_CAPABILITY to reserve a user capability. No privileges are required if \$GET_USER_CAPABILITY is called only to retrieve the current user capability reservation mask.

Required Quota

None

Related Services

\$FREE_USER_CAPABILITY, \$CPU_CAPABILITIES, \$PROCESS_CAPABILITIES

Condition Values Returned

SS\$_NORMAL

The service completed successfully.

SS\$_ACCVIO

The service cannot access the locations specified by one or more arguments.

SS\$_INSFARG

Fewer than the required number of arguments were specified, or no operation was specified.

SS\$_NOPRIV

Insufficient privilege for the attempted operation.

SS\$_NOSUCH_OBJECT

No more user capabilities are available.

SS\$_OBJECT_EXISTS

A specifically requested user capability has already been reserved.

SS\$_TOO_MANY_ARGS

Too many arguments were presented to the system service.

\$GOTO_UNWIND (Alpha Only)

Unwind Call Stack — On Alpha systems, unwinds the call stack. On Integrity server systems, do not use this service; use \$GOTO_UNWIND_64 instead.

Format

```
SYS$GOTO_UNWIND target_invo ,target_pc ,[new_r0] ,[new_r1]
```

C Prototype

```
int sys$goto_unwind
(void *target_invo, void *(*(target_pc)), unsigned __int64 *new_r0,
 unsigned __int64 *new_r1);
```

Arguments

target_invo

OpenVMS usage: invo_handle
type: longword (unsigned)
access: read only

mechanism: by reference

The address of a location that contains a handle for the target invocation.

If you do not specify the *target_invo* argument, or if the handle value is 0, an exit unwind is initiated.

target_pc

OpenVMS usage: address
type: longword (unsigned)
access: read only
mechanism: by reference

The address of a location that contains the address at which execution should continue in the target invocation.

If the *target_pc* argument is omitted or the value is 0, a system-defined target PC is assumed and execution resumes at the location specified at the return address for the call frame of the target procedure invocation.

new_r0

OpenVMS usage: quadword_unsigned
type: quadword (unsigned)
access: read only
mechanism: by reference

The address of a location that contains the value to place in the saved R0 location of the mechanism argument vector. The contents of this location are then loaded into the processor R0 register at the time that execution continues in the target invocation.

If the *new_r0* argument is omitted, the contents of the processor R0 register at the time of the call to `$GOTO_UNWIND` are used.

new_r1

OpenVMS usage: quadword_unsigned
type: quadword (unsigned)
access: read only
mechanism: by reference

Address of a location that contains the value to place in the saved R1 location of the mechanism argument vector. The contents of the location are then loaded into the processor R1 register at the time that execution continues in the target invocation.

If the *new_r1* argument is omitted, the contents of the processor R1 register at the time of the call to `$GOTO_UNWIND` are used.

Description

The Unwind Call Stack service provides the function for a procedure to unwind the call stack.

Required Access or Privileges

None

Required Quota

None

Related Services

\$UNWIND

Condition Values Returned

SS\$_NORMAL

The service completed successfully.

SS\$_ACCVIO

The specified *target_invo*, *target_pc*, *new_r0*, or *new_r1* argument is not accessible.

\$GOTO_UNWIND_64 (Alpha and Integrity servers)

Unwind Call Stack — On Alpha and Integrity server systems, unwinds the call stack.

Format

```
SYSGOTO_UNWIND target_invo ,target_pc , [NewRetVal] , [NewRetVal2]
```

C Prototype

```
int sys$goto_unwind_64
(void *target_invo_64, void *(*(target_pc_64)),
 unsigned_int64 *new_retval, unsigned_int64 *newretval2);
```

Arguments

target_invo

OpenVMS usage: *invo_handle*
type: quadword (unsigned)
access: read only
mechanism: by reference

The address of a location that contains a handle for the target invocation.

If you do not specify the *target_invo* argument, or if the handle value is 0, the effect of the call is undefined.

target_pc

OpenVMS usage: address
type: quadword (unsigned)
access: read only
mechanism: by reference

The address of a location that contains the address at which execution should continue in the target invocation.

If the *target_pc* argument is omitted or the value is 0, execution resumes at the location specified at the return address for the call frame of the target procedure invocation.

If the *target_invo* argument is omitted or the value is 0, the *target_pc* argument is ignored. In this case, a system-defined target PC is assumed.

NewRetVal

OpenVMS usage: quadword_unsigned
type: quadword (unsigned)
access: read only
mechanism: by reference

The address of a location that contains the value to place in the saved RetVal location of the mechanism argument vector. The contents of this location are then loaded into RetVal at the time that execution continues in the target invocation.

If the *NewRetVal* argument is omitted, the contents of RetVal at the time of the call to \$GOTO_UNWIND_64 are used.

This argument is called *New_R0* in SYSSGOTO_UNWIND for compatibility with Alpha.

NewRet2

OpenVMS usage: quadword_unsigned
type: quadword (unsigned)
access: read only
mechanism: by reference

The address of a location that contains the value to place in the saved RetVal2 location of the mechanism argument vector. The contents of the location are then loaded into RetVal2 at the time that execution continues in the target invocation.

If the *NewRet2* argument is omitted, the contents of RetVal2 at the time of the call to \$GOTO_UNWIND_64 are used.

This argument is called *New_R1* in SYSSGOTO_UNWIND for compatibility with Alpha.

Description

The Unwind Call Stack service provides the function for a procedure to unwind the call stack.

Required Access or Privileges

None

Required Quota

None

Related Services

\$UNWIND

Condition Values Returned

SS\$_ACCVIO

An invalid address was given.

\$GRANTID

Grant Identifier to Process — Adds the specified identifier record to the rights list of the process or the system.

Format

```
SYS$GRANTID [pidadr] , [prcnam] , [id] , [name] , [prvatr]
```

C Prototype

```
int sys$grantid
(unsigned int *pidadr, void *prcnam, struct _generic_64 *id, void *name,
 unsigned int *prvatr, unsigned int segment);
```

Arguments

pidadr

OpenVMS usage: process_id
type: longword (unsigned)
access: modify
mechanism: by reference

Process identification (PID) number of the process affected when \$GRANTID completes execution. The *pidadr* argument is the address of a longword containing the PID of the process to be affected. You use `-1` to indicate the system rights list. When *pidadr* is passed, it is also returned; therefore, you must pass it as a variable rather than a constant. If you specify neither *pidadr* nor *prcnam*, your own process is used.

prcnam

OpenVMS usage: process_name
 type: character-coded text string
 access: read only
 mechanism: by descriptor–fixed-length string descriptor

Process name on which \$GRANTID operates. The *prcnam* argument is the address of a character string descriptor containing the process name. The maximum length of the name is 15 characters. Because the UIC group number is interpreted as part of the process name, you must use *pidadr* to specify the rights list of a process in a different group. If you specify neither *pidadr* nor *prcnam*, your own process is used.

id

OpenVMS usage: rights_holder
 type: quadword (unsigned)
 access: modify
 mechanism: by reference

Identifier and attributes to be granted when \$GRANTID completes execution. The *id* argument is the address of a quadword containing the binary identifier code to be granted in the first longword and the attributes in the second longword.

Use the *id* argument to modify the attributes of the identifier.

Symbol values are offsets to the bits within the longword. You can also obtain the values as masks with the appropriate bit set using the prefix KGB\$M rather than KGB\$V. The following symbols for each bit position are defined in the macro library (\$KGBDEF).

Bit Position	Meaning When Set
KGB\$V_DYNAMIC	Allows holders of the identifier to remove it from or add it to the process rights database using the DCL command SET RIGHTS_LIST.
KGB\$V_NOACCESS	Makes any access rights of the identifier null and void. This attribute is intended as a modifier for a resource identifier or the Subsystem attribute.
KGB\$V_RESOURCE	Allows holders of an identifier to charge disk space to the identifier. It is used only for file objects.
KGB\$V_SUBSYSTEM	Allows holders of the identifier to create and maintain protected subsystems by assigning the Subsystem ACE to the application images in the subsystem.

You must specify either *id* or *name*. Because the *id* argument is returned as well as passed if you specify *name*, you must pass it as a variable rather than a constant in this case.

name

OpenVMS usage: char_string
 type: character-coded text string
 access: read only
 mechanism: by descriptor–fixed-length string descriptor

Name of the identifier granted when \$GRANTID completes execution. The *name* argument is the address of a descriptor pointing to the name of the identifier. The identifier is granted as it is created. You must specify either *id* or *name*.

prvatr

OpenVMS usage: mask_longword
 type: longword (unsigned)
 access: write only
 mechanism: by reference

Previous attributes of the identifier. The *prvatr* argument is the address of a longword used to store the attributes of the identifier if it was previously present in the rights list. If you added rather than modified the identifier, *prvatr* is ignored.

Description

The Grant Identifier to Process service adds the specified identifier to the rights list of the process or the system. If the identifier is already in the rights list, its attributes are modified to those specified. This service is meant to be used by a privileged subsystem to alter the access rights profile of a user, based on installation policy. It is not meant to be used by the general system user.

The result of passing the *pidadr* or the *prcnam* argument, or both, to SYS\$GRANTID is summarized in the following table.

prcnam	pidadr	Result
Omitted	Omitted	Current process ID is used; process ID is not returned.
Omitted	0	Current process ID is used; process ID is returned.
Omitted	Specified	Specified process ID is used.
Specified	Omitted	Specified process name is used; process ID is not returned.
Specified	0	Specified process name is used; process ID is returned.
Specified	Specified	Specified process ID is used and process name is ignored.

The result of passing the *name* or the *id* argument, or both, to SYS\$GRANTID is summarized in the following table.

name	id	Result
Omitted	Omitted	Illegal. The INSFARG condition value is returned.
Omitted	Specified	Specified identifier value is used.
Specified	Omitted	Specified identifier name is used; identifier value is not returned.
Specified	0	Specified identifier name is used; identifier value is returned.
Specified	Specified	Specified identifier value is used and identifier name is ignored.

Note that a value of 0 in either of the preceding tables indicates that the contents of the address specified by the argument is the value 0. The word *omitted* indicates that the argument was not supplied.

Required Access or Privileges

You need CMKRNL privilege to invoke this service. In addition, you need GROUP privilege to modify the rights list of a process in the same group as the calling process (unless the process has the same UIC as the calling process). You need WORLD privilege to modify the rights list of a process outside the caller's group. You need SYSNAM privilege to modify the system rights list.

Required Quota

None

Related Services

\$ADD HOLDER, \$ADD_IDENT, \$ASCTOID, \$CHECK_ACCESS, \$CHKPRO, \$CREATE_RDB, \$ERAPAT, \$FIND_HELD, \$FIND HOLDER, \$FINISH_RDB, \$FORMAT_ACL, \$FORMAT_AUDIT, \$GET_SECURITY, \$HASH_PASSWORD, \$IDTOASC, \$MOD HOLDER, \$MOD_IDENT, \$MTACCESS, \$PARSE_ACL, \$REM HOLDER, \$REM_IDENT, \$REVOKID, \$SET_SECURITY

Condition Values Returned

SS\$_WASCLR

The service completed successfully; the rights list did not contain the specified identifier.

SS\$_WASSET

The service completed successfully; the rights list already held the specified identifier.

SS\$_ACCVIO

The *pidadr* argument cannot be read or written; *prcnam* cannot be read; *id* cannot be read or written; the *name* cannot be read; or *prvatr* cannot be written.

SS\$_INSFARG

You did not specify either the *id* or the *name* argument.

SS\$_INSFMEM

The process dynamic memory is insufficient for opening the rights database.

SS\$_IIDENT

The specified identifier name is invalid; the identifier name is longer than 31 characters, contains an illegal character, or does not contain at least one nonnumeric character.

SS\$_IVLOGNAM

You specified an invalid process name.

SS\$_NONEXPR

You specified a nonexistent process.

SS\$_NOPRIV

The caller does not have CMKRNL privilege or is not running in executive or kernel mode, or the caller lacks GROUP, WORLD, or SYSNAM privilege as required.

SS\$_NOSUCHID

The specified identifier name does not exist in the rights database. Note that the binary identifier, if given, is not validated against the rights database.

SS\$_NOSYSNAM

The operation requires SYSNAM privilege.

SS\$_RIGHTSFULL

The rights list of the process or system is full.

RMS\$_PRV

The user does not have read access to the rights database.

Because the rights database is an indexed file accessed with OpenVMS RMS, this service can also return RMS status codes associated with operations on indexed files. For descriptions of these status codes, refer to the *VSI OpenVMS Record Management Services Reference Manual*.

\$HASH_PASSWORD

Hash Password — Applies the hash algorithm you select to an ASCII password string and returns a quadword hash value that represents the encrypted password.

Format

```
SY$_HASH_PASSWORD pwd ,alg , [salt] ,usrnam ,hash
```

C Prototype

```
int sys$hash_password  
    (void *pwd, unsigned char alg, unsigned short int salt, void *usrnam,  
     struct _generic_64 *hash);
```

Arguments

pwd

OpenVMS usage: char_string
type: character-coded text string
access: read only
mechanism: by descriptor – fixed-length string descriptor

ASCII password string to be encrypted. The *pwd* argument is the address of a character string descriptor pointing to the ASCII password. The password string can contain between 1 and 32 characters and use

the uppercase characters A through Z, the numbers 0 through 9, the dollar sign (\$), and the underscore (_).

The caller must validate the password string before calling \$HASH_PASSWORD to ensure that only permitted characters are included.

alg

OpenVMS usage: byte_unsigned
 type: byte (unsigned)
 access: read only
 mechanism: by value

Algorithm used to hash the ASCII password string. The *alg* argument is an unsigned byte specifying the hash algorithm.

The operating system recognizes the following algorithms.

Symbolic Name	Description
UAI\$K_AD_II	Uses a CRC algorithm and returns a longword hash value. This algorithm was used in releases prior to VAX/VMS Version 2.0.
UAI\$C_PURDY	Uses a Purdy algorithm over salted input. It expects a blank-padded user name and returns a quadword hash value. This algorithm was used during VAX/VMS Version 2.0 field test.
UAI\$C_PURDY_V	Uses the Purdy algorithm over salted input. It expects a variable-length user name and returns a quadword hash value. This algorithm was used in releases prior to VMS Version 5.4.
UAI\$K_PURDY_S	Uses the Purdy algorithm over salted input. It expects a variable-length user name and returns a quadword hash value. This algorithm is used to hash all new passwords in VMS Version 5.4 and later.
UAI\$C_PREFERRED_ALGORITHM ¹	Represents the latest encryption algorithm that the operating system uses to encrypt new passwords. Currently, it equates to UAI\$C_PURDY_S. VSI recommends that you use this symbol in source modules because it always equates with the most recent algorithm.

¹The value of this symbol might be changed in future releases if an additional algorithm is introduced.

Values ranging from 128 to 255 are reserved for customer use; the constant UAI\$K_CUST_ALGORITHM defines the start of this range.

You can use the UAI\$_ENCRYPT and UAI\$_ENCRYPT2 item codes with the \$GETUAI system service to retrieve the primary and secondary password hash algorithms for a user.

salt

OpenVMS usage: word_unsigned
 type: word (unsigned)

access: read only
mechanism: by value

Value used to increase the effectiveness of the hash. The *salt* argument is an unsigned word containing 16 bits of data that is used by the hash algorithms when encrypting a password for the associated user name. The \$GETUAI item code UAI\$_SALT is used to retrieve the SALT value for a given user. If you do not specify a SALT value, \$HASH_PASSWORD uses the value of 0.

usrnam

OpenVMS usage: char_string
type: character-coded text string
access: read only
mechanism: by descriptor – fixed-length string descriptor

Name of the user associated with the password. The *usrnam* argument is the address of a descriptor pointing to a character text string containing the user name. The current password encryption algorithm (UAI\$_PURDY_S) folds the user name into the ASCII password string to ensure that different users with the same password produce different hash values. This argument must be supplied for all calls to \$HASH_PASSWORD but is ignored when using the CRC algorithm (UAI\$_AD_II).

hash

OpenVMS usage: quadword_unsigned
type: quadword (unsigned)
access: write only
mechanism: by reference

Output hash value representing the encrypted password. The *hash* argument is the address of an unsigned quadword to which \$HASH_PASSWORD writes the output of the hash. If you use the UAI\$_AD_II algorithm, the second longword of the hash is always set to 0.

Description

The Hash Password service applies the hash algorithm you select to an ASCII password string and returns a quadword hash value that represents the encrypted password.

Other OpenVMS password services allow spaces, tabs, and other blank characters from the user, but they remove those spaces before passing the string to \$HASH_PASSWORD. Before calling \$HASH_PASSWORD, all white space must be removed from the password string to ensure proper comparison with passwords created by other services.

Required Access or Privileges

None

Required Quota

None

Related Services

\$GETUAI, \$SETUAI.

Use \$GETUAI to get the values for the *salt* and *alg* arguments. Use \$SETUAI to store the resulting hash using the item codes UAI\$_PWD and UAI\$_PWD2.

For more information, see the appendix on implementing site-specific security policies in the *VSI OpenVMS Programming Concepts Manual*.

Condition Values Returned

SS\$_NORMAL

The service completed successfully.

SS\$_ACCVIO

The input or output buffer descriptors cannot be read or written to by the caller.

SS\$_BADPARAM

The specified hash algorithm is unknown or invalid.

\$HIBER

Hibernate — Allows a process to make itself inactive but to remain known to the system so that it can be interrupted; for example, to receive ASTs.

Format

SYS\$HIBER

C Prototype

```
int sys$hiber (void);
```

Arguments

None.

Description

The Hibernate service allows a process to make itself inactive but to remain known to the system so that it can be interrupted; for example, to receive ASTs. A hibernate request is a wait-for-wake-event request. When you call the Wake Process from Hibernation (\$WAKE) service or when the time specified with the Schedule Wakeup (\$SCHDWK) service occurs, the process continues execution at the instruction following the Hibernate call.

In VAX MACRO, you can call the Hibernate service only by using the \$name_S macro.

A hibernating process can be swapped out of the balance set if it is not locked into the balance set.

An AST can interrupt the wait state caused by \$HIBER if the access mode at which the AST is to execute is equal to or more privileged than the access mode from which the hibernate request was issued and the process is enabled for ASTs at that access mode.

When the AST service routine completes execution, the system reexecutes the \$HIBER service on behalf of the process. If a wakeup request has been issued for the process during the execution of the AST service routine (either by itself or another process), the process resumes execution. If a wakeup request has not been issued, it continues to hibernate.

If one or more wakeup requests are issued for the process while it is not hibernating, the next hibernate call returns immediately; that is, the process does not hibernate. No count of outstanding wakeup requests is maintained.

Although this service has no arguments, a Fortran function reference must use parentheses to indicate a null argument list, as in the following example:

```
ISTAT=SYS$HIBER()
```

Required Access or Privileges

None

Required Quota

None

Related Services

\$SCANEXH, \$CREPRC, \$DCLEXH, \$DELPRC, \$EXIT, \$FORCEX, \$GETJPI, \$GETJPIW, \$PROCESS_SCAN, \$RESUME, \$SETPRI, \$SETPRN, \$SETPRV, \$SETRWM, \$SUSPND, \$WAKE

Condition Values Returned

SS\$_NORMAL

The service completed successfully.

\$ICC_ACCEPT

Accept for Intra-Cluster Communications (ICC) — Responds to an incoming connection request. This call is used to complete an ICC connection from the server side. On Alpha and Integrity server systems, this service accepts 64-bit addresses.

Format

```
SYS$ICC_ACCEPT  
    conn_handle , [accept_buf] , [accept_len] , [user_context] , [flags]
```

C Prototype

```
int sys$icc_accept  
    (unsigned int conn_handle, char * accept_buf, unsigned int accept_len,  
     unsigned int user_context, unsigned int flags);
```

Arguments

conn_handle

OpenVMS usage: connection_id
type: longword (unsigned)
access: read only
mechanism: by value

The handle of the requested connection.

accept_buf

OpenVMS usage: byte_stream
type: character-coded text string
access: read only
mechanism: by 32-bit or 64-bit reference (Alpha and Integrity servers)

A buffer of up to 1000 bytes of accept data that is sent to the source of the connection at the completion of the connection process.

accept_len

OpenVMS usage: buffer_length
type: longword (unsigned)
access: read only
mechanism: by value

The actual number of bytes in *accept_buf* to be sent.

user_context

OpenVMS usage: user_arg
type: quadword (Alpha and Integrity servers)
access: read only
mechanism: by value

A user-specified value that is subsequently returned on any disconnect or data events on this connection.

flags

OpenVMS usage: mask_longword
type: longword (unsigned)
access: read only
mechanism: by value

ICC\$M_SYNCH_MODE can be specified to indicate that the data transmission and reception routines \$ICC_TRANSMIT, \$ICC_RECEIVE, and \$ICC_REPLY are allowed to return the status SS\$_SYNCH in the case of synchronous completion, and that the AST will not be called.

Description

This service is used by a server to respond to an incoming connection request. The \$ICC_ACCEPT service may only be called after receiving a connection request AST.

At the completion of the service, the connection is open and data can be exchanged. Once opened, there is no logical distinction between a connection opened by a client with the Connect service or a server with the Accept service.

A server can reject a Connection request by calling the \$ICC_REJECT service.

Required Access or Privileges

None

Required Quota

\$ICC_ACCEPT changes the process BYTLM quota for the length of the *accept_buf* parameter, as well as a fixed value for each potential Receive buffer on the connection. The number of potential Receive buffers is specified by the MAXFLOWBUFCNT parameter in the \$ICC_OPEN_ASSOC service.

Related Services

\$ICC_CLOSE_ASSOC, \$ICC_CONNECT, \$ICC_CONNECTW, \$ICC_DISCONNECT, \$ICC_DISCONNECTW, \$ICC_OPEN_ASSOC, \$ICC_RECEIVE, \$ICC_RECEIVEW, \$ICC_REJECT, \$ICC_REPLY, \$ICC_REPLYW, \$ICC_TRANSCEIVE, \$ICC_TRANSCEIVEW, \$ICC_TRANSMIT, \$ICC_TRANSMITW

Condition Values Returned

SS\$_NORMAL

Normal completion.

SS\$_ACCVIO

Access violation on parameter.

SS\$_BADPARAM

Bad parameter value specified.

SS\$_CLEARED

Remote association closed the link before it was accepted.

SS\$_EXQUOTA

Exceeded BYTCNT/BYTLM.

SS\$_INSFARG

Too few arguments supplied.

SS\$_INSMEM

Not enough system resources or process virtual memory available.

SS\$_IVMODE

Attempted to accept a connection from a more privileged access mode than the requested association.

SS\$_IVCHAN

Connection not found or Invalid connection handle.

SS\$_LINKDISCON

The connection is valid, but the physical link has started to disconnect.

SS\$_TOO_MANY_ARGS

Too many arguments specified.

SS\$_WRONGSTATE

Connection is in the wrong state for the request.

\$ICC_CLOSE_ASSOC

Close Association for Intra-Cluster Communications (ICC) — Closes the application's association with ICC.

Format

```
SYS$ICC_CLOSE_ASSOC assoc_handle
```

C Prototype

```
int sys$icc_close_assoc (unsigned int assoc_handle);
```

Arguments

assoc_handle

OpenVMS usage: association_id
type: longword (unsigned)
access: read only
mechanism: by value

The handle of the association to be closed.

Description

This service closes the application's association with ICC. If multiple associations are open, only the specified association is closed. When an association is closed, any active connections on that association

are disconnected. If not explicitly closed by the application, associations opened in user mode will be closed at image exit; associations opened in inner modes will be closed at process termination.

All operations on an association must occur in the access mode at which the association was opened.

When an association is closed, the entry (if any) in the simple clusterwide association registry is removed.

Required Access or Privileges

None

Required Quota

None

Related Services

`$ICC_ACCEPT`, `$ICC_CONNECT`, `$ICC_CONNECTW`, `$ICC_DISCONNECT`,
`$ICC_DISCONNECTW`, `$ICC_OPEN_ASSOC`, `$ICC_RECEIVE`, `$ICC_RECEIVEW`,
`$ICC_REJECT`, `$ICC_REPLY`, `$ICC_REPLYW`, `$ICC_TRANSCEIVE`, `$ICC_TRANSCEIEW`,
`$ICC_TRANSMIT`, `$ICC_TRANSMITW`

Condition Values Returned

`SS$_NORMAL`

Normal completion.

`SS$_INSFARG`

The *assoc_handle* was not supplied.

`SS$_IVCHAN`

Invalid association handle.

`SS$_IVMODE`

Attempted to close an association from a more privileged access mode than the requested association.

`SS$_TOO_MANY_ARGS`

Too many arguments specified.

`$ICC_CONNECT`

Connect for Intra-Cluster Communications (ICC) — Establishes a connection to a remote application over an open association. On Alpha and Integrity server systems, this service accepts 64-bit addresses.

Format

`SYS$ICC_CONNECT`

```
ios_icc , [astadr] , [astprm] , assoc_handle , conn_handle , remote_assoc
, [remote_node] , [user_context] , [conn_buf] , [conn_buf_len] , [return_buf]
, [return_buf_len] , [retlen_addr] , [flags]
```

C Prototype

```
int sys$icc_connect
(struct _ios_icc *ios_icc, void (*astadr)(__unknown_params),
__int64 astprm, unsigned int assoc_handle, unsigned int *conn_handle,
void *remote_assoc, void *remote_node, unsigned int user_context,
char *conn_buf, unsigned int conn_buf_len, char *return_buf,
unsigned int return_buf_len, unsigned int *retlen_addr,
unsigned int flags);
```

Arguments

ios_icc

OpenVMS usage: io_status_block
type: quadword (unsigned)
access: write only
mechanism: by 32-bit or 64-bit reference (Alpha and Integrity servers)

I/O status block:

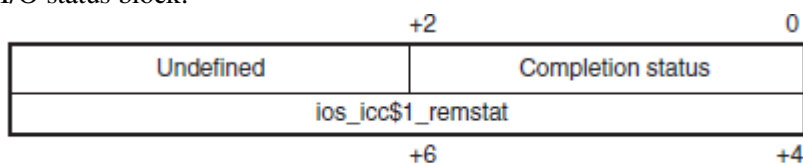

VM-0462A-AI

Completion status values:

SS\$_NORMAL, SS\$_BUFFEROVF, SS\$_EXQUOTA, SS\$_INSFMEM, SS\$_IVBUFLN,
SS\$_LINKABORT, SS\$_LINKDISCON, SS\$_NOLOGNAM, SS\$_NOSUCHOBJ,
SS\$_NOSUCHNODE, SS\$_PATHLOST, SS\$_REJECT, SS\$_SSFAIL, SS\$_UNREACHABLE,
SS\$_WRONGSTATE

The second longword is undefined unless the completion code is SS\$_REJECT. In this case, the application-defined rejection reason code is supplied by the server when \$ICC_REJECT is called.

astadr

OpenVMS usage: ast_procedure
type: procedure_entry_mask
access: call without stack unwinding
mechanism: by 32-bit or 64-bit linkage reference (Alpha and Integrity servers)

The AST routine to be executed when the operation completes.

astprm

OpenVMS usage: user_arg

type: quadword (unsigned) (Alpha and Integrity servers)
access: read only
mechanism: by 64-bit value (Alpha and Integrity servers)

The parameter to be passed to the AST routine.

assoc_handle

OpenVMS usage: association_id
type: longword (unsigned)
access: read only
mechanism: by value

The handle of the association on which the connection is to be opened. The constant `ICC$C_DFLT_ASSOC_HANDLE`, if used, indicates that the default association is to be used (and opened if necessary).

conn_handle

OpenVMS usage: longword_unsigned
type: longword (unsigned)
access: write only
mechanism: by 32-bit or 64-bit reference (Alpha and Integrity servers)

The 32-bit or 64-bit address (on Alpha and Integrity server systems) of a longword into which `$ICC_CONNECT` writes the connection handle of the created connection on a successful call.

remote_assoc

OpenVMS usage: char_string
type: character-coded text string
access: read only
mechanism: by 32-bit or 64-bit descriptor (Alpha and Integrity servers)

An ASCII character string (31 characters maximum) specifying the name of the target application to connect to. Association names are case sensitive.

remote_node

OpenVMS usage: char_string
type: character-coded text string
access: read only
mechanism: by 32-bit or 64-bit descriptor (Alpha and Integrity servers)

The name of the node where the target association resides. A null or blank string can be used to indicate the local node. If omitted (by passing zero by value), the simple clusterwide association registry is to be used. Each node name is a one-to-six character SCS node name. A comma-delimited list of nodes may be specified, indicating that one is to be chosen at random.

user_context

OpenVMS usage: user_arg
type: quadword (Alpha and Integrity servers)
access: read only
mechanism: by value

A user-specified value to be subsequently returned on any disconnect or data events on this connection.

conn_buf

OpenVMS usage: byte_stream
type: character-coded text string
access: read only
mechanism: by 32-bit or 64-bit reference (Alpha and Integrity servers)

A buffer of up to 1000 bytes of connection data to be sent to the target of the connection during the connection process.

conn_buf_len

OpenVMS usage: buffer_length
type: longword (unsigned)
access: read only
mechanism: by value

The number of bytes in *conn_buf* to be sent.

return_buf

OpenVMS usage: byte_stream
type: character-coded text string
access: read only
mechanism: by 32-bit or 64-bit reference (Alpha and Integrity servers)

A buffer of up to 1000 bytes in length to receive any incoming connection accept or reject data returned.

return_buf_len

OpenVMS usage: buffer_length
type: longword (unsigned)
access: read only
mechanism: by value

The length of the supplied *return_buf*.

retlen_addr

OpenVMS usage: longword_unsigned

type: longword (unsigned)
access: write only
mechanism: by 32-bit or 64-bit reference (Alpha and Integrity servers)

The 32-bit or 64-bit address (on Alpha and Integrity server systems) of a longword into which \$ICC_CONNECT writes the actual length (in bytes) of any user accept or reject data returned in the buffer *return_buf*.

flags

OpenVMS usage: mask_longword
type: longword (unsigned)
access: read only
mechanism: by value

ICC\$M_SYNCH_MODE can be specified to indicate that the data transmission and reception routines \$ICC_TRANSMIT, \$ICC_RECEIVE, and \$ICC_REPLY are allowed to return the status SS\$_SYNCH in the case of synchronous completion, indicating that the AST will not be called.

Description

This service establishes a connection to a remote application over an open association. Connections must be opened in the same mode as their association. If the user provides the default association constant ICC\$_DFLT_ASSOC_HANDLE as its association handle, the default association will be used; it will be opened if it is not already open. Multiple connections are possible over a single association. When completion is signaled by the AST routine, the application must check the completion status field of the IOS_ICC to determine if the server has accepted or rejected the connection request. The number of connections is subject to process BYTLM quota.

At image exit, as a result of closing any open user mode associations, all user mode connections are disconnected. Inner mode connections are the responsibility of the inner mode code, but are disconnected at process termination when inner mode associations are closed. Connections are only visible to the mode in which they were opened.

A client opens connections with the \$ICC_CONNECT service; a server opens connections with the \$ICC_ACCEPT service.

Required Access or Privileges

SYSNAM, or access via ICC Security Object. For more information, see the *VSI OpenVMS System Manager's Manual*.

Required Quota

\$ICC_CONNECT changes the process BYTLM quota for the length of the *conn_buf* parameter, as well as a fixed value for each potential Receive buffer on the connection. The number of potential Receive buffers is specified by the MAXFLOWBUFCNT parameter in the \$ICC_OPEN_ASSOC service.

If \$ICC_OPEN_ASSOC is not called before \$ICC_CONNECT, the default value of MAXFLOWBUFCNT is used (currently 5).

Related Services

\$ICC_ACCEPT, \$ICC_CLOSE_ASSOC, \$ICC_CONNECTW, \$ICC_DISCONNECT,
\$ICC_DISCONNECTW, \$ICC_OPEN_ASSOC, \$ICC_RECEIVE, \$ICC_RECEIVEW,
\$ICC_REJECT, \$ICC_REPLY, \$ICC_REPLYW, \$ICC_TRANSCEIVE, \$ICC_TRANSCEIVEW,
\$ICC_TRANSMIT, \$ICC_TRANSMITW

Condition Values Returned

SS\$_NORMAL

Normal completion.

SS\$_ACCVIO

Access violation on parameter.

SS\$_BADPARAM

Bad parameter value specified.

SS\$_BUFFEROVF

Overflow on inbound accept or reject data.

SS\$_EXQUOTA

Not enough AST quota (asynchronous request) or insufficient BYTLM/BYTCNT.

SS\$_INSFARG

Too few arguments were supplied, or required arguments not supplied.

SS\$_INSFMEM

Not enough system resources or process virtual memory available.

SS\$_INSFP1POOL

Not enough process P1 space available.

SS\$_IVBUFLN

The length of the context data or the accept or reject data buffer is more than 1000 bytes.

SS\$_IVCHAN

Invalid association handle.

SS\$_IVMODE

Attempted to open a connection from a more privileged access mode than the requested association.

SS\$_LINKABORT

The communications link to the target node was lost.

SS\$_LINKDISCON

The communications link to the target node was lost.

SS\$_NOLINKS

Too many connections open.

SS\$_NOLOGNAM

The underlying layers failed to start properly during system initialization.

SS\$_NOPRIV

No privilege to connect to the specified association. Connection access is granted either through an ICC security object or through the SYSNAM privilege. If no security object exists and the caller lacks the SYSNAM privilege, SS\$_NOPRIV is returned rather than SS\$_NOSUCHOBJ.

SS\$_NOSUCHOBJ

The remote association name and/or node was not found.

SS\$_NOSUCHNODE

The target node is not known.

SS\$_PATHLOST

The communications link to the target node was lost.

SS\$_REMRSRC

Insufficient resources at remote node.

SS\$_REJECT

The remote association or node rejected the connection request.

SS\$_TOO_MANY_ARGS

Too many arguments specified.

SS\$_UNREACHABLE

Target node currently unreachable.

SS\$_WRONGSTATE

Connection is in the wrong state for the request.

\$ICC_CONNECTW

Connect for Intra-Cluster Communications and Wait — Establishes a link between two ICC associations. The \$ICC_CONNECTW service completes synchronously; that is, it returns to the caller after the server has either accepted or rejected the connection request. For asynchronous completion, use the

\$ICC_CONNECT service; **\$ICC_CONNECT** returns to the caller as soon as the connection request has been sent to the server, without waiting for a response from the server. On Alpha and Integrity server systems, this service accepts 64-bit addresses.

Format

```
SYS$ICC_CONNECTW
  ios_icc , [astadr] , [astprm] , assoc_handle , conn_handle , remote_assoc
  , [remote_node] , [user_context] , [conn_buf] , [conn_buf_len] , [return_buf]
  , [return_buf_len] , [retlen_addr] , [flags]
```

C Prototype

```
int sys$icc_connectw
(struct _ios_icc *ios_icc, void (*astadr)(__unknown_params),
 __int64 astprm, unsigned int assoc_handle, unsigned int *conn_handle,
 void *remote_assoc, void *remote_node, unsigned int user_context,
 char *conn_buf, unsigned int conn_buf_len, char *return_buf,
 unsigned int return_buf_len, unsigned int *retlen_addr,
 unsigned int flags);
```

\$ICC_DISCONNECT

Disconnect for Intra-Cluster Communications (ICC) — Terminates the specified connection. On Alpha and Integrity server systems, this service accepts 64-bit addresses.

Format

```
SYS$ICC_DISCONNECT
  conn_handle , iosb , [astadr] , [astprm] , [disc_buf] , [disc_buf_len]
```

C Prototype

```
int sys$icc_disconnect
(unsigned int conn_handle, struct _iosb, *iosb,
 void (*astadr)(__unknown_params), __int64 astprm, char * disc_buf,
 unsigned int disc_buf_len);
```

Arguments

conn_handle

OpenVMS usage: connection_id
type: longword (unsigned)
access: read only
mechanism: by value

The ID of the connection to be disconnected.

iosb

OpenVMS usage: io_status_block

type: quadword (unsigned)
 access: write only
 mechanism: by 32-bit or 64-bit reference (Alpha and Integrity servers)

I/O status block:

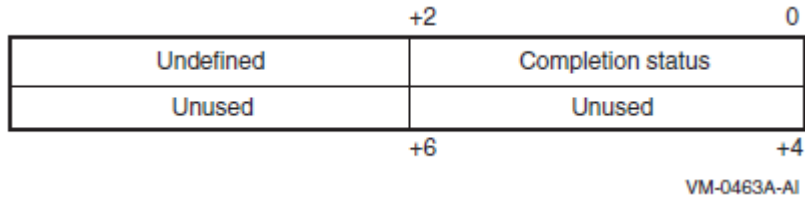

Completion status values:

SS\$_NORMAL, SS\$_EXQUOTA, SS\$_LINKDISCON, \$ICC_REJECT

astadr

OpenVMS usage: ast_procedure
 type: procedure_entry_mask
 access: call without stack unwinding
 mechanism: by 32-bit or 64-bit linkage reference (Alpha and Integrity servers)

The AST routine to be executed when the operation completes.

astprm

OpenVMS usage: user_arg
 type: quadword (unsigned) (Alpha and Integrity servers)
 access: read only
 mechanism: by 64-bit value (Alpha and Integrity servers)

The parameter to be passed to the AST routine.

disc_buf

OpenVMS usage: byte_stream
 type: character-coded text string
 access: read only
 mechanism: by 32-bit or 64-bit reference (Alpha and Integrity servers)

A buffer of up to 1000 bytes of disconnect data to be sent to the partner in the connection when notifying it that disconnection is being initiated. Delivery of this data is not guaranteed.

disc_buf_len

OpenVMS usage: buffer_length
 type: longword (unsigned)
 access: read only

mechanism: by value

The number of bytes in *disc_buf* to be sent.

Description

This service must be called in the mode in which the association was opened.

This service terminates the specified connection. After this service is called, no further communication is possible over this connection. All outstanding data transmission and reception functions are terminated with an error before completion is signaled by calling the AST (if supplied).

A connection may be disconnected by either party. Proper programming procedure for network communications strongly recommends that the party that last received a message initiate the disconnection. If the party that last sent a message initiates the disconnection, there is no guarantee that the message was delivered.

Similarly, although this interface provides the ability to send disconnect data, only noncritical information should be transmitted with the disconnect data mechanism, because there is no guarantee that the data will have been received or acted upon by the other party to the connection.

Required Access or Privileges

None

Required Quota

BYTLM (*disc_buf*)

Related Services

\$ICC_ACCEPT, \$ICC_CLOSE_ASSOC, \$ICC_CONNECT, \$ICC_CONNECTW,
\$ICC_DISCONNECTW, \$ICC_OPEN_ASSOC, \$ICC_RECEIVE, \$ICC_RECEIVEW,
\$ICC_REJECT, \$ICC_REPLY, \$ICC_REPLYW, \$ICC_TRANSCEIVE, \$ICC_TRANSCEIVEW,
\$ICC_TRANSMIT, \$ICC_TRANSMITW

Condition Values Returned

SS\$_NORMAL

Normal completion.

SS\$_ACCVIO

Access violation on parameter.

SS\$_BADPARAM

Bad parameter value specified.

SS\$_INSFMEM

Not enough nonpaged pool.

SS\$_IVBUFLN

The length of the disconnect data buffer is more than 1000 bytes.

SS\$_IVCHAN

Unknown connection specified or invalid connection handle.

SS\$_IVMODE

Attempted to disconnect a connection from a more privileged access mode than the requested connection.

SS\$_LINKDISCON

The remote association closed the connection before it was accepted or rejected.

SS\$_TOO_MANY_ARGS

Too many arguments specified.

\$ICC_DISCONNECTW

Disconnect and Wait for Intra-Cluster Communications (ICC) — Terminates a link between two ICC associations. The `$ICC_DISCONNECTW` service completes synchronously; that is, it returns to the caller after the connection has completely finished the disconnection request. For asynchronous completion, use the `$ICC_DISCONNECT` service; `$ICC_DISCONNECT` returns to the caller as soon as the disconnection request has been sent to the transport layer, without waiting for notification that the disconnection has completed. On Alpha and Integrity server systems, this service accepts 64-bit addresses.

Format

```
SYS$ICC_DISCONNECTW
    conn_handle , iosb , [astadr] , [astprm] , [disc_buf] , [disc_buf_len]
```

C Prototype

```
int sys$icc_disconnectw
    (unsigned int conn_handle, struct _iosb, *iosb,
     void (*astadr)(__unknown_params), __int64 astprm, char * disc_buf,
     unsigned int disc_buf_len);
```

\$ICC_OPEN_ASSOC

Open Association for Intra-Cluster Communications (ICC) — Declares an application association with ICC. On Alpha and Integrity server systems, this service accepts 64-bit addresses.

Format

```
SYS$ICC_OPEN_ASSOC
    assoc_handle , [assoc_name] , [logical_name] , [logical_table]
    , [conn_event_rtn] , [disc_event_rtn] , [recv_rtn] , [maxflowbufcnt]
    , [prot]
```

C Prototype

```
int sys$icc_open_assoc
(unsigned int *assoc_handle, void *assoc_name, void *logical_name,
 void *logical_table, void (*conn_event_rtn)(__unknown_params),
 void (*disc_event_rtn)(__unknown_params),
 void (*recv_rtn)(__unknown_params), unsigned int maxflowbufcnt,
 unsigned int prot);
```

Arguments

assoc_handle

OpenVMS usage: association_id
type: longword (unsigned)
access: write only
mechanism: by 32-bit or 64-bit reference (Alpha and Integrity servers)

The 32-bit or 64-bit address (on Alpha and Integrity server systems) into which \$ICC_OPEN_ASSOC writes the handle assigned to the opened association.

assoc_name

OpenVMS usage: char_string
type: character-coded text string
access: read only
mechanism: by 32-bit or 64-bit descriptor (Alpha and Integrity servers)

An ASCII character string of up to 31 characters in length specifying the name of the application opening the association. Null (0 length), and empty or blank association names are not allowed. If this argument is omitted (that is, a zero is passed in by value), it signifies that the user wants to open the default association. This argument is case sensitive.

logical_name

OpenVMS usage: logical name
type: character-coded text string
access: read only
mechanism: by 32-bit or 64-bit descriptor (Alpha and Integrity servers)

A logical name in a clusterwide logical name table used to maintain the simple association registry. The logical name represents the name of the service provided by the application. Logical names are case sensitive.

logical_table

OpenVMS usage: logical name table
type: character-coded text string
access: read only
mechanism: by 32-bit or 64-bit descriptor (Alpha and Integrity servers)

The table containing the logical name *logical_name*. Logical name tables are converted to uppercase. Unless your application requires an application-specific logical name table, this argument should be either the default ICC Registry search list (ICC\$REGISTRY), or the default registry table (ICC\$REGISTRY_TABLE).

conn_event_rtn

OpenVMS usage: user_routine
type: procedure_entry_mask
access: call without stack unwinding
mechanism: by 32-bit or 64-bit linkage reference (Alpha and Integrity servers)

The address of the AST routine to be called for incoming connect events. This routine will be called in the mode of the caller. (No mechanism is provided for the routine to be called at a different mode).

You must have a *conn_event_rtn* to operate as a server.

disc_event_rtn

OpenVMS usage: user_routine
type: procedure_entry_mask
access: call without stack unwinding
mechanism: by 32-bit or 64-bit linkage reference (Alpha and Integrity servers)

The address of the AST routine to be called for incoming disconnect events. This routine will be called in the mode of the caller. (No mechanism is provided for the routine to be called at a different mode). The arguments, *conn_event_rtn*, and *disc_event_rtn*, may reference the same routine.

recv_rtn

OpenVMS usage: user_routine
type: procedure_entry_mask
access: call without stack unwinding
mechanism: by 32-bit or 64-bit linkage reference (Alpha and Integrity servers)

The address of the AST routine to be called for incoming new data events.

If the user provides this routine, it indicates that the user will supply a buffer of the size required (specified in an argument to the *recv_rtn* at each call) each time one is requested. If the user supplies this routine, receive calls should only be issued after receive events arrive and sufficient buffer space has been allocated to handle the incoming data.

This routine will be called in the mode of the caller. (No mechanism is provided for the routine to be called at a different mode).

maxflowbufcnt

OpenVMS usage: longword_unsigned
type: longword (unsigned)
access: read only

mechanism: by value

The maximum number of pending inbound messages (per connection) that ICC will allow the user before initiating flow control. A message is pending if it is being held within ICC but no receive call(s) are outstanding from the user.

Default = 5 (Pass 0 to get the default)

prot

OpenVMS usage: longword_unsigned
type: longword (unsigned)
access: read only
mechanism: by value

This argument is ignored for non-server applications.

The default protection scheme for this association is as follows:

0 - access for everyone (default)

1 - stops WORLD access

2 - stops both WORLD and GROUP access

Advanced access control is provided by ICC Security objects. For information about ICC system management and security, see the *VSI OpenVMS System Manager's Manual*.

Description

This service declares an application association with ICC. Servers must make this call to declare or register their name and to indicate their readiness to receive incoming connections. Although a client is permitted to call this routine, it is unnecessary for simple applications. A client application that wishes to be notified of disconnection events or Receive Data events must call the \$ICC_OPEN_ASSOC service.

A client can open a connection without specifying an open association; this automatically creates a default association name of ICC\$PID_nnnnnnnn (where nnnnnnnn is a character representation of the Process ID).

NETMBX privilege is required to open any association.

The association name space is a controlled resource. For information about managing this resource, see the *VSI OpenVMS System Manager's Manual*.

An attempt to open an association with a name not authorized as described in the *VSI OpenVMS System Manager's Manual* will fail with the error SSS_NOPRIV returned to the caller. In addition to making entries in the system's local association name space, a call to \$ICC_OPEN_ASSOC may also make an entry in a simple clusterwide registry of active associations.

An association may only be accessed from the mode in which it was opened. Inner modes are prevented from using the default association.

An application can open any number of associations subject to available process BYTLM quota. Currently, there is a systemwide limit of 512 open associations. There is no limit imposed clusterwide.

Description of User-Supplied Routines (ASTs)

When opening an association, the user may optionally supply a connect/disconnect AST and/or a Data Event AST. These routines will be used for all connections established over the specified association. In addition, for any of the asynchronous services (those provided with both an immediate return and a "W" form), a completion AST may be supplied by the user. This section describes these ASTs.

1. Connect and Disconnect AST

The user chooses the name of this routine and supplies the procedure name as an argument to the Open Association service. Seven arguments will be passed to the user.

The first argument notifies the user whether this is an incoming new connection or a disconnection of an existing connection. The second identifies the connection. The third and fourth provide access to incoming connect or disconnect data (if any) sent by the cooperating application. The fifth argument provides the number of bytes available for any optional Accept or Reject data (in the case of a connect request) or the disconnect reason supplied by the cooperating application (if any).

For connect events, the sixth and seventh arguments are the EPID and user name of the process requesting the connect, respectively.

The user has the choice of using and declaring a common routine or separate routines as specified when calling \$OPEN_ASSOCIATION.

Format

```
ConnDiscRtn  event_type , conn_handle , data_len , data_bfr , P5 , P6 , P7
```

C Prototype

```
void ConDiscRtn
(unsigned int event_type, unsigned int conn_handle,
 unsigned int data_len, char *data_bfr,
 unsigned int P5, unsigned int P6, char *P7);
```

Arguments

event_type

Type: longword (unsigned)
Access: read only
Mechanism: by value

This field will contain a code describing the type of event. The possible event codes are defined in ICCDEF:

```
ICC$C_EV_CONNECT      - Connection event
ICC$C_EV_DISCONNECT  - Disconnection event
```

conn_handle

Type: longword (unsigned)
Access: read only
Mechanism: by value

The handle of the connection associated with the event.

data_len

Type: longword (unsigned)
Access: read only
Mechanism: by value

The length (in bytes) of the incoming data. This value specifies the length of the buffer *data_bfr*, and will be between 0 and 1000, with zero indicating no data.

data_bfr

Type: character-coded text string
Access: read only
Mechanism: by 32-bit or 64-bit value (Alpha and Integrity servers)

The 32-bit address of the P1-space buffer containing the data, or zero if no data is available. The length of this buffer is specified by the argument *data_len*.

Upon return from the AST, the address of the data is no longer valid. An application wishing to reference the Connection or Disconnection data after Return must copy the data from the supplied buffer to storage owned by the application.

P5

Type: longword (unsigned)
Access: read only
Mechanism: by value

The usage of this argument is dependent on the specified event type code (*event_type*).

For connect events (*event_type*=ICCS\$EV_CONNECT), this argument contains the length (in bytes) of the buffer available for a reply.

For disconnect events (*event_type*=ICCS\$EV_DISCONNECT), this argument contains the user-defined disconnect reason/status from the remote partner.

P6

Type: quadword (Alpha and Integrity servers)
Access: read only
Mechanism: by value

The usage of this argument is dependent on the specified event type code (*event_type*).

For connect events (*event_type*=ICCS\$EV_CONNECT), this argument contains the EPID of the process requesting the connection, passed by value.

For disconnect events (*event_type*=ICCS\$EV_DISCONNECT), this argument contains the user-defined *user_context* supplied when the connection was opened. For a client, the *user_context* is that supplied to the \$ICC_CONNECT call. For a server, it is the value supplied to \$ICC_ACCEPT.

P7

Type: character-coded text string
Access: read only
Mechanism: by reference

For connect events: Username, passed by reference (to P1 space buffer) as a 12-character, space-filled string.

The application must copy this information to local storage before exiting from the connect routine.

For disconnect events, this argument is zero (0).

2. Data Event Routine

This routine, if supplied by the user when opening the association, allows the user to be notified of any pending data events over any connections subsequently opened over that association.

If the user has supplied this routine, the Receive service must only be called in response to incoming data events signaled by this routine, and must be called with a buffer large enough to handle the message size specified.

Use of this routine obligates the user to allocate buffers up to the size requested by the cooperating application. The only recovery provided at this time if a sufficiently large buffer cannot be allocated is to disconnect the connection. Failure to issue a receive call or disconnect may stall all further communication on this connection.

Format

```
DataEventRtn message_size ,conn_handle ,user_context
```

C Prototype

```
void DataEventRtn  
    (unsigned int message_size, unsigned int conn_handle,  
     unsigned int user_context);
```

Arguments

message_size

Type: longword (unsigned)
Access: read only
Mechanism: by value

This field will contain the number of bytes in the pending data event.

conn_handle

Type: longword (unsigned)
Access: read only
Mechanism: by value

The handle of the connection associated with the event. This value should be used as the *conn_handle* argument to \$ICC_RECEIVE.

user_context

Type: quadword (Alpha and Integrity servers)
Access: read only
Mechanism: by value

The user-defined *user_context* supplied when the connection was opened. For a client, the user context is that supplied to the \$ICC_CONNECT call. For a server, it is the value supplied to \$ICC_ACCEPT.

3. Completion ASTs

Completion ASTs may be supplied to the \$ICC_CONNECT[W], \$ICC_DISCONNECT[W], \$ICC_TRANSMIT[W], \$ICC_RECEIVE[W], \$ICC_TRANSCEIVE[W], and \$ICC_REPLY[W] services. In all cases, they are called at the completion of the requested operation, with the single argument, the AST parameter supplied when the original service was called, passed by value.

Completion ASTs are not called if the service returns an error prior to initiating the operation. \$ICC_CONNECT and \$ICC_ACCEPT accept the flag ICC\$V_SYNCH_MODE which indicates that the routines \$ICC_TRANSMIT[W], \$ICC_RECEIVE[W], and \$ICC_REPLY[W] are permitted to return the status SS\$_SYNCH, which will indicate that completion has already occurred and the AST will not be called.

Required Access or Privileges

For more information, see the *VSI OpenVMS System Manager's Manual*.

Required Quota

BYTCNT, BYTLM

Related Services

\$ICC_ACCEPT, \$ICC_CLOSE_ASSOC, \$ICC_CONNECT, \$ICC_CONNECTW, \$ICC_DISCONNECT, \$ICC_DISCONNECTW, \$ICC_RECEIVE, \$ICC_RECEIVEW, \$ICC_REJECT, \$ICC_REPLY, \$ICC_REPLYW, \$ICC_TRANSCEIVE, \$ICC_TRANSCEIVEW, \$ICC_TRANSMIT, \$ICC_TRANSMITW

Condition Values Returned

SS\$_NORMAL

Normal completion.

SS\$_ACCVIO

Access violation on parameter.

SS\$_BADPARAM

Bad parameter value specified.

SS\$_DUPLNAM

Specified association name is already registered (already exists), or default association is already open.

SS\$_EXQUOTA

One or more process quotas has been exceeded (probably BYTCNT/BYTLM).

SS\$_INSFARG

Too few arguments supplied.

SS\$_INSFMEM

Not enough system resources or process virtual memory available.

SS\$_IVMODE

Attempt to open default association from other than user mode.

SS\$_NOLINKS

Too many associations open for this process.

SS\$_NONETMBX

Request requires NETMBX privilege.

SS\$_NOPRIV

No privilege for association name access or logical name table access if using the Registry.

SS\$_SSFAIL

Transport association name table is full, systemwide.

SS\$_TOO_MANY_ARGS

Too many arguments were specified. Any failures from the system services: \$ENQ, \$DEQ, \$CRELNM, \$TRNLNM.

\$ICC_RECEIVE

Receive for Intra-Cluster Communications (ICC) — Receives a single message over a connection. On Alpha and Integrity server systems, this service accepts 64-bit addresses.

Format

```
SY$_ICC_RECEIVE
  conn_handle , ios_icc , [astadr] , [astprm] , recv_buf , recv_buf_len
```

C Prototype

```
sys$icc_receive
(unsigned int conn_handle, struct _ios_icc *ios_icc,
 void (*astadr)(__unknown_params), __int64 astprm,
 char *recv_buf, unsigned int recv_buf_len);
```

Arguments

conn_handle

OpenVMS usage: connection_id
type: longword (unsigned)
access: read only
mechanism: by value

The handle of the fully established connection.

ios_icc

OpenVMS usage: io_status_block
type: four longwords (unsigned)

access: write only
 mechanism: by 32-bit or 64-bit reference (Alpha and Integrity servers)

I/O status block:

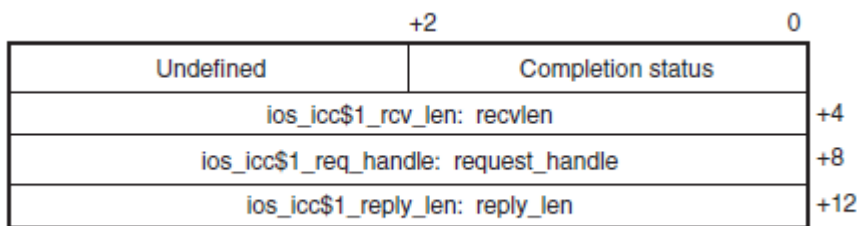

VM-0464A-AI

Completion codes:

SS\$_NORMAL, SS\$_EXQUOTA, SS\$_INSFMEM, SS\$_LINKDISCON, SS\$_BUFOVL,
 SS\$_ACCVIO

astadr

OpenVMS usage: ast_procedure
 type: procedure_entry_mask
 access: call without stack unwinding
 mechanism: by 32-bit or 64-bit linkage reference (Alpha and Integrity servers)

The AST routine to be executed when the operation completes.

astprm

OpenVMS usage: user_arg
 type: quadword (unsigned) (Alpha and Integrity servers)
 access: read only
 mechanism: by 64-bit value (Alpha and Integrity servers)

The parameter to be passed to the AST routine.

recv_buf

OpenVMS usage: byte_stream
 type: character-coded text string
 access: read only
 mechanism: by 32-bit or 64-bit reference (Alpha and Integrity servers)

The 32-bit or 64-bit address (on Alpha and Integrity server systems) of the buffer to receive the incoming data. The length of this buffer is specified by the argument *recv_buf_len*.

recv_buf_len

OpenVMS usage: buffer_length
 type: longword (unsigned)
 access: read only

mechanism: by value

The length (in bytes) of the buffer available to hold the incoming data. This value specifies the length of the buffer *recv_buf*.

IOS_ICC Arguments:

recvlen (output)

OpenVMS usage: longword unsigned
type: longword (unsigned)
access: write only
mechanism: by value

This parameter is returned in the *ios_icc*. \$ICC_RECEIVE writes the actual length of the incoming data message received from the target application (in bytes) into offset *ios_icc\$l_rcv_len* of the *ios_icc*.

request_handle (output)

OpenVMS usage: request_id
type: longword (unsigned)
access: write only
mechanism: by value

This parameter is returned in the *ios_icc*. \$ICC_RECEIVE writes the Request/Response handle into offset *ios_icc\$l_req_handle* of the *ios_icc*. The *request_handle* argument is nonzero if the application is expected to reply to this message.

reply_len (output)

OpenVMS usage: longword_unsigned
type: longword (unsigned)
access: write only
mechanism: by value

This parameter is returned in the *ios_icc*. The \$ICC_RECEIVE service writes the maximum length (in bytes) of the expected Reply message into offset *ios_icc\$l_reply_len* of the *ios_icc*, if *request_handle* is nonzero.

Description

This service receives a single message over a connection. If a Request ID is returned at completion, the partner has used a Transceive system service and requires data to be returned with a Reply service.

For efficiency reasons, the number of parameters on this routine has been limited to six parameters. Three additional values are returned by the *ios_icc* data structure.

Required Access or Privileges

None

Required Quota

BYTLM

Related Services

\$ICC_ACCEPT, \$ICC_CLOSE_ASSOC, \$ICC_CONNECT, \$ICC_CONNECTW,
\$ICC_DISCONNECT, \$ICC_DISCONNECTW, \$ICC_OPEN_ASSOC, \$ICC_RECEIVEW,
\$ICC_REJECT, \$ICC_REPLY, \$ICC_REPLYW, \$ICC_TRANSCEIVE, \$ICC_TRANSCEIVEW,
\$ICC_TRANSMIT, \$ICC_TRANSMITW

Condition Values Returned

SS\$_NORMAL

Normal completion.

SS\$_ACCVIO

Access violation on parameter.

SS\$_EXBYTLM

Insufficient byte count quota.

SS\$_EXQUOTA

One or more process quotas has been exceeded.

SS\$_INSFARG

Too few arguments supplied.

SS\$_IVCHAN

Unknown connection specified or invalid connection handle.

SS\$_IVMODE

Attempted to use a connection from a more privileged access mode than the mode in which it was opened.

SS\$_LINKDISCON

The connection has been disconnected.

SS\$_SYNCH

If synchronous mode was requested at connection time, this return value indicates that completion has already occurred and the AST routine, if specified, will not be called.

SS\$_TOO_MANY_ARGS

Too many arguments specified.

SS\$_WRONGSTATE

Connection is in the wrong state for the request.

\$ICC_RECEIVEW

Receive and Wait for Intra-Cluster Communications (ICC) — The Intra-Cluster Communications Receive and Wait service queues a receive request to the specified connection. The \$ICC_RECEIVEW service completes synchronously; that is, it returns to the caller with data. For asynchronous completion, use the \$ICC_RECEIVE service; \$ICC_RECEIVE returns to the caller as soon as the receive request is queued, without waiting for data on the connection. On Alpha and Integrity server systems, this service accepts 64-bit addresses.

Format

```
SY$_ICC_RECEIVEW
    conn_handle , ios_icc , [astadr] , [astprm] , recv_buf , recv_buf_len
```

C Prototype

```
sys$icc_receivew
    (unsigned int conn_handle, struct _ios_icc *ios_icc,
     void (*astadr)(__unknown_params), __int64 astprm,
     char *recv_buf, unsigned int recv_buf_len);
```

\$ICC_REJECT

Reject for Intra-Cluster Communications (ICC) — Refuses a connection request. On Alpha and Integrity server systems, this service accepts 64-bit addresses.

Format

```
SY$_ICC_REJECT
    conn_handle, [reject_buf], [reject_buf_len], [reason]
```

C Prototype

```
int sys$icc_reject
    (unsigned int conn_handle, char * reject_buf,
     unsigned int reject_buf_len, unsigned int reason);
```

Arguments

conn_handle

OpenVMS usage: connection_id
type: longword (unsigned)
access: read only
mechanism: by value

The handle of the requested connection.

reject_buf

OpenVMS usage: byte_stream
type: character-coded text string
access: read only
mechanism: by 32-bit or 64-bit reference (Alpha and Integrity servers)

A buffer of up to 1000 bytes of reject data to be sent to the source of the connection at the completion of the rejection process.

reject_buf_len

OpenVMS usage: buffer_length
type: longword (unsigned)
access: read only
mechanism: by value

The number of bytes in *reject_buf* to be sent.

reason

OpenVMS usage: cond_code
type: longword (unsigned)
access: read only
mechanism: by value

User-specified reject reason code to be supplied to the remote application.

Default = SS\$_REJECT

Description

This service is used by a server to refuse an incoming connection request. The \$ICC_REJECT service may only be called after receiving a connection request AST. After the completion of the service, the client is notified that the connection was not opened.

Required Access or Privileges

None

Required Quota

None

Related Services

\$ICC_ACCEPT, \$ICC_CLOSE_ASSOC, \$ICC_CONNECT, \$ICC_CONNECTW,
\$ICC_DISCONNECT, \$ICC_DISCONNECTW, \$ICC_OPEN_ASSOC, \$ICC_RECEIVE,
\$ICC_RECEIVEW, \$ICC_REPLY, \$ICC_REPLYW, \$ICC_TRANSCEIVE, \$ICC_TRANSCEIVEW,
\$ICC_TRANSMIT, \$ICC_TRANSMITW

Condition Values Returned

SS\$_NORMAL

Normal completion.

SS\$_ACCVIO

Access violation on parameter.

SS\$_BADPARAM

Bad parameter value specified.

SS\$_CLEARED

Remote association closed the link before it was rejected.

SS\$_INSFARG

Too few arguments supplied.

SS\$_IVCHAN

Connection not found or Invalid connection handle.

SS\$_LINKDISCON

The transport layer has initiated disconnect before the Reject could be sent to the requester.

SS\$_TOO_MANY_ARGS

Too many arguments specified.

SS\$_WRONGSTATE

Connection is already open and cannot be rejected. To close the connection, call \$ICC_DISCONNECT.

\$ICC_REPLY

Reply for Intra-Cluster Communications (ICC) — Sends a single message over a connection. This service is used in response to the reception of a Request Handle in a previous \$ICC_RECEIVE system service. On Alpha and Integrity server systems, this service accepts 64-bit addresses.

Format

```
SYS$ICC_REPLY
    conn_handle , ios_icc , [astadr] , [astprm] , reply_buf , reply_len
```

C Prototype

```
sys$icc_reply
(unsigned int conn_handle, struct _ios_icc *ios_icc,
 void (*astadr)(__unknown_params), __int64 astprm, char *reply_buf,
 unsigned int reply_len);
```

Arguments

conn_handle

OpenVMS usage: connection_id
type: longword (unsigned)
access: read only
mechanism: by value

The handle of the fully established connection.

ios_icc

OpenVMS usage: io_status_block
type: quadword (unsigned)
access: modify
mechanism: by 32-bit or 64-bit reference (Alpha and Integrity servers)

I/O status block:

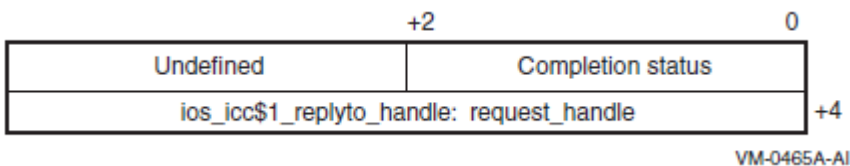

Completion status values:

SS\$_NORMAL, SS\$_EXQUOTA, SS\$_INSFMEM, SS\$_LINKABORT, SS\$_LINKDISCON

astadr

OpenVMS usage: ast_procedure
type: procedure_entry_mask
access: call without stack unwinding
mechanism: by 32-bit or 64-bit linkage reference (Alpha and Integrity servers)

The AST routine to be executed when the operation completes.

astprm

OpenVMS usage: user_arg
type: quadword (unsigned) (Alpha and Integrity servers)
access: read only
mechanism: by 64-bit value (Alpha and Integrity servers)

The parameter to be passed to the AST routine.

reply_buf

OpenVMS usage: byte_stream
type: character-coded text string

access: read only
mechanism: by 32-bit or 64-bit reference (Alpha and Integrity servers)

The 32-bit or 64-bit address (on Alpha and Integrity server systems) of the buffer containing the reply data to be sent. The length of this buffer is specified by the argument *reply_len*.

reply_len

OpenVMS usage: *buffer_length*
type: longword (unsigned)
access: read only
mechanism: by value

The length (in bytes) of the reply data to be sent over the connection. This value specifies the length of the buffer *reply_buf*. ICC segments larger buffers internally.

The maximum Reply length is the smaller of the Reply buffer size supplied in the \$ICC_RECEIVE call, or 1MB.

IOS_ICC Argument:

request_handle (input)

OpenVMS usage: *request_id*
type: longword (unsigned)
access: read only
mechanism: by value

This parameter is passed through the *ios_icc*. The Request/Response handle from the received Transceive request is placed at offset *ios_icc\$l_replyto_handle* of the *ios_icc*.

Description

This service is almost identical to the \$ICC_TRANSMIT system service in that it sends a single message over a connection. The only difference is that it is used in response to the reception of a Request Handle in a previous Receive Data system service.

When completion is signaled by calling the AST (if supplied), the data has been delivered to the communications system, but not necessarily to the application at the other end of the connection. The user can reuse the buffer after completion has been signaled.

Alternatively, if the synchronous completion option was requested at connection time, the service may return the optional success status, SS\$_SYNCH. When SS\$_SYNCH is returned, completion has occurred, and no AST will be delivered.

Required Access or Privileges

None

Required Quota

BYTLM (for Reply buffer)

Related Services

\$ICC_ACCEPT, \$ICC_CLOSE_ASSOC, \$ICC_CONNECT, \$ICC_CONNECTW,
\$ICC_DISCONNECT, \$ICC_DISCONNECTW, \$ICC_OPEN_ASSOC, \$ICC_RECEIVE,
\$ICC_RECEIVEW, \$ICC_REJECT, \$ICC_REPLYW, \$ICC_TRANSCEIVE, \$ICC_TRANSCEIVEW,
\$ICC_TRANSMIT, \$ICC_TRANSMITW

Condition Values Returned

SS\$_NORMAL

Normal completion.

SS\$_ACCVIO

Access violation on parameter.

SS\$_BADPARAM

Bad parameter value specified.

SS\$_EXBYTLM

Insufficient byte count quota.

SS\$_INSFARG

Too few arguments supplied.

SS\$_IVCHAN

Unknown connection specified or invalid connection handle.

SS\$_IVMODE

Attempted to use a connection from a more privileged access mode than the mode in which it was opened.

SS\$_LINKDISCON

An Incoming disconnect event is already in progress.

SS\$_NOSUCHID

The *request_handle* is invalid.

SS\$_SYNCH

If synchronous mode was requested at connection time, this return value indicates that completion has already occurred and the AST routine, if specified, will not be called.

SS\$_TOO_MANY_ARGS

Too many arguments specified.

SS\$_WRONGSTATE

Connection is in the wrong state for the request.

\$ICC_REPLYW

Reply and Wait for Intra-Cluster Communications (ICC) — The Intra-Cluster Communications Reply and Wait service transmits a single message over a connection in response to a \$ICC_TRANSCEIVE[W] request. The \$ICC_REPLYW service completes synchronously; that is, it returns to the caller when the underlying transport layer has released use of the reply buffer. For asynchronous completion, use the \$ICC_REPLY service; \$ICC_REPLY returns to the caller as soon as the transmission request has been queued to the transport layer, without waiting for notification that the transport layer has released control of the data buffer. On Alpha and Integrity server systems, this service accepts 64-bit addresses.

Format

```
SY$ICC_REPLYW
    conn_handle, ios_icc, [astadr], [astprm], reply_buf, reply_len
```

C Prototype

```
sys$icc_replyw
    (unsigned int conn_handle, struct _ios_icc *ios_icc,
     void (*astadr)(__unknown_params), __int64 astprm,
     char *reply_buf, unsigned int reply_len);
```

\$ICC_TRANSCEIVE

Transceive for Intra-Cluster Communications (ICC) — Sends a single message over a connection and then waits for a reply. On Alpha and Integrity server systems, this service accepts 64-bit addresses.

Format

```
SY$ICC_TRANSCEIVE
    conn_handle , ios_icc , [astadr] , [astprm] , send_buf , send_len
```

C Prototype

```
sys$icc_transceive
    (unsigned int conn_handle, struct _ios_icc *ios_icc,
     void (*astadr)(__unknown_params), __int64 astprm, char *send_buf,
     unsigned int send_len);
```

Arguments

conn_handle

OpenVMS usage: connection_id
type: longword (unsigned)
access: read only
mechanism: by value

The handle of the fully established (open) connection.

ios_icc

OpenVMS usage: io_status_block
 type: five longwords (unsigned)
 access: modify
 mechanism: by 32-bit or 64-bit reference (Alpha and Integrity servers)

I/O status block:

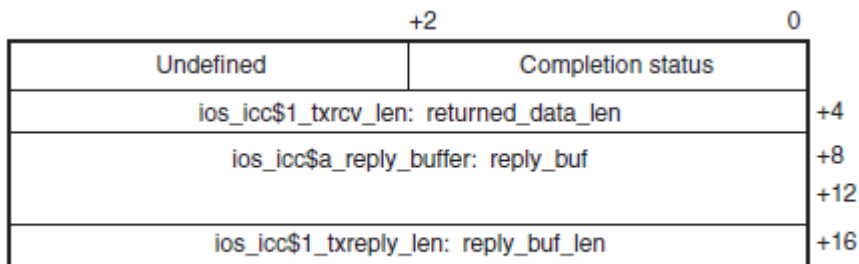

VM-0466A-AI

Completion status values:

SS\$_NORMAL, SS\$_EXQUOTA, SS\$_INSFMEM, SS\$_BUFOVFL, SS\$_LINKABORT,
 SS\$_LINKDISCON

astadr

OpenVMS usage: ast_procedure
 type: procedure_entry_mask
 access: call without stack unwinding
 mechanism: by 32-bit or 64-bit linkage reference (Alpha and Integrity servers)

The AST routine to be executed when the operation completes.

astprm

OpenVMS usage: user_arg
 type: quadword (unsigned) (Alpha and Integrity servers)
 access: read only
 mechanism: by 64-bit value (Alpha and Integrity servers)

The parameter to be passed to the AST routine.

send_buf

OpenVMS usage: byte_stream
 type: character-coded text string
 access: read only
 mechanism: by 32-bit or 64-bit reference (Alpha and Integrity servers)

The 32-bit or 64-bit address (on Alpha and Integrity server systems) of the buffer containing the data to be sent. The length of this buffer is specified by the argument *send_len*.

send_len

OpenVMS usage: buffer size
type: longword (unsigned)
access: read only
mechanism: by value

The length (in bytes) of the data to be sent over the connection. This value specifies the length of the buffer *send_buf*.

IOS_ICC Arguments:**returned_data_len (output)**

OpenVMS usage: longword_unsigned
type: longword (unsigned)
access: write only
mechanism: by value

This parameter is passed through the *ios_icc*. The \$ICC_TRANSCEIVE service writes the actual length (in bytes) of the reply data received into offset *ios_icc\$l_txrcv_len* of the *ios_icc*. This value represents how much data in *reply_buf* was returned by the target application.

reply_buf (input)

OpenVMS usage: byte_stream
type: character-coded text string
access: write only
mechanism: by 32-bit or 64-bit reference (Alpha and Integrity servers)

This parameter is passed through the *ios_icc*. The 32-bit or 64-bit address (on Alpha and Integrity server systems) of the buffer available to receive the incoming reply message is placed in offset *ios_icc\$a_reply_buffer* of the *ios_icc*.

reply_buf_len (input)

OpenVMS usage: buffer_size
type: longword (unsigned)
access: read only
mechanism: by value

This parameter is passed through the *ios_icc*. The length (in bytes) of the buffer to receive the reply message. This value specifies the length of the buffer *reply_buf*. This value is placed in offset *ios_icc\$l_txreply_len* of the *ios_icc*.

Description

This service sends a single message over a connection and then waits for a reply. When completion is signaled by calling the AST (if supplied), the data has been delivered to the application at the other end

of the connection and that application has delivered a reply, now present in the reply buffer. The user can reuse the send and reply buffers after completion.

For efficiency reasons, the number of parameters on this routine has been limited to six parameters. Three additional parameters are passed by the *ios_icc* data structure.

Required Access or Privileges

None

Required Quota

BYTLM (Send and Reply buffers)

Related Services

\$ICC_ACCEPT, \$ICC_CLOSE_ASSOC, \$ICC_CONNECT, \$ICC_CONNECTW,
\$ICC_DISCONNECT, \$ICC_DISCONNECTW, \$ICC_OPEN_ASSOC, \$ICC_RECEIVE,
\$ICC_RECEIVEW, \$ICC_REJECT, \$ICC_REPLY, \$ICC_REPLYW, \$ICC_TRANSCEIVEW,
\$ICC_TRANSMIT, \$ICC_TRANSMITW

Condition Values Returned

SS\$_NORMAL

Normal completion.

SS\$_ACCVIO

Access violation on parameter.

SS\$_BADPARAM

Bad parameter value specified.

SS\$_EXBYTLM

Insufficient byte count quota.

SS\$_INSFARG

Too few arguments were supplied.

SS\$_INSFMEM

Insufficient process or system memory to complete the request.

SS\$_IVCHAN

Unknown connection specified or invalid connection handle.

SS\$_IVMODE

Attempted to use a connection from a more privileged access mode than the mode in which it was opened.

SS\$_LINKDISCON

An Incoming disconnect event is in progress.

SS\$_SYNCH

If synchronous mode was requested at connection time, this return value indicates that completion has already occurred and the AST routine, if specified, will not be called.

SS\$_TOO_MANY_ARGS

Too many arguments were specified.

SS\$_WRONGSTATE

Connection is in wrong state for request.

\$ICC_TRANSCEIVEW

Transceive and Wait for Intra-Cluster Communications (ICC) — Sends a single message over a connection and waits for a reply. The `$ICC_TRANSCEIVEW` service completes synchronously; that is, it returns to the caller when the data from the reply is available. For asynchronous completion, use the `$ICC_TRANSCEIVE` service; `$ICC_TRANSCEIVE` returns to the caller when the transmit portion of the transceive request has been queued to the transport layer, but without waiting for notification that the transport layer has released control of the data buffer or for the reply data from the receiving end of the connection. On Alpha and Integrity server systems, this service accepts 64-bit addresses.

Format

```
SYS$ICC_TRANSCEIVEW
    conn_handle , ios_icc , [astadr] , [astprm] , send_buf , send_len
```

C Prototype

```
sys$icc_transceivew
    (unsigned int conn_handle, struct _ios_icc *ios_icc,
     void (*astadr)(__unknown_params), __int64 astprm, char *send_buf,
     unsigned int send_len);
```

\$ICC_TRANSMIT

Transmit for Intra-Cluster Communications (ICC) — Sends a single message over a connection. On Alpha and Integrity server systems, this service accepts 64-bit addresses.

Format

```
SYS$ICC_TRANSMIT
    conn_handle , ios_icc , [astadr] , [astprm] , send_buf , send_len
```

C Prototype

```
sys$icc_transmit
```

```
(unsigned int conn_handle, struct _ios_icc *ios_icc,
void (*astadr)(__unknown_params), __int64 astprm,
char *send_buf, unsigned int send_len);
```

Arguments

conn_handle

OpenVMS usage: connection_id
type: longword (unsigned)
access: read only
mechanism: by value

The handle of the fully established (open) connection to send the data over.

ios_icc

OpenVMS usage: ios_status_block
type: structure IOS_ICC
access: write only
mechanism: by 32-bit or 64-bit reference (Alpha and Integrity servers)

I/O status block:

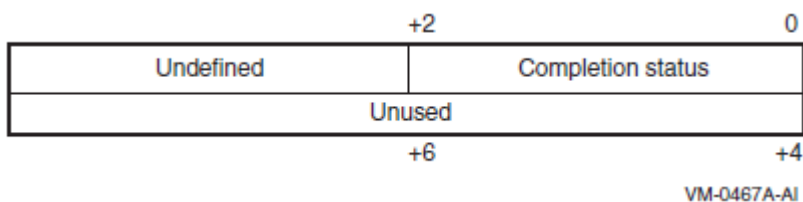

Completion status values:

SS\$_NORMAL, SS\$_EXQUOTA, SS\$_INSFMEM, SS\$_LINKABORT, SS\$_LINKDISCON

astadr

OpenVMS usage: ast_procedure
type: procedure_entry_mask
access: call without stack unwinding
mechanism: by 32-bit or 64-bit linkage reference (Alpha and Integrity servers)

The AST routine to be executed when the operation completes.

astprm

OpenVMS usage: user_arg
type: quadword (unsigned) (Alpha and Integrity servers)
access: read only
mechanism: by 64-bit value (Alpha and Integrity servers)

The parameter to be passed to the AST routine.

send_buf

OpenVMS usage: byte_stream
type: character-coded text string
access: read only
mechanism: by 32-bit or 64-bit reference (Alpha and Integrity servers)

The 32-bit or 64-bit address (on Alpha and Integrity server systems) of the buffer containing the data to be sent. The length of this buffer is specified by the argument *send_len*.

send_len

OpenVMS usage: buffer_length
type: longword (unsigned)
access: read only
mechanism: by value

The length (in bytes) of the data to be sent over the connection. This value specifies the length of the buffer *send_buf*. The maximum transmission size is 1MB.

Description

This service sends a single message over a connection. When completion is signalled by calling the AST (if supplied), the data has been delivered to the communications system, but not necessarily to the system or application at the other end of the connection. After completion, the user can reuse the buffer.

Alternatively, if the synchronous completion option was requested at connection time, the service may return the optional success status, `SS$_SYNCH`. When `SS$_SYNCH` is returned, completion has occurred, and no AST will be delivered.

Required Access or Privileges

None

Required Quota

BYTLM (*send_buf*)

Related Services

`$ICC_ACCEPT`, `$ICC_CLOSE_ASSOC`, `$ICC_CONNECT`, `$ICC_CONNECTW`,
`$ICC_DISCONNECT`, `$ICC_DISCONNECTW`, `$ICC_OPEN_ASSOC`, `$ICC_RECEIVE`,
`$ICC_RECEIVEW`, `$ICC_REJECT`, `$ICC_REPLY`, `$ICC_REPLYW`, `$ICC_TRANSCEIVE`,
`$ICC_TRANSCEIVEW`, `$ICC_TRANSMITW`

Condition Values Returned

`SS$_NORMAL`

Normal completion.

SS\$_ACCVIO

Access violation on parameter.

SS\$_BADPARAM

Bad parameter value specified.

SS\$_EXBYTLM

Insufficient byte count quota.

SS\$_INSFARG

Too few arguments were supplied.

SS\$_INSFMEM

Insufficient process or system memory to complete the request.

SS\$_IVCHAN

Unknown connection specified or invalid connection handle.

SS\$_IVMODE

Attempted to use a connection from a more privileged access mode than the mode in which it was opened.

SS\$_LINKDISCON

An Incoming disconnect event is in progress.

SS\$_SYNCH

If synchronous mode was requested at connection time, this return value indicates that completion has already occurred and the AST routine, if specified, will not be called.

SS\$_TOO_MANY_ARGS

Too many arguments were specified.

SS\$_WRONGSTATE

Connection is in the wrong state for the request.

\$ICC_TRANSMITW

Transmit and Wait for Intra-Cluster Communications (ICC) — Sends a single message over a connection. The \$ICC_TRANSMITW service completes synchronously; that is, it returns to the caller when the underlying transport layer has released use of the Transmit buffer. This does not mean that the data has been received by the partner application. For asynchronous completion, use the \$ICC_TRANSMIT service. The \$ICC_TRANSMIT service returns to the caller as soon as the transmission request has been queued to the transport layer, without waiting for notification that the

transport layer has released control of the data buffer. On Alpha and Integrity server systems, this service accepts 64-bit addresses.

Format

```
SYS$ICC_TRANSMITW
  conn_handle , ios_icc , [astadr] , [astprm] , send_buf , send_len
```

C Prototype

```
sys$icc_transmitw
(unsigned int conn_handle, struct _ios_icc *ios_icc,
 void (*astadr)(__unknown_params), __int64 astprm, char *send_buf,
 unsigned int send_len);
```

\$IDTOASC

Translate Identifier to Identifier Name — Translates the specified identifier value to its identifier name. On Alpha and Integrity server systems, this service accepts 64-bit addresses.

Format

```
SYS$IDTOASC id , [namlen] , [nambuf] , [resid] , [attrib] , [contxt]
```

C Prototype

```
int sys$idtoasc
(unsigned int id, unsigned short int *namlen, void *nambuf,
 unsigned int *resid, unsigned int *attrib, unsigned int *contxt);
```

Arguments

id

OpenVMS usage: rights_id
type: longword (unsigned)
access: read only
mechanism: by value

Binary identifier value translated by \$IDTOASC. The *id* argument is a longword containing the binary value of the identifier. To determine the identifier names of all identifiers in the rights database, you specify *id* as -1 and call \$IDTOASC repeatedly until it returns the status code SS\$_NOSUCHID. The identifiers are returned in alphabetical order.

namlen

OpenVMS usage: word_unsigned
type: word (unsigned)
access: write only
mechanism: by 32- or 64-bit reference (Alpha and Integrity servers)

Number of characters in the identifier name translated by \$IDTOASC. The *namlen* argument is the 32- or 64-bit address (on Alpha and Integrity server systems) of a word containing the length of the identifier name written to *nambuf*.

nambuf

OpenVMS usage: char_string
 type: character-coded text string
 access: write only
 mechanism: by 32- or 64-bit descriptor–fixed-length string descriptor (Alpha and Integrity servers)

Identifier name text string returned when \$IDTOASC completes the translation. The *nambuf* argument is the 32- or 64-bit address (on Alpha and Integrity server systems) of a descriptor pointing to the buffer in which the identifier name is written.

resid

OpenVMS usage: rights_id
 type: longword (unsigned)
 access: write only
 mechanism: by 32- or 64-bit reference (Alpha and Integrity servers)

Identifier value of the identifier name returned in *nambuf*. The *resid* argument is the 32- or 64-bit address (on Alpha and Integrity server systems) of a longword containing the 32-bit code of the identifier.

attrib

OpenVMS usage: mask_longword
 type: longword (unsigned)
 access: write only
 mechanism: by 32- or 64-bit reference (Alpha and Integrity servers)

Mask of attributes associated with the identifier returned in *resid*. The *attrib* argument is the 32- or 64-bit address (on Alpha and Integrity server systems) of a longword containing the attribute mask.

Symbol values are offsets to the bits within the longword. You can also obtain the values as masks with the appropriate bit set using the prefix KGB\$M rather than KGB\$V. The following symbols for each bit position are defined in the system macro library (\$KGBDEF):

Bit Position	Meaning When Set
KGB\$V_DYNAMIC	Allows holders of the identifier to remove it from or add it to the process rights list using the DCL command SET RIGHTS_LIST.
KGB\$V_NAME_HIDDEN	Allows holders of an identifier to have it translated – either from binary to ASCII or vice versa – but prevents unauthorized users from translating the identifier.
KGB\$V_NOACCESS	Makes any access rights of the identifier null and void. This attribute is intended as a modifier for a resource identifier or the Subsystem attribute.

Bit Position	Meaning When Set
KGB\$V_RESOURCE	Allows holders of an identifier to charge disk space to the identifier. It is used only for file objects.
KGB\$V_SUBSYSTEM	Allows holders of the identifier to create and maintain protected subsystems by assigning the Subsystem ACE to the application images in the subsystem.

ctxt

OpenVMS usage: ctxt
type: longword (unsigned)
access: modify
mechanism: by 32- or 64-bit reference (Alpha and Integrity servers)

Context value used when repeatedly calling \$IDTOASC. The *ctxt* argument is the 32- or 64-bit address (on Alpha and Integrity server systems) of a longword used while \$IDTOASC searches for all identifiers. The context value must be initialized to the value 0, and the resulting context of each call to \$IDTOASC must be presented to each subsequent call. After *ctxt* is passed to \$IDTOASC, you must not modify its value.

Description

The Translate Identifier to Identifier Name service translates the specified binary identifier value to an identifier name. While the primary purpose of this service is to translate the specified identifier to its name, you can also use it to find all identifiers in the rights database. Owner or read access to the rights database is required. To determine all the identifiers, call \$IDTOASC repeatedly until it returns the status code SS\$_NOSUCHID. When SS\$_NOSUCHID is returned, \$IDTOASC has returned all the identifiers, cleared the context value, and deallocated the record stream.

If you complete your calls to \$IDTOASC before SS\$_NOSUCHID is returned, use \$FINISH_RDB to clear the context value and deallocate the record stream.

When you use wildcards with this service, the records are returned in identifier name order.

Required Access or Privileges

None, unless the *id* argument is NAME_HIDDEN, in which case you must hold the identifier or have read access to the rights list.

Required Quota

None

Related Services

\$ADD HOLDER, \$ADD_IDENT, \$ASCTOID, \$CHECK_ACCESS, \$CHKPRO, \$CREATE_RDB, \$ERAPAT, \$FIND_HELD, \$FIND HOLDER, \$FINISH_RDB, \$FORMAT_ACL, \$FORMAT_AUDIT, \$GET_SECURITY, \$GRANTID, \$HASH_PASSWORD, \$MOD HOLDER, \$MOD_IDENT, \$MTACCESS, \$PARSE_ACL, \$REM HOLDER, \$REM_IDENT, \$REVOKEID, \$SET_SECURITY

Condition Values Returned

SS\$_NORMAL

The service completed successfully.

SS\$_ACCVIO

The *namlen*, *nambuf*, *resid*, *attrib*, or *contxt* argument cannot be written by the caller.

SS\$_INSFMEM

The process dynamic memory is insufficient for opening the rights database.

SS\$_IVCHAN

The contents of the context longword are not valid.

SS\$_IIDENT

The specified identifier is of invalid format.

SS\$_NOIOCHAN

No more rights database context streams are available.

SS\$_NORIGHTSDB

The rights database does not exist.

SS\$_NOSUCHID

The specified identifier name does not exist in the rights database, or the entire rights database has been searched if the ID is -1.

Because the rights database is an indexed file that you access with OpenVMS RMS, this service can also return RMS status codes associated with operations on indexed files. For descriptions of these status codes, refer to the *VSI OpenVMS Record Management Services Reference Manual*.

\$IEEE_SET_FP_CONTROL (Alpha and Integrity servers)

Set IEEE Floating-Point Control Register — On Alpha and Integrity server systems, modifies IEEE floating-point state and, optionally, returns the previous value. The service provides the mechanism to set the specified state bits, to clear the specified state bits, and to swap one set of state bits for another.

Format

```
SYS$IEEE_SET_FP_CONTROL [clrmsk] , [setmsk] , [prvmsk]
```

C Prototype

```
int sys$ieee_set_fp_control  
    (struct _ieee *clrmsk, struct _ieee *setmsk, struct _ieee *prvmsk);
```

Arguments

clrmsk

OpenVMS usage: mask_quadword
 type: quadword (unsigned)
 access: read only
 mechanism: by reference

Address of a quadword bit mask to be cleared in the IEEE floating-point control register.

The \$IEEEDEF macro defines symbols for the floating-point control register. Table 3 shows the symbols, their corresponding masks, and their meaning.

Table 3. Format of the IEEE Floating-Point Control Register (Alpha and Integrity servers)

Symbol	Mask	Meaning
IEEE\$M_TRAP_ENABLE_INV	2	Enable invalid operation exception
IEEE\$M_TRAP_ENABLE_DZE	4	Enable divide by 0 exception
IEEE\$M_TRAP_ENABLE_OVF	8	Enable overflow exception
IEEE\$M_TRAP_ENABLE_UNF	10	Enable underflow exception
IEEE\$M_TRAP_ENABLE_INE	20	Enable inexact exception
IEEE\$M_TRAP_ENABLE_DNOE	40	Enable denormal operand exception
IEEE\$M_MAP_DNZ	2000	Denormal operands are mapped to 0.0
IEEE\$M_MAP_UMZ	4000	Underflow results are mapped to 0.0
IEEE\$M_INHERIT	8000	Inherit FP state on thread create
IEEE\$M_STATUS_INV	20000	Invalid operation
IEEE\$M_STATUS_DZE	40000	Divide by 0
IEEE\$M_STATUS_OVF	80000	Overflow
IEEE\$M_STATUS_UNF	100000	Underflow
IEEE\$M_STATUS_INE	200000	Inexact
IEEE\$M_STATUS_DNO	400000	Denormal operand

setmsk

OpenVMS usage: mask_quadword
 type: quadword (unsigned)
 access: read only
 mechanism: by reference

Address of a quadword bit mask to be set in the IEEE floating-point control register.

Table 3 shows the format of the IEEE floating-point control register.

prvmsk

OpenVMS usage: mask_quadword
 type: quadword (unsigned)
 access: write only
 mechanism: by reference

Address of a quadword to receive the previous value of the IEEE floating-point control register.

Description

The Set IEEE Floating-Point Control Register service updates the IEEE floating-point control register, maintained by the operating system, with the values supplied by the calling program.

The following steps are used to update the register:

1. If the *prvmsk* argument is specified, \$IEEE_SET_FP_CONTROL first reads the previous value of the IEEE floating-point control register.
2. If the *clrmsk* argument is specified, \$IEEE_SET_FP_CONTROL then clears the specified bit masks in the *clrmsk* argument.
3. If the *setmsk* argument is specified, \$IEEE_SET_FP_CONTROL then sets the specified bit masks in the *setmsk* argument.

A program can swap the IEEE floating-point control register (that is, save the old value and specify a new value) by specifying the following:

- The *clrmsk* argument with the address of a quadword of all 1s
- The *setmsk* argument with the address of a quadword that holds the new register value
- The *prvmsk* argument with the address of a quadword to save the old register value

On Integrity server systems, the initial state value and the scope of the modified state values differ depending on the location of the call to this routine, as shown in the following table.

Location of Call	State Value	Scope of New State Value
Mainline	Determined by the compiler switches used when compiling the modules.	Change is in effect until this service is called again, with the exception of ASTs (see below).
Condition handler	The same as the state in effect when the condition occurs, unless the setting was changed by a previous condition handler.	Change is in effect until all remaining condition handlers have been called or this service is called again.
AST routine	Determined by the compiler switches used when compiling the modules, regardless of the state value in effect when the AST was triggered.	Change is in effect only until the AST completes or this service is called again.

On Alpha systems, calling this routine changes the setting for ASTs as well as the mainline program.

Required Access or Privilege

None

Required Quota

None

Related Services

\$IEEE_SET_PRECISION_MODE
\$IEEE_SET_ROUNDING_MODE

Condition Values Returned

SS\$_NORMAL

The service completed successfully.

SS\$_ACCVIO

The specified argument cannot be read or cannot be written.

\$IEEE_SET_PRECISION_MODE (Integrity servers Only)

Set IEEE Precision Mode — On Integrity server systems, modifies the IEEE precision mode and, optionally, returns the previous value.

Format

```
SYSS$IEEE_SET_PRECISION_MODE new_value , [*prev_value]
```

C Prototype

```
int sys$ieee_set_precision_mode (int new_value, int *prev_value);
```

Arguments

new_value

OpenVMS usage: IEEE precision mode
type: longword (unsigned)
access: read only
mechanism: by value

The new value can be one of the following:

Symbol	Value	Meaning
IEEE\$C_PM_NO_CHANGE	-1	No change. Just get previous value
IEEE\$C_PM_SINGLE	0	Single Precision
IEEE\$C_PM_DOUBLE	2	Double Precision

Symbol	Value	Meaning
IEEE\$C_PM_DOUBLE_EXTENDED	3	Double-Extended Precision

prev_value

OpenVMS usage: IEEE precision mode
type: longword (unsigned)
access: write only
mechanism: by reference

The previous value is a pointer to a return value that can be one of the last three items from the table showing new values.

Description

The initial precision mode and the scope of the modified precision mode differ depending on the location of the call to this routine, as shown in the following table.

Location of Call	Initial Precision Mode	Scope of New Precision Mode
Mainline	Determined by the compiler switches used when compiling the modules.	Change is in effect until this service is called again with the exception of ASTs (see below).
Condition handler	The same as the precision mode in effect when the condition occurs, unless the setting was changed by a previous condition handler.	Change is in effect until all remaining condition handlers have been called or this service is called again.
AST routine	Determined by the compiler switches used when compiling the modules, regardless of the precision in effect when the AST was triggered.	Change is in effect only until the AST completes or this service is called again.

Required Access or Privileges

None

Required Quotas

None

Related Services

\$IEEE_SET_FP_CONTROL
\$IEEE_SET_ROUNDING_MODE

\$IEEE_SET_ROUNDING_MODE (Integrity servers Only)

Set IEEE Rounding Mode — On Integrity server systems, modifies the IEEE rounding mode and, optionally, returns the previous value.

Format

```
SYSS$IEEE_SET_ROUNDING_MODE new_value , [*prev_value]
```

C Prototype

```
int sys$ieee_set_rounding_mode (int new_value, int *prev_value);,
```

Arguments

new_value

OpenVMS usage: IEEE rounding mode
 type: longword (unsigned)
 access: read only
 mechanism: by value

The new value can be one of the following:

Symbol	Value	Meaning
IEEE\$C_RM_NO_CHANGE	-1	No change. Just get previous value
IEEE\$C_RM_NEAREST	0	Nearest (or even)
IEEE\$C_RM_DOWN	1	-Infinity (down)
IEEE\$C_RM_UP	2	+Infinity (up)
IEEE\$C_RM_TRUNCATE	3	Zero (truncate/chop)

prev_value

OpenVMS usage: IEEE rounding mode
 type: longword (unsigned)
 access: write only
 mechanism: by reference

The previous value is a pointer to a return value that can be one of the last four items from the table showing new values.

Description

The initial rounding mode and the scope of the modified rounding mode differ depending on the location of the call to this routine, as shown in the following table.

Location of Call	Initial Rounding Mode	Scope of New Rounding Mode
Mainline	Determined by the compiler switches used when compiling the modules.	Change is in effect until this service is called again, with the exception of ASTs (see below).
Condition handler	The same as the rounding mode in effect when the condition occurs, unless	Change is in effect until all remaining condition handlers have been called or this service is called again.

Location of Call	Initial Rounding Mode	Scope of New Rounding Mode
	the setting was changed by a previous condition handler.	
AST routine	Determined by the compiler switches used when compiling the modules, regardless of the rounding in effect when the AST was triggered.	Change is in effect only until the AST completes or this service is called again.

Required Access or Privileges

None

Required Quota

None

Related Services

\$IEEE_SET_FP_CONTROL
\$IEEE_SET_PRECISION_MODE

\$INIT_SYS_ALIGN_FAULT_REPORT (Alpha and Integrity servers)

Initialize System Alignment Fault Reporting — On Alpha and Integrity server systems, initializes system process alignment fault reporting. This service accepts 64-bit addresses.

Format

```
SYSS$INIT_SYS_ALIGN_FAULT_REPORT match_table ,buffer_size ,flags
```

C Prototype

```
int sys$init_sys_align_fault_report
(void *match_table, int buffer_size, unsigned int flags);
```

Arguments

match_table

OpenVMS usage: address
type: longword (unsigned)
access: read
mechanism: by 32-bit or 64-bit reference

Describes the system fault match table. The *match_table* argument is the 32-bit or 64-bit virtual address of an array of longwords describing the system fault match table. The first longword is the number of match entries; the remaining longwords are the match entries.

The match table is used to restrict the number of alignment faults reported. Each entry in the table is a bit mask divided into three groups: mode bits, program counter (PC) space bits, and virtual address (VA) space bits.

The following table lists the symbols that can be used to define these bits.

Bit Type	Symbols	
Mode bits	AME\$M_KERNEL_MODE	Kernel mode
	AME\$M_EXEC_MODE	Executive mode
	AME\$M_SUPER_MODE	Supervisor mode
	AME\$M_USER_MODE	User mode
Program counter bits	AME\$M_USER_PC	PC in User space
	AME\$M_SYSTEM_PC	PC in System space
Virtual address bits	AME\$M_SYSTEM_VA	VA in System space
	AME\$M_USER_VA_P0	VA in User P0 space
	AME\$M_USER_VA_P1	VA in User P1 space
	AME\$M_USER_VA_P2	VA in User P2 space

The following diagram illustrates the data structure of the match table.

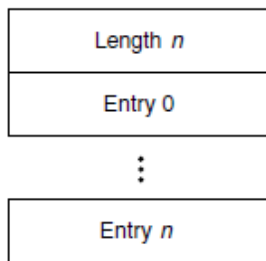

ZK-4981A-GE

When an alignment fault occurs, a fault bit mask is created with one bit set in each group. The alignment fault handler then compares this fault bit mask against each entry in the match table. If the fault bit mask is a subset of an entry in the match table, the fault is reported.

buffer_size

OpenVMS usage: byte count
 type: longword (signed)
 access: read
 mechanism: by value

The number of bytes to allocate, from nonpaged pool, to save the alignment fault data. The buffer you allocate must be sufficient to accommodate one data item of the size specified in the *flags* argument.

flags

OpenVMS usage: mask_longword
 type: longword (unsigned)
 access: read only

mechanism: by value

Flag bit mask specifying options for the \$GET_SYS_ALIGN_FAULT_DATA operation.

If the *flags* argument is 0, data items of size AFR\$K_VMS_LENGTH will be returned. If the *flags* argument is AFR\$M_USER_INFO, the user name and image name are added to each data item and they are returned in a buffer of length AFR\$K_EXTENDED_LENGTH. If the user name and image name are not available, an empty string is returned in the data item.

Description

The Initialize System Alignment Fault Reporting service initializes system alignment fault reporting.

System alignment faults must be written to a buffer. The following diagram illustrates the format in which system alignment fault data is saved in the buffer.

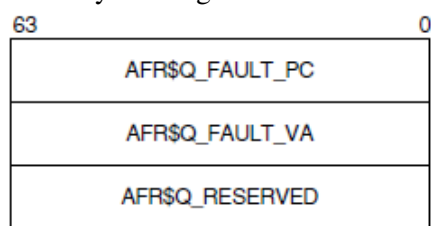

ZK-4982A-GE

Only one user on a system can initialize system alignment fault reporting at any time. Subsequent calls will return SS\$_AFR_ENABLED.

System alignment fault reporting is disabled when the program that called the service completes.

Required Access or Privileges

CMKRNL privilege is required.

Required Quota

None

Related Services

\$GET_ALIGN_FAULT_DATA, \$GET_SYS_ALIGN_FAULT_DATA,
 \$PERM_DIS_ALIGN_FAULT_REPORT, \$PERM_REPORT_ALIGN_FAULT,
 \$START_ALIGN_FAULT_REPORT, \$STOP_ALIGN_FAULT_REPORT,
 \$STOP_SYS_ALIGN_FAULT_REPORT

Condition Values Returned

SS\$_NORMAL

The service completed successfully.

SS\$_ACCVIO

The match table is not read accessible.

SS\$_AFR_ENABLED

The service was already called.

SS\$_BADPARAM

The *buffer_size* argument is less than the minimum size required. If the *flags* argument is 0, AFR\$K_VMS_LENGTH + 32 is required. If the *flags* argument is 1, AFR\$K_EXTENDED_LENGTH + 32 is required.

SS\$_NOPRIV

The caller does not have CMKRNL privilege.

\$INIT_VOL

Initialize Volume — Formats a disk or magnetic tape volume and writes a label on the volume. At the end of initialization, the disk is empty except for the system files containing the structure information. All former contents of the volume are lost.

Format

```
SYS$INIT_VOL devnam, volnam [,itmlst]
```

C Prototype

```
int sys$init_vol (void *devnam, void *volnam, void *itmlst);
```

Arguments

devnam

OpenVMS usage: char_string
type: character string
access: read only
mechanism: by descriptor

Name of the device on which the volume is physically mounted. The descriptor must point to the device name, a character string of 1 to 64 characters. The device name can be a physical device name or a logical name; if it is a logical name, it must translate to a physical name.

The device does not have to be currently allocated; however, allocating the device before initializing it is recommended.

volnam

OpenVMS usage: char_string
type: character string
access: read only
mechanism: by descriptor

Identification to be encoded on the volume. The descriptor must point to the volume name, a character string of 1 to 12 characters. For a disk volume name, you can specify a maximum of 12 ANSI characters; for a magnetic tape volume name, you can specify a maximum of 6 ANSI “a” characters. Any valid ANSI “a” characters can be used; these include numbers, uppercase letters, and any one of the following nonalphanumeric characters:

! " % ' () * + , - . / : ; < = >

VSI strongly recommends that a disk volume name consist of only alphanumeric characters, dollar signs (\$), underscores (_), and hyphens (-).

itmlst

OpenVMS usage: item_list_3
 type: longword (unsigned)
 access: read only
 mechanism: by reference

Item list specifying options that can be used when initializing the volume. The *itmlst* argument is the address of a list of item descriptors, each of which describes one option. The list of item descriptors is terminated by a longword of 0.

The following diagram depicts the format of a single item descriptor.

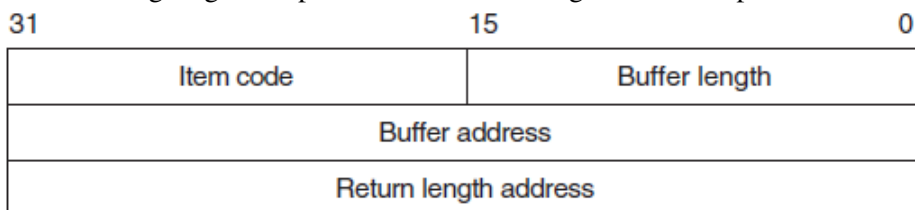

ZK-5186A-GE

The following table defines the item descriptor fields.

Descriptor Field	Definition						
Buffer length	A word specifying the length (in bytes) of the buffer that supplies the information \$INIT_VOL needs to process the specific item code. The length of the buffer needed depends on the item code specified in the item descriptor.						
Item code	A word containing an option for the initialize operation. These codes are defined by the \$INITDEF macro. There are three types of item codes: <table border="1" style="width: 100%; border-collapse: collapse;"> <tr> <td style="width: 30%;">Boolean item code</td> <td>Boolean item codes specify a true or false value. The form INIT\$_code specifies a true value and the form INIT\$_NO_code specifies a false value. For Boolean item codes, the buffer length and buffer address fields of the item descriptor must be 0.</td> </tr> <tr> <td>Symbolic value item code</td> <td>Symbolic value item codes specify one of a specified range of possible choices. The buffer length and buffer address fields of the item descriptor must be 0.</td> </tr> <tr> <td>Input value item code</td> <td>Input value item codes specify a value to be used by \$INIT_VOL. The buffer length and buffer address fields of the item descriptor must be nonzero.</td> </tr> </table>	Boolean item code	Boolean item codes specify a true or false value. The form INIT\$_code specifies a true value and the form INIT\$_NO_code specifies a false value. For Boolean item codes, the buffer length and buffer address fields of the item descriptor must be 0.	Symbolic value item code	Symbolic value item codes specify one of a specified range of possible choices. The buffer length and buffer address fields of the item descriptor must be 0.	Input value item code	Input value item codes specify a value to be used by \$INIT_VOL. The buffer length and buffer address fields of the item descriptor must be nonzero.
Boolean item code	Boolean item codes specify a true or false value. The form INIT\$_code specifies a true value and the form INIT\$_NO_code specifies a false value. For Boolean item codes, the buffer length and buffer address fields of the item descriptor must be 0.						
Symbolic value item code	Symbolic value item codes specify one of a specified range of possible choices. The buffer length and buffer address fields of the item descriptor must be 0.						
Input value item code	Input value item codes specify a value to be used by \$INIT_VOL. The buffer length and buffer address fields of the item descriptor must be nonzero.						

Descriptor Field	Definition
Buffer address	A longword containing the address of the buffer that supplies information to \$INIT_VOL.
Return length address	This field is not used.

Item Codes

INIT\$_ACCESSED

An input item code that specifies the number of directories allowed in system space on the volume.

You must specify an integer between 0 and 255 in the input buffer. The default value is 3.

The INIT\$_ACCESSED item code applies only to Files-11 On-Disk Structure Level 1 disks.

INIT\$_BADBLOCKS_LBN

An input item code that enables \$INIT_VOL to mark bad blocks on the volume; no data is written to those faulty areas. INIT\$_BADBLOCKS_LBN specifies faulty areas on the volume by logical block number and block count.

The buffer from which \$INIT_VOL reads the option information contains an array of quadwords containing information in the following format.

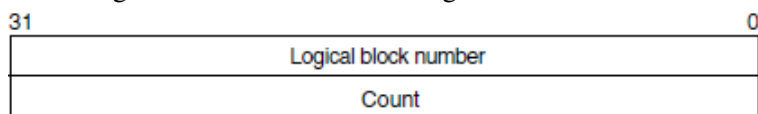

ZK-1590A-GE

The following table describes the information to be specified for INIT\$_BADBLOCKS_LBN.

Field	Symbol Name	Description
Logical block number	INIT\$_L_BADBLOCKS_LBN	Specifies the logical block number of the first block to be marked as allocated.
Count	INIT\$_L_BADBLOCKS_COUNT	Specifies the number of blocks to be allocated. This range begins with the first block, as specified in INIT\$_L_BADBLOCKS_LBN.

For example, if the input buffer contains the values 5 and 3, INIT_VOL starts at logical block number 5 and allocates 3 blocks.

The number of entries in the buffer is determined by the buffer length field in the item descriptor.

All media supplied by HP and supported on the operating system, except disks and TU58 cartridges, are factory formatted and contain bad block data. The Bad Block Locator utility (BAD) or the diagnostic formatter EVRAC can be used to refresh the bad block data or to construct it for the disks and TU58 cartridges. The INIT\$_BADBLOCKS_LBN item code is necessary only to enter bad blocks that are not identified in the volume's bad block data. For more information, see the *OpenVMS Bad Block Locator Utility Manual*.

The INIT\$_BADBLOCKS_LBN item code applies only to disks.

INIT\$_BADBLOCKS_SEC

An input item code that specifies faulty areas on the volume by sector, track, cylinder, and block count. \$INIT_VOL marks the bad blocks as allocated; no data is written to them.

The input buffer must contain an array of octawords containing information in the following format.

31	Sector	0
	Count	
	Track	
	Cylinder	

ZK-1591A-GE

The following table describes the information to be specified for INIT\$_BADBLOCKS_SEC.

Field	Symbol Name	Description
Sector	INIT\$_L_BADBLOCKS_SECTOR	Specifies the sector number of the first block to be marked as allocated.
Count	INIT\$_L_BADBLOCKS_COUNT	Specifies the number of blocks to be allocated.
Track	INIT\$_L_BADBLOCKS_TRACK	Specifies the track number of the first block to be marked as allocated.
Cylinder	INIT\$_L_BADBLOCKS_CYLINDER	Specifies the cylinder number of the first block to be marked as allocated.

For example, if the input buffer contains the values 12, 3, 1, and 2, INIT_VOL starts at sector 12, track 1, cylinder 2, and allocates 3 blocks.

The number of entries in the buffer is determined by the buffer length field in the item descriptor.

All media supplied by HP and supported on the operating system, except disks and TU58 cartridges, are factory formatted and contain bad block data. The Bad Block Locator utility (BAD) or the diagnostic formatter EVRAC can be used to refresh the bad block data or to construct it for the disks and TU58 cartridges. The INIT\$_BADBLOCKS_SEC item code is necessary only to enter bad blocks that are not identified in the volume's bad block data. For more information, see the *OpenVMS Bad Block Locator Utility Manual*.

The INIT\$_BADBLOCKS_SEC item code applies only to disks.

INIT\$_CLUSTERSIZE

An input item code that specifies the minimum allocation unit in blocks. The input buffer must contain a longword value. The maximum size that can be specified for a volume is one-hundredth the size of the volume; the minimum size is calculated with the following formula:

$$\text{volume size in blocks} / (255 * 4096)$$

The INIT\$_CLUSTERSIZE item code applies only to Files-11 On-Disk Structure Level 2 disks (for Files-11 On-Disk Structure Level 1 disks, the cluster size is 1). For Files-11 On-Disk Structure Level 2 disks, the cluster size default depends on the disk capacity.

- Disks that are 50,000 blocks or larger have a default cluster size of 16.
- Disks smaller than 50,000 blocks have a default value of 1.

Note

This item code applies to ODS-5 disks as well as to ODS-2 disks. For more information, see the INITIALIZE command in the *VSI OpenVMS DCL Dictionary*.

INIT\$_COMPACTION**INIT\$_NO_COMPACTION—Default**

A Boolean item code that specifies whether data compaction should be performed when writing the volume.

The INIT\$_COMPACTION item code applies only to TA90 drives.

INIT\$_DENSITY

A symbolic item code that specifies the density value for magnetic tapes and diskettes.

For magnetic tape volumes, the INIT\$_DENSITY item code specifies the density.

The DENSITY item code is dependent on the type of tape device. If a tape device is seen as capable of using the MT3 density codes the buffer for MNT\$_DENSITY item code must contain a longword with one of the MT3 codes, as defined in SYS\$LIBRARY:STARLET (MT3\$K_TK50, MT3\$K_3480, M53\$K_DSDLT, MT3\$K_AIT2 and so on). Refer to the MT3_SUPPORTED argument for \$GETDVI.

If the device does not support MT3 densities, the buffer specifies the density in bytes per inch (bpi) at which the magnetic tape is written. The following are possible symbolic values for tapes:

- INIT\$K_DENSITY_800_BPI
- INIT\$K_DENSITY_1600_BPI
- INIT\$K_DENSITY_6250_BPI

The specified density value must be supported by the drive. If you do not specify a density item code for a blank magnetic tape, the system uses a default density of the highest value allowed by the tape drive. If the drive allows 6250, 1600, and 800 bpi operation, the default density is 6250. If the drive allows only 1600 and 800 bpi operation, the default density is 1600. If you do not specify a density item code for a magnetic tape that has been previously written, the system uses the previously set volume density.

For diskettes, the INIT\$_DENSITY item code specifies how the diskette is to be formatted. Possible symbolic values for diskettes are as follows:

- INIT\$K_DENSITY_SINGLE_DISK
- INIT\$K_DENSITY_DOUBLE_DISK
- INIT\$K_DENSITY_DD_DISK
- INIT\$K_DENSITY_HD_DISK

For disk volumes that are to be initialized on RX02, RX23, or RX33 diskette drives, the following values specify how the disk is to be formatted:

- INIT\$K_DENSITY_SINGLE_DISK

- INIT\$K_DENSITY_DOUBLE_DISK
- INIT\$K_DENSITY_DD_DISK
- INIT\$K_DENSITY_HD_DISK

Diskettes are initialized as follows:

- RX23 diskettes – DD or HD density
- RX33 diskettes – double density only
- RX02 dual-density diskette drives – single or double density

If you do not specify a density item code for a disk, the system leaves the volume at the density at which it was last formatted. RX02 disks purchased from HP are formatted in single density.

INIT\$_DIRECTORIES

An input item code that specifies the number of entries to preallocate for user directories. The input buffer must contain a longword value in the range of 16 to 16000. The default value is 16.

The INIT\$_DIRECTORIES item code applies only to disks.

INIT\$_ERASE

INIT\$_NO_ERASE—Default

A Boolean item code that specifies whether deleted data should be physically destroyed by performing the data security erase (DSE) operation on the volume before initializing it. The INIT\$_ERASE item code applies to the following devices:

- ODS-2 disk volumes
- ANSI magnetic tape volumes on magnetic tape devices that support the hardware erase function, for example, TU78 and MSCP magnetic tapes

For disk devices, this item code sets the ERASE volume attribute, causing each file on the volume to be erased when it is deleted.

INIT\$_ERASE_ON_DELETE

A Boolean item code that sets the HM2\$V_ERASE bit. The volume is marked so that when files are deleted, the blocks that they formerly occupied are erased. See the DCL command SET VOLUME/ERASE for more information.

INIT\$_ERASE_ON_INIT

A Boolean item code that specifies whether to perform the data security erase (DSE) operation immediately.

INIT\$_EXTENSION

An input item code that specifies, by the number of blocks, the default extension size for all files on the volume. The extension default is used when a file increases to a size greater than its initial default allocation during an update. For Files-11 On-Disk Structure Level 2 disks, the buffer must contain a longword value in the range 0 to 65535. For Files-11 On-Disk Structure Level 1 disks, the input buffer

must contain a longword value in the range of 0 to 255. The default value is 5 for both Structure Level 1 and Structure Level 2 disks.

The default extension set by this item code is used only if the following conditions are in effect:

- No default extension for the file has been set
- No default extension for the process has been set using the SET RMS command

Note

This item code applies to ODS-5 disks as well as to ODS-2 disks. For more information, see the INITIALIZE command in the *VSI OpenVMS DCL Dictionary*.

INIT\$_FPROT

An input item code that specifies the default protection applied to all files on the volume. The input buffer must contain a longword protection mask that contains four 4-bit fields. Each field grants or denies read, write, create, and delete access to a category of users. Cleared bits grant access; set bits deny access.

The following diagram depicts the structure of the protection mask on systems.

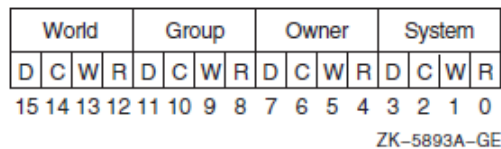

The INIT\$_FPROT item code applies only to Files-11 On-Disk Structure Level 1 disks and is ignored if it is used on an OpenVMS system. OpenVMS systems use the default file extension set by the DCL command SET PROTECTION/DEFAULT.

INIT\$_HEADERS

An input item code that specifies the number of file headers to be allocated for the index file. The input buffer must contain a longword value within the range of 16 to the value set by the INIT\$_MAXFILES item code. The default value is 16.

The INIT\$_HEADERS item code applies only to disks.

INIT\$_GPT—Default on Integrity servers

INIT\$_NO_GPT—Default on Alpha

A Boolean item code that specifies whether or not to create a Global Universal ID (GUID) Partition Table (GPT) structure.

INIT\$_HIGHWATER—Default

INIT\$_NO_HIGHWATER

A Boolean item code that sets the file highwater mark (FHM) volume attribute, which guarantees that users cannot read data that they have not written.

INIT\$_NO_HIGHWATER disables FHM for a volume.

The INIT\$_HIGHWATER and INIT\$_NO_HIGHWATER item codes apply only to Files-11 On-Disk Structure Level 2 disks.

INIT\$_HOMEBLOCKS

Specifies where the volume's homeblock and spare copy of the homeblock are placed on disk. This item code applies to Files-11 ODS-2 volumes, and can have the following values:

- **INIT\$_K_HOMEBLOCKS_GEOMETRY**

Causes the homeblocks to be placed at separate locations on disk, to protect against failure of a disk block. Placement depends on the reported geometry of the disk.

- **INIT\$_K_HOMEBLOCKS_FIXED**

Causes the homeblocks to be placed at separate fixed locations on the disk; this is the default. Placement is independent of the reported geometry of the disk. This caters for disks that report different geometries according to the type of controller to which they are attached.

- **INIT\$_K_HOMEBLOCKS_CONTIGUOUS**

Causes the homeblocks to be placed contiguously at the start of the disk. This allows container file systems to maximize the amount of contiguous space on the disk, when used with the **INIT\$_INDEX_BEGINNING** item code.

Note

This item code applies to ODS-5 disks as well as to ODS-2 disks. For more information, see the **INITIALIZE** command in the *VSI OpenVMS DCL Dictionary*.

INIT\$_INDEX_BEGINNING

A symbolic item code that places the index file for the volume's directory structure at the beginning of the volume. By default, the index is placed in the middle of the volume.

When issuing calls to **\$INIT_VOL**, using this item code in conjunction with **INIT\$_INDEX_BLOCK** results in an error. If you specify both item codes from DCL, **INIT\$_INDEX_BLOCK** takes precedence.

This item code applies only to disks.

INIT\$_INDEX_BLOCK

An input item code that specifies the location of the index file for the volume's directory structure by logical block number. The input buffer must contain a longword value specifying the logical block number of the first block of the index file. By default, the index is placed in the middle of the volume.

When issuing calls to **\$INIT_VOL**, using this item code with **INIT\$_INDEX_BEGINNING**, **INIT\$_INDEX_MIDDLE**, or **INIT\$_INDEX_END** results in an error. From DCL, if you specify **INIT\$_INDEX_BLOCK** with **INIT\$_INDEX_BEGINNING**, **INIT\$_INDEX_MIDDLE**, or **INIT\$_INDEX_END**, then **INIT\$_INDEX_BLOCK** takes precedence.

The **INIT\$_INDEX_BLOCK** item code applies only to disks.

INIT\$_INDEX_END

A symbolic item code that places the index file for the volume's directory structure at the end of the volume. The default is to place the index in the middle of the volume.

When issuing calls to \$INIT_VOL, using this item code with INIT\$_INDEX_BLOCK results in an error. If you specify both item codes from DCL, INIT\$_INDEX_BLOCK takes precedence.

This item code applies only to disks.

INIT\$_INDEX_MIDDLE

A symbolic item code that places the index file for the volume's directory structure in the middle of the volume. This is the default location for the index.

When issuing calls to \$INIT_VOL, using this item code with INIT\$_INDEX_BLOCK results in an error. If you specify both item codes from DCL, INIT\$_INDEX_BLOCK takes precedence.

This item code applies only to disks.

INIT\$_INTERCHANGE

An input item code that specifies that the magnetic tape ANSI VOL1 volume label is to be used for interchange in a heterogeneous vendor environment. On OpenVMS, this item code overrides creation of the ANSI VOL2 volume label, which contains security attributes specific to OpenVMS systems.

For more information about the INIT\$_INTERCHANGE item code and about magnetic tape labeling and tape interchange, see the *VSI OpenVMS System Manager's Manual*.

INIT\$_LABEL_ACCESS

An input item code that specifies the character to be written in the volume accessibility field of the ANSI volume label VOL1 on an ANSI magnetic tape. Any valid ANSI "a" characters can be used; these include numbers, uppercase letters, and any one of the following nonalphanumeric characters:

! " % ' () * + , - . / : ; < = >

By default, the operating system provides a routine SYS\$MTACCESS that checks this field in the following manner:

- If the magnetic tape was created on a version of the operating system that conforms to Version 3 of ANSI, this item code is used to override any character except an ASCII space.
- If the magnetic tape conforms to an ANSI standard that is later than Version 3, this item code is used to override any character except an ASCII 1 character.

INIT\$_LABEL_VOLO

An input item code that specifies the text that is written in the owner identifier field of the ANSI volume label VOL1 on an ANSI magnetic tape. The owner identifier field can contain up to 14 valid ANSI "a" characters.

INIT\$_MAXFILES

An input item code that restricts the maximum number of files that the volume can contain. The input buffer must contain a longword value between 0 and a value determined by the following calculation:

```
volume size in blocks/cluster factor + 1
```

Once initialized, the maximum number of files can be increased only by reinitializing the volume.

The default maximum number of files is calculated as follows:

volume size in blocks/(cluster factor + 1) * 2

The INIT\$_MAXFILES item code applies only to disks.

Note

This item code applies to ODS-5 disks as well as to ODS-2 disks. For more information, see the INITIALIZE command in the *VSI OpenVMS DCL Dictionary*.

INIT\$_OVR_ACCESS

INIT\$_NO_OVR_ACCESS—Default

A Boolean item code that specifies whether to override any character in the accessibility field of the ANSI volume label VOL1 on an ANSI magnetic tape. For more information, see the *VSI OpenVMS System Manager's Manual*.

To specify INIT\$_OVR_ACCESS, the caller must either own the volume or have VOLPRO privilege.

INIT\$_OVR_EXP

INIT\$_NO_OVR_EXP—Default

A Boolean item code that specifies whether the caller writes to a magnetic tape that has not yet reached its expiration date. This item code applies only to the magnetic tapes that were created before VAX/VMS Version 4.0 and that use the D% format in the volume owner identifier field.

To specify INIT\$_OVR_EXP, the caller must either own the volume or have VOLPRO privilege.

INIT\$_OVR_VOLO

INIT\$_NO_OVR_VOLO—Default

A Boolean item code that allows the caller to override processing of the owner identifier field of the ANSI volume label VOL1 on an ANSI magnetic tape.

To specify INIT\$_OVR_VOLO, the caller must either own the volume or have VOLPRO privilege.

INIT\$_OWNER

An input item code that specifies the UIC that will own the volume. The input buffer must contain a longword value, which is the UIC. The default is the UIC of the caller.

For magnetic tapes, no UIC is written unless protection on the magnetic tape is specified. If the INIT\$_VPROT item code is specified but the INIT\$_OWNER item code is not specified, the UIC of the caller is assigned ownership of the volume.

INIT\$_READCHECK

INIT\$_NO_READCHECK—Default

A Boolean item code that specifies whether data checking should be performed for all read operations on the volume. For more information about data checking, see the *VSI OpenVMS I/O User's Reference Manual*.

The INIT\$_READCHECK item code applies only to disks.

INIT\$_SIZE

An input item code that specifies the number of blocks allocated for a RAM disk with a device type of DT\$_RAM_DISK. The input buffer must contain a longword value.

INIT\$_SPECIAL_FILES—Default
INIT\$_NO_SPECIAL_FILES

Boolean item codes that control whether special files are enabled on the volume.

INIT\$_STRUCTURE_LEVEL_1
INIT\$_STRUCTURE_LEVEL_2—Default

Symbolic item codes that specify whether the volume should be formatted in Files-11 On-Disk Structure Level 1 or Structure Level 2. Structure Level 1 is incompatible with the following item codes:

- INIT\$_READCHECK
- INIT\$_WRITECHECK
- INIT\$_CLUSTERSIZE

The default protection for a Structure Level 1 disk is full access to system, owner, and group users, and read access to all other users.

The INIT\$_STRUCTURE_LEVEL_1 item code applies only to disks.

INIT\$_USER_NAME

An input item code that specifies the user name that is associated with the volume. The input buffer must contain a character string from 1 to 12 alphanumeric characters, which is the user name. The default is the user name of the caller.

INIT\$_VERIFIED
INIT\$_NO_VERIFIED

A Boolean item code that indicates whether the disk contains bad block data. INIT\$_NO_VERIFIED indicates that any bad block data on the disk should be ignored. For disks with 4096 blocks or more, the default is INIT\$_VERIFIED.

INIT\$_NO_VERIFIED is the default for the following:

- Disks with fewer than 4096 blocks
- DIGITAL Storage Architecture (DSA) devices
- Disks that are not last-track devices

The INIT\$_VERIFIED item codes apply only to disks.

INIT\$_VOLUME_LIMIT

An input item code that specifies the maximum logical volume size. For more information, see the DCL command INITIALIZE/LIMIT.

INIT\$_VPROT

An input item code that specifies the protection assigned to the volume. The input buffer must contain a longword protection mask that contains four 4-bit fields. Each field grants or denies read, write, create,

and delete access to a category of users. Cleared bits grant access; set bits deny access. The following diagram depicts the structure of the protection mask.

World				Group				Owner				System			
D	C	W	R	D	C	W	R	D	C	W	R	D	C	W	R
15	14	13	12	11	10	9	8	7	6	5	4	3	2	1	0

ZK-5893A-GE

The default is the default protection of the caller.

For magnetic tape, the protection code is written to a specific volume label. The system applies only read and write access restrictions; execute and delete access are ignored. Moreover, the system and the owner are always given read and write access to magnetic tapes, regardless of the protection mask specified.

When you specify a protection mask for a disk volume, access type E (execute) indicates create access.

For Files-11 On-Disk Structure Level 2 volumes, an initial security profile is created from the VOLUME.DEFAULT profile, with the owner and protection as currently defined for INITIALIZE.

You can use the \$SET_SECURITY service to modify the security profile after the volume is initialized and mounted.

The caller needs read, write, or control access to the device.

INIT\$_WINDOW

The INIT\$_WINDOW item code specifies the number of mapping pointers to be allocated for file windows. The input buffer must contain a longword value in the range 7 to 80. The default is 7.

When a file is opened, the file system uses the mapping pointers to access the data in the file.

The INIT\$_WINDOW item code applies only to disks.

INIT\$_WRITECHECK

INIT\$_NO_WRITECHECK—Default

A Boolean item code that specifies whether data checking should be performed for all read operations on the volume. For more information about data checking, see the *VSI OpenVMS I/O User's Reference Manual*.

The INIT\$_WRITECHECK item code applies only to disks.

Description

The Initialize Volume system service formats a disk or magnetic tape volume and writes a label on the volume. At the end of initialization, the disk is empty except for the system files containing the structure information. All former contents of the volume are lost.

A blank magnetic tape can sometimes cause unrecoverable errors when it is read. \$INIT_VOL attempts to read the volume unless the following three conditions are in effect:

- INIT\$_OVR_ACCESS Boolean item code is specified.
- INIT\$_OVR_EXP Boolean item code is specified.
- Caller has VOLPRO privilege.

If the caller has VOLPRO privilege, \$INIT_VOL initializes a disk without reading the ownership information; otherwise, the ownership of the volume is checked.

A blank disk or a diskette with an incorrect format can sometimes cause a fatal drive error. Such a diskette can be initialized successfully by specifying the INIT\$_DENSITY item code to format the diskette.

Required Access or Privileges

To initialize a particular volume, the caller must either have volume protection (VOLPRO) privilege or the volume must be one of the following:

- Blank disk or magnetic tape; that is, a volume that has never been written
- Disk that is owned by the caller's UIC or by the UIC [0,0]
- Magnetic tape that allows write access to the caller's UIC or that was not protected when it was initialized

Required Quota

None

Related Services

\$ALLOC, \$ASSIGN, \$BRKTHRU, \$BRKTHRUW, \$CANCEL, \$CREMBX, \$DALLOC, \$DASSGN, \$DELMBX, \$DEVICE_SCAN, \$DISMOU, \$GETDVI, \$GETDVIW, \$GETMSG, \$GETQUI, \$GETQUIW, \$MOUNT, \$PUTMSG, \$QIO, \$QIOW, \$SET_SECURITY, \$SNDERR, \$SNDJBC, \$SNDJBCW, \$SNDOPR

Condition Values Returned

SS\$_NORMAL

The service completed successfully.

SS\$_ACCVIO

The item list or an address specified in the item list cannot be accessed.

SS\$_BADPARAM

A buffer length of 0 was specified with a nonzero item code or an illegal item code was specified.

SS\$_IVSSRQ

A concurrent call to SYS\$INIT_VOL is already active for the process.

SS\$_NOPRIV

The caller does not have sufficient privilege to initialize the volume.

SS\$_NOSUCHDEV

The specified device does not exist on the host system.

The \$INIT_VOL service can also return the following condition values, which are specific to the Initialize Volume utility:

INIT\$_ALLOCFAIL

Index file allocation failure.

INIT\$_BADACCESSED

Value for INIT\$_ACCESSED item code out of range.

INIT\$_BADBLOCKS

Invalid syntax in bad block list.

INIT\$_BADCLUSTER

Value for INIT\$_CLUSTER_SIZE item code out of range.

INIT\$_BADDENS

Invalid value for INIT\$_DENSITY item code.

INIT\$_BADDIRECTORIES

Value for INIT\$_DIRECTORIES item code out of range.

INIT\$_BADEXTENSION

Value for INIT\$_EXTENSION item code out of range.

INIT\$_BADHEADERS

Value for INIT\$_HEADER item code out of range.

INIT\$_BADMAXFILES

Value for INIT\$_MAXFILES item code out of range.

INIT\$_BADOWNID

Invalid value for owner ID.

INIT\$_BADRANGE

Bad block address not on volume.

INIT\$_BADVOL1

Bad VOL1 ANSI label.

INIT\$_BADVOLACC

Invalid value for INIT\$_LABEL_ACCESS item code.

INIT\$_BADVOLLBL

Invalid value for ANSI tape volume label.

INIT\$_BADWINDOWS

Value for INIT\$_WINDOWS item code out of range.

INIT\$_BLKZERO

Block 0 is bad—volume not bootable.

INIT\$_CLUSTER

Unsuitable cluster factor.

INIT\$_CONFQUAL

Conflicting options were specified.

INIT\$_DIAGPACK

Disk is a diagnostic pack.

INIT\$_ERASEFAIL

Volume not completely erased.

INIT\$_FACTBAD

Cannot read factory bad block data.

INIT\$_ILLOPT

Item codes not appropriate for the device were specified.

INIT\$_INDEX

Invalid index file position.

INIT\$_LARGECONT

Disk too large to be supported.

INIT\$_MAXBAD

Bad block table overflow.

INIT\$_MTLBLELONG

Magnetic tape label specified is longer than 6 characters.

INIT\$_MTLBLENONA

Magnetic tape label specified contains non-ANSI "a" characters.

INIT\$_NOBADDATA

Bad block data not found on volume.

INIT\$_NONLOCAL

Device is not a local device.

INIT\$_NOTRAN

Logical name cannot be translated.

INIT\$_NOTSTRUC1

Options not available with Files-11 On-Disk Structure Level 1.

INIT\$_UNKDEV

Unknown device type.

\$IO_CLEANUP (Alpha and Integrity servers)

Clean Up Fast I/O — On Alpha and Integrity server systems, returns all resources allocated by \$IO_SETUP. This service accepts 64-bit addresses.

Format

`SYS$IO_CLEANUP fandle`

C Prototype

```
int sys$io_cleanup (unsigned __int64 fandl);
```

Arguments

fandle

OpenVMS usage: fandle
type: 64-bit integer (unsigned)
access: read only
mechanism: by value

A fandle, passed by value, returned by a previous call to \$IO_SETUP.

Description

The Clean Up Fast I/O system service returns various internal resources allocated by the \$IO_SETUP system service. Buffer objects passed to \$IO_SETUP cannot be deleted until every \$IO_SETUP call has had a corresponding \$IO_CLEANUP call.

Image rundown executes any required \$IO_CLEANUP operations on behalf of the process.

Required Privileges

None

Required Quota

None

Related Services

`$IO_PERFORM(W)`, `$IO_SETUP`

Condition Values Returned

`SS$_NORMAL`

The service completed successfully.

`SS$_BADFANDLE`

Argument was not a valid *fandle*.

`SS$_BUSY`

The fandle cannot be cleaned up because an I/O is in progress. Reissue the call to `$IO_CLEANUP` after the I/O has finished.

`$IO_FASTPATH` (Alpha and Integrity servers)

Control Fast Path Devices — On Alpha and Integrity server systems, provides the ability to control the set of Fast Path devices and their assignment to CPUs enabled for Fast Path use.

Format

```
SYSS$IO_FASTPATH
    efn, cpu_mask, function_code, [iosb], [astadr], [astprm] [, [mask_length]]
```

C Prototype

```
int sys$io_fastpath
(unsigned int efn, UINT32_PQ cpu_mask, int function_code,
 struct_iosb *iosb, void (*astadr)(__unknown_params),
 __int64 astprm, ...);
```

Arguments

efn

OpenVMS usage: integer
type: longword bit mask (unsigned)
access: read
mechanism: by value

Number of the event flag to be set when the `IO_FASTPATH(W)` operation completes. The *efn* argument is a longword containing the number of the event flag.

cpu_mask

OpenVMS usage: bitmap

type: quadword bitmap
access: read
mechanism: by 32- or 64-bit reference

The *cpu_mask* argument specifies a set of CPUs to be operated upon.

function_code

OpenVMS usage: integer
type: longword (unsigned)
access: read
mechanism: by value

The *function_code* specifies the operation to be performed. Note that there is currently only one function code:

FP\$K_BALANCE_PORTS - Distribute Fast Path ports across CPUs.

mask_length

OpenVMS usage: integer
type: longword length
access: read
mechanism: by value

The *mask_length* specifies the length of the *cpu_mask* bitmap in bytes. If the *mask_length* is not supplied or is specified as zero, a length of 4 bytes is used.

Description

The \$IO_FASTPATH system service performs operations on the set of Fast Path devices and CPUs enabled for Fast Path use. The \$IO_FASTPATHW system service completes synchronously. That is, it returns after the operation is complete.

The FP\$K_BALANCE_PORTS function code specifies that the system service is to distribute the set of system assignable Fast Path ports across the intersection of a caller-supplied set of candidate CPUs (*cpu_mask*) and the current set of usable CPUs. Usable CPUs are the intersection of the set of CPUs both enabled for Fast Path use by IO\$_PREFERRED_CPUS and whose current state is RUN.

The service does this by:

1. Eliminating all CPUs not in the set of usable CPUs from the set of candidate CPUs.
2. Restoring any user assigned ports that are not currently on the user's preferred CPU to the user's preferred CPU, if that CPU is in the set of usable CPUs.
3. Spreading the system assignable Fast Path ports, and any Fast Path ports whose user preferred CPU is unavailable, evenly across the set of usable candidate CPUs.

If the primary CPU is in the set of usable candidate CPUs, the distribution will be biased against the primary CPU in that a port will only be assigned to the primary after ports have been assigned to each of the other usable candidate CPUs.

Required Access or Privileges

PHYS_IO

Required Quota

None

Related Services

\$GETDVI, \$QIO

Condition Values Returned

SS\$_NORMAL

The service completed successfully.

SS\$_BADPARAM

Unsupported value for `cpu_mask`.

SS\$_ILLIOFUNC

Illegal function code.

\$IO_FASTPATHW

Control Fast Path Devices — On Alpha and Integrity server systems, performs operations on the set of Fast Path devices and CPUs enabled for Fast Path use. The `$IO_FASTPATHW` system service is functionally equivalent to the `$IO_FASTPATH` service except that it completes synchronously. That is, it returns after the operation is complete.

Format

```
SYS$IO_FASTPATHW
    efn, cpu_mask, function_code, [iosb], [astadr], [astprm],
    [, [mask_length]]
```

C Prototype

```
int sys$io_fastpathw
(unsigned int efn, UINT32_PQ cpu_mask, int function_code,
 struct_iosb *iosb, void (*astadr)( _ _unknown_params),
 _ _int64 astprm, ...);
```

\$IO_PERFORM (Alpha and Integrity servers)

Perform Fast I/O — On Alpha and Integrity server systems, starts the Fast I/O operation. The `$IO_PERFORM` service completes asynchronously. For synchronous completion, use the Perform Fast I/O and Wait (`$IO_PERFORMW`) service. This service accepts 64-bit addresses.

Format

```
SYSSIO_PERFORM fandle ,chan ,iosadr ,bufadr ,buflen ,devdata
```

C Prototype

```
int sys$io_perform
(unsigned __int64 fandle, unsigned short int chan, struct _iosa *iosadr,
 void *bufadr, unsigned __int64 buflen, unsigned __int64 devdata);
```

Arguments

fandle

OpenVMS usage: fandle
type: 64-bit integer (unsigned)
access: read only
mechanism: by value

A fandle returned by a previous call to \$IO_SETUP.

chan

OpenVMS usage: channel
type: word (unsigned)
access: read
mechanism: by value

Software I/O channel number.

iosadr

OpenVMS usage: address
type: address
access: read only
mechanism: by value

Address of the I/O Status Area (IOSA). This value cannot be 0; that is, an IOSA is required. The *iosadr* must be aligned to a quadword boundary.

bufadr

OpenVMS usage: char_string
type: address
access: read only
mechanism: by value

The process buffer address. Must be aligned on a 512-byte boundary.

buflen

OpenVMS usage: byte count
type: 64-bit integer
access: read only
mechanism: by value

The byte count for the I/O. The *buflen* argument must be a multiple of 512 bytes. Drivers have further limitations on the maximum size of an I/O request.

devdata

OpenVMS usage: address
type: pointer or integer
access: read only
mechanism: by value

A hardware integer passed unchanged to the driver. For disk devices, this is the media address for the transfer; that is, the virtual block number (VBN) for virtual I/O functions or the logical block number (LBN) for logical I/O functions. This argument is ignored for tape devices.

For drivers with complex parameters, *devdata* would be the address of a descriptor or buffer specific to the device and function and would be documented with the driver.

Description

The Perform Fast I/O system service initiates an I/O operation on the channel number specified by the *chan* argument. The bytes specified by the *buflen* argument are transferred between the location (*devdata*) on the device driver and the user's buffer starting at the process buffer address (*bufadr*). The byte count is read or written according to the function code previously specified in the \$IO_SETUP call associated with the *fandle* argument.

Upon completion, the I/O status is written to the IOSA starting at the location specified by *iosadr*, and an AST is delivered to the *astadr* address supplied in the \$IO_SETUP call associated with *fandle*. The IOSA address is passed to the AST as the AST parameter.

Required Privileges

None

Required Quota

None

Related Services

\$IO_CLEANUP, \$IO_SETUP, \$IO_PERFORMW

Condition Values Returned

SS\$_NORMAL

The service completed successfully.

SS\$_BADBUFADR

The data buffer does not reside within the bounds of the data buffer object for the fandle.

SS\$_BADIOSADR

The IOSA does not reside within the bounds of the IOSA buffer object for this fandle.

SS\$_FANDLEBUSY

The operation using this fandle is already in progress.

SS\$_IVCHAN

An invalid channel number was specified; that is, a channel number of 0 or a number larger than the number of channels available.

SS\$_UNALIGNED

The buffer specified by *bufadr* or *iosadr* is not properly aligned.

SS\$_WRONGACMODE

The request is invalid because the *fandle* was created from a more privileged access mode, or the channel was assigned from a more privileged access mode.

Condition Values Returned in the I/O Status Block

The *VSI OpenVMS I/O User's Reference Manual* lists these device-specific condition values for each device.

\$IO_PERFORMW (Alpha and Integrity servers)

Perform Fast I/O and Wait — On Alpha and Integrity server systems, starts a Fast I/O operation. The `$IO_PERFORMW` service completes synchronously; that is, it returns to the caller after performing the Fast I/O operation. In all other respects, `$IO_PERFORMW` is identical to `$IO_PERFORM`. For all other information about the `IO_PERFORMW` service, see the description of `$IO_PERFORM` in this manual.

Format

```
SYS$IO_PERFORMW fandle ,chan ,iosadr ,bufadr ,buflen ,devdata
```

C Prototype

```
int sys$io_performw
(unsigned __int64 fandl, unsigned short int chan, struct _iosa *iosadr,
void *bufadr, unsigned __int64 buflen, unsigned __int64 devdata);
```

\$IO_SETUP (Alpha and Integrity servers)

Set Up Fast I/O — On Alpha and Integrity server systems, allocates resources for Fast I/O. This service accepts 64-bit addresses.

Format

`SYS$IO_SETUP func ,bufobj ,iosobj ,astadr ,flags ,return_fandle`

C Prototype

```
int sys$io_setup
(unsigned int func, struct _generic_64 *bufobj,
 struct _generic_64 *iosobj, void (*astadr)(struct _iosa *),
 unsigned int flags, unsigned __int64 *return_fandle);
```

Arguments

func

OpenVMS usage: function_code
type: longword
access: read only
mechanism: by value

I/O function code. Must be one of the following:

- IO\$_READVBLK
- IO\$_WRITEVBLK
- IO\$_READLBLK
- IO\$_WRITELBLK

Various function modifiers are supported, depending on the device and driver. Disk drivers support IO\$_NOVCACHE and IO\$_DATACHECK. Some tape devices support IO\$_REVERSE. Illegal modifiers are detected by the \$IO_PERFORM(W) service.

bufobj

OpenVMS usage: buffer object
type: quadword (unsigned)
access: read only
mechanism: by 32- or 64-bit reference

Handle describing the buffer object that contains the user's buffer. This identifier cannot be 0.

iosobj

OpenVMS usage: object handle
type: vector longword (unsigned)
access: read only
mechanism: by 32- or 64-bit reference

Buffer object handle describing the buffer object that contains the I/O Status Area (IOSA). This might or might not be the same identifier as the *bufobj* argument. This identifier cannot be 0.

astadr

OpenVMS usage: ast_procedure
 type: procedure value
 access: read only
 mechanism: by 32- or 64-bit reference

Completion AST routine address (0, if none). There is no *AST parameter* argument. When the AST routine is called, the AST parameter will be the address of the IOSA for the operation. Applications can store data in the IOSA at offset IOSA\$IH_CONTEXT.

flags

OpenVMS usage: mask_longword
 type: 64-bit integer (unsigned)
 access: read only
 mechanism: by value

Flag mask. The *flags* argument is a bit vector in which each bit corresponds to a flag. Flags are defined in the module IOSADEF. The following table describes the flags that are valid for the \$IO_SETUP service:

Flag	Description
FIO\$M_EXPEDITE	This is a <i>high priority I/O</i> ; that is, it is to be given preferential treatment by the I/O subsystem. Use of this bit requires ALTPRI or PHY_IO privilege.
FIO\$M_AST_NOFLOAT	The AST procedure does not use, or call any procedure that uses, any floating-point registers. This is a performance option. If set, AST delivery will neither save nor restore floating-point registers. Caution: Use of floating-point registers when FIO\$M_AST_NOFLOAT has been specified can cause unpredictable, difficult to detect, error conditions.

All other bits in the *flags* argument are reserved for future OpenVMS use and should be specified as 0.

return_fandle

OpenVMS usage: fandle
 type: 64-bit integer (unsigned)
 access: write only
 mechanism: by 32- or 64-bit reference

Address of an aligned quadword to receive the handle for this I/O operation.

Description

The Set Up Fast I/O system service allocates and initializes a number of internal objects based on the parameters supplied. Because these objects are then ready for use when a subsequent \$IO_PERFORM or \$IO_PERFORMW is issued, the I/O operation will require less CPU time and fewer multiprocessor steps.

Required Privileges

If you use the *flags* argument FIO\$M_EXPEDITE, a process must have ALTPRI or PHY_IO privilege.

Required Quota

Byte count

Related Services

\$IO_CLEANUP, \$IO_PERFORM(W)

Condition Values Returned

SS\$_NORMAL

The service completed successfully.

SS\$_ACCVIO

The fandle does not have 8 bytes of writability, or the two buffer objects do not have 8 bytes of readability each.

SS\$_BADPARAM

Invalid flags options specified.

SS\$_EXBUFOBJLM

Buffer object cannot be created because it would bring the total number of buffer object pages above the systemwide limit MAXBOBMEM.

SS\$_ILLBUFOBJ

The buffer object is not valid.

SS\$_ILLIOFUNC

The function code is not valid.

SS\$_ILLMODIFIER

The I/O function modifier is not permitted.

SS\$_INSFMEM

There is no pool available from which to create a fandle vector, or the fandle vector is already full and an attempted expansion failed.

SS\$_INSFSPTS

Insufficient system page table entries.

SS\$_IVSTSFLG

The specified status flag is invalid.

SS\$_NOBUFOBJID

The process attempted to create a buffer object from user mode but was not holding required rights identifier VMS\$BUFFER_OBJECT_USER.

SS\$_NOPRIV

Valid flag options were specified but from user mode.

SS\$_PAGNOTWRITE

A page within the address range is not writable.

SS\$_PAGOWNVIO

Page owner violation. The pages could not be put into the buffer object because the access mode associated with the call to \$IO_SETUP was less privileged than the access mode associated with the pages. See \$CREATE_BUFOBJ_64 for additional information.

SS\$_UNALIGNED

The I/O Status Area (IOSA) or data buffer is not aligned on a quadword boundary.

\$JOIN_RM

JoinResourceManager — Adds a new Resource Manager (RM) participant to a transaction.

Format

```
SYS$JOIN_RM
  [efn] , [flags] , iosb , [astadr] , [astprm] , rm_id
  [, [tid] , [part_name] , [rm_context] , [timeout] , [bid] ]
```

C Prototype

```
int sys$join_rm
(unsigned int efn, unsigned int flags, struct _iosb *iosb,
 void (*astadr)(__unknown_params), int astprm, unsigned int rm_id,...);
```

Arguments

efn

OpenVMS usage: ef_number
type: longword (unsigned)
access: read only
mechanism: by value

Number of the event flag that is set when the service completes. If this argument is omitted, event flag 0 is used.

flags

OpenVMS usage: mask_longword
 type: longword (unsigned)
 access: read only
 mechanism: by value

Flags specifying options for the service. The *flags* argument is a longword bit mask in which each bit corresponds to an option flag. The \$DDTMDEF macro defines symbolic names for these option flags described in Table 4. All undefined bits must be 0. If this argument is omitted, no flags are used.

Table 4. \$JOIN_RM Option Flags

Flag Name	Description
DDTM\$M_COORDINATOR	Set this flag to specify that the new RM participant is to be a coordinator of the transaction on this node.
DDTM\$M_SYNC	Specifies successful synchronous completion by returning SS\$_SYNCH. When SS\$_SYNCH is returned, the AST routine is not called, the event flag is not set, and the I/O status block is not filled in.

iosb

OpenVMS usage: io_status_block
 type: quadword (unsigned)
 access: write only
 mechanism: by reference

The I/O status block in which the completion status of the service is returned as a condition value. See the Condition Values Returned section.

The following diagram shows the structure of the I/O status block:

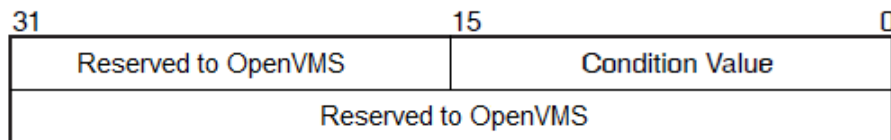

VM-0778A-AI

astadr

OpenVMS usage: **ast_procedure**
 type: **procedure entry mask**
 access: **call without stack unwinding**
 mechanism: **by reference**

The AST routine that is executed when the service completes, if SS\$_NORMAL is returned in R0. The *astadr* argument is the address of the entry mask of this routine. The routine is executed in the same access mode as that of the caller of the \$JOIN_RM service.

astprm

OpenVMS usage: user_arg

type: longword (unsigned)
access: read only
mechanism: by value

The AST parameter that is passed to the AST routine specified by the *astadr* argument.

rm_id

OpenVMS usage: identifier
type: longword (unsigned)
access: read only
mechanism: by value

The identifier of the RMI with which the new RM participant is associated. This identifies:

- Types of event that are to be reported to the new RM participant.
- Event handler to which these event reports are to be delivered, and the access mode in which its ASTs are to be fired.
- Minimum access mode that the new RM participant must be in to acknowledge one of these event reports by calling \$ACK_EVENT.
- Whether or not the DECdtm transaction manager may log information about the new RM participant.

tid

OpenVMS usage: trans_id
type: octaword (unsigned)
access: read only
mechanism: by reference

The identifier (TID) of the transaction to which the new RM participant is to be added.

If this argument is omitted (the default) or its value is zero, \$JOIN_RM adds an RM participant to the default transaction of the calling process.

part_name

OpenVMS usage: char_string
type: character-coded text string
access: read only
mechanism: by descriptor--fixed-length string descriptor

The name of the new RM participant.

Used by recoverable resource managers to specify the RM participant to use in a subsequent call to \$GETDTI or \$SETDTI during recovery.

This argument has no effect if the RMI is volatile. If this argument is omitted (the default) or its value is zero, the name of the new RM participant is the same as that of the RMI with which it is associated.

The string passed in this argument can be no longer than 32 characters.

To ensure smooth operation in a mixed-network environment, refer to the chapter entitled Managing DECdtm Services in the *VSI OpenVMS System Manager's Manual*, for information on defining node names.

rm_context

OpenVMS usage: userarg
type: longword (unsigned)
access: read only
mechanism: by value

The context associated with the new RM participant. This is passed in the event reports subsequently delivered to the new RM participant.

If this argument is omitted (the default) or is zero, the context associated with the new RM participant is the same as that of the RMI with which it is associated.

timeout

OpenVMS usage: date_time
type: quadword (unsigned)
access: read only
mechanism: by reference

Reserved to OpenVMS.

bid

OpenVMS usage: branch_id
type: octaword (unsigned)
access: write only
mechanism: by reference

The identifier of an authorized branch (BID) that may be added to the transaction by a subsequent call to \$START_BRANCH on the same node as that of the RMI. This argument is ignored if the DDTM\$M_COORDINATOR flag is clear in the *flags* argument. The call to \$START_BRANCH should specify the node of the RMI for the *tm_name* argument.

Description

The \$JOIN_RM system service:

- Adds a new RM participant to the specified transaction. The new RM participant is associated with the RMI whose identifier is passed in the *rm_id* argument.
- Introduces a new transaction to DECdtm if the new RM participant is a coordinator and the specified transaction is unknown to DECdtm.
- Authorizes a new branch of the transaction if the new RM participant is a coordinator.

Preconditions for the successful completion of \$JOIN_RM are:

- Unless the DDTM\$M_COORDINATOR flag is set, the calling process must contain at least one branch of the specified transaction.
- The calling process must contain the specified RMI.
- The caller must not be in a less privileged mode than the access mode of the specified RMI.
- If the DDTM\$M_COORDINATOR flag is set, either the calling process must have the SYSPRV privilege, or the caller must be in executive or kernel mode.
- If the DDTM\$M_COORDINATOR flag is set, the specified RMI must not be volatile. That is, the DDTM\$M_VOLATILE flag must not have been set on the call to the \$DECLARE_RM that created it.
- The access mode of the specified RMI must not be less privileged than that of the specified transaction in this process.

\$JOIN_RM can fail for various reasons, including:

- Preconditions were not met.
- The DDTM\$M_COORDINATOR flag was set, but no *bid* argument was supplied.

When \$JOIN_RM completes successfully, a new RM participant running in the calling process is added to the transaction. This RM participant is associated with the specified RMI.

The DECdtm transaction manager will report to the new RM participant the types of event specified in the call to \$DECLARE_RM that created the RMI with which it is associated. Note however that events of type prepare, one-phase commit, and commit are never reported to RM participants that set the DDTM\$M_COORDINATOR flag on the call to \$JOIN_RM.

If the call to \$DECLARE_RM requested prepare and one-phase commit events, and the \$JOIN_RM call does not set the DDTM\$M_COORDINATOR flag, the new RM participant is entitled to a vote on the outcome of the transaction.

If the \$JOIN_RM call sets the DDTM\$M_COORDINATOR flag, then the new RM participant is expected to initiate commit or abort processing by a call to \$TRANS_EVENT. No events of type prepare, one-phase commit, or commit are delivered to the RM participant.

Events of type abort are reported to the RM participant.

The new RM participant is removed from the transaction when the first of the following conditions is met:

- On successful completion of a call to \$ACK_EVENT that acknowledges an event report delivered to that RM participant, if the event and its acknowledgment were one of those listed in the following table:

Event	Acknowledgment (report_reply)
Abort	SS\$_FORGET
Commit	SS\$_FORGET or SS\$_REMEMBER
Prepare	SS\$_FORGET
One-phase commit	SS\$_NORMAL or SS\$_VETO

- On completion of a successful call to \$TRANS_EVENT that specifies a commit or abort event, if the DDTM\$M_COORDINATOR flag is set.
- When a commit or abort event occurs, and no associated event report is delivered to the RM participant.
- On successful completion of a call to \$FORGET_RM that deletes the RMI with which it is associated.
- When the current process terminates (normally or abnormally).
- When the current image terminates (normally or abnormally).

If the DDTM\$M_COORDINATOR flag is set:

- A new branch is authorized for the transaction and its identifier is returned in the octaword that the *bid* argument points to. \$JOIN_RM uses the \$CREATE_UID system service to generate the BID. No other call to \$ADD_BRANCH, \$JOIN_RM, or \$CREATE_UID on any other node ever returns the same BID value.
- The transaction cannot commit until the new branch has been started by a matching call to \$START_BRANCH. (See the description of \$START_BRANCH for the definition of a matching call to \$START_BRANCH.)
- If the transaction is not already known to this process, then the transaction is introduced to this process with an access mode equal to the access mode of the caller. (See the description of \$START_TRANS for a definition of the access mode of a transaction.)

There is also a wait form of the service, \$JOIN_RMW.

Required Privileges

If the DDTM\$M_COORDINATOR flag is set, then either the calling process must have the SYSPRV privilege or the caller must be in executive or kernel mode.

Required Quotas

BYTLM, ASTLM

Related Services

\$ABORT_TRANS, \$ABORT_TRANSW, \$ACK_EVENT, \$ADD_BRANCH, \$ADD_BRANCHW, \$CREATE_UID, \$DECLARE_RM, \$DECLARE_RMW, \$END_BRANCH, \$END_BRANCHW, \$END_TRANS, \$END_TRANSW, \$FORGET_RM, \$FORGET_RMW, \$GETDTI, \$GETDTIW, \$GET_DEFAULT_TRANS, \$JOIN_RMW, \$SETDTI, \$SETDTIW, \$SET_DEFAULT_TRANS, \$SET_DEFAULT_TRANSW, \$START_BRANCH, \$START_BRANCHW, \$START_TRANS, \$START_TRANSW, \$TRANS_EVENT, \$TRANS_EVENTW

Condition Values Returned

SS\$_NORMAL

If returned in R0, the request was successfully queued. If returned in the I/O status block, the service completed successfully.

SS\$_SYNCH

The service completed successfully and synchronously (returned only if the DDTM\$_SYNC flag is set).

SS\$_ACCVIO

An argument was not accessible to the caller.

SS\$_BADPARAM

The options flags were invalid, the specified *tid* was invalid, or DDTM\$_COORDINATOR set but no *bid* supplied.

SS\$_EXASTLM

The process AST limit (ASTLM) was exceeded.

SS\$_EXQUOTA

The job buffered I/O byte limit quota (BYTLM) was exceeded.

SS\$_ILLEFC

The event flag number was invalid.

SS\$_INSFARGS

A required argument was missing.

SS\$_INSMEM

There was insufficient system dynamic memory for the operation.

SS\$_INVBUFLN

The string passed in the *part_name* argument was too long.

SS\$_NOSYSPRIV

The DDTM\$_COORDINATOR flag was set and the caller was in user or supervisor mode but the calling process did not have the SYSPRV privilege.

SS\$_NOCURTID

An attempt was made to add a new participant to the default transaction (the *tid* argument was zero or omitted) but the calling process did not have a default transaction.

SS\$_NOSUCHTID

The DDTM\$_COORDINATOR flag was clear and the calling process did not contain any branches in the transaction.

SS\$_NOSUCHRM

The calling process did not contain the specified RMI.

SS\$_WRONGACMODE

The caller was in a less privileged access mode than that of the RMI.

SS\$_WRONGSTATE

The transaction was in the wrong state for the attempted operation because either:

- An abort event had occurred for the transaction.
- A call to \$END_TRANS to end the transaction was in progress and it is too late to add a new RM participant to the transaction.

\$JOIN_RMW

Join Resource Manager and Wait — Adds a new Resource Manager (RM) participant to a transaction. \$JOIN_RMW always waits for the request to complete before returning to the caller. Other than this, it is identical to \$JOIN_RM.

Format

```
SYS$JOIN_RMW
    [efn] , [flags] , iosb , [astadr] , [astprm] , rm_id
    [ , [tid] , [part_name] , [rm_context] , [timeout] , [bid] ]
```

C Prototype

```
int sys$join_rmw
    (unsigned int efn, unsigned int flags, struct _iosb *iosb,
     void (*astadr)(__unknown_params), int astprm, unsigned int rm_id,...);
```

\$LCKPAG

Lock Pages in Memory — Locks a page or range of pages in memory. The specified virtual pages are forced into the working set and then locked in memory. A locked page is not swapped out of memory if the working set of the process is swapped out. These pages are not candidates for page replacement and in this sense are locked in the working set as well.

Format

```
SYS$LCKPAG inadr , [retadr] , [acmode]
```

C Prototype

```
int sys$lckpag
    (struct _va_range *inadr, struct _va_range *retadr,
     unsigned int acmode);
```

Arguments

inadr

OpenVMS usage: address_range
type: longword (unsigned)
access: read only
mechanism: by reference

Starting and ending virtual addresses of the range of pages to be locked. The *inadr* argument is the address of a 2-longword array containing, in order, the starting and ending process virtual addresses. Only the virtual page number portion of each virtual address is used; the low-order byte-within-page bits are ignored.

retadr

OpenVMS usage: address_range
type: longword (unsigned)
access: write only
mechanism: by reference

Starting and ending process virtual addresses of the pages that \$LCKPAG actually locked. The *retadr* argument is the address of a 2-longword array containing, in order, the starting and ending process virtual addresses.

acmode

OpenVMS usage: access_mode
type: longword (unsigned)
access: read only
mechanism: by value

Access mode to be associated with the pages to be locked. The *acmode* argument is a longword containing the access mode. The \$PSLDEF macro defines the four access modes.

The most privileged access mode used is the access mode of the caller. For the \$LCKPAG service to complete successfully, the resultant access mode must be equal to or more privileged than the access mode already associated with the pages to be locked.

Description

The Lock Pages in Memory service locks a page or range of pages in memory. The specified virtual pages are forced into the working set and then locked in memory. A locked page is not swapped out of memory if the working set of the process is swapped out. These pages are not candidates for page replacement and in this sense are locked in the working set as well.

If more than one page is being locked and you need to determine specifically which pages were previously locked, the pages should be locked one at a time.

If an error occurs while the \$LCKPAG service is locking pages, the return array, if requested, indicates the pages that were successfully locked before the error occurred. If no pages are locked, both longwords in the return address array contain the value -1.

On Alpha and Integrity server systems, if you are attempting to lock executable code, you should issue multiple \$LCKPAG calls: one to lock the code pages and others to lock the linkage section references into these pages.

Required Access or Privileges

The calling process must have PSWAPM privilege to lock pages into memory.

Required Quota

None

Related Services

You can unlock pages locked in memory with the Unlock Pages from Memory (\$ULKPAG) service. Locked pages are automatically unlocked at image exit.

For more information, see the chapter on memory management in the *VSI OpenVMS Programming Concepts Manual*.

Condition Values Returned

SS\$_WASCLR

The service completed successfully. All of the specified pages were previously unlocked.

SS\$_WASSET

The service completed successfully. At least one of the specified pages was previously locked.

SS\$_ACCVIO

The input array cannot be read; the output array cannot be written; the page in the specified range is inaccessible or nonexistent; or an attempt to lock pages was made by a caller whose access mode is less privileged than the access mode associated with the pages.

SS\$_LCKPAGFUL

The system-defined maximum limit on the number of pages that can be locked in memory has been reached.

SS\$_LDWSETFUL

The locked working set is full. If any more pages are locked, not enough dynamic pages will be available to continue execution.

SS\$_NOPRIV

The process does not have the privilege to lock pages in memory.

SS\$_PAGOWNVIO

The pages could not be locked because the access mode associated with the call to \$LCKPAG was less privileged than the access mode associated with the pages that were to be locked.

\$LCKPAG_64 (Alpha and Integrity servers)

Lock Pages in Memory — On Alpha and Integrity server systems, locks a range of pages in memory. The specified virtual pages are forced into the working set and then locked in memory. A locked page

is not swapped out of memory if the working set of the process is swapped out. These pages are not candidates for page replacement and, in this sense, are locked in the working set as well. This service accepts 64-bit addresses.

Format

```
SYS$LCKPAG_64
    start_va_64 , length_64 , acmode , return_va_64 , return_length_64
```

C Prototype

```
int sys$lckpag_64
    (void *start_va_64, unsigned __int64 length_64, unsigned int acmode,
     void *(*return_va_64), unsigned __int64 *return_length_64);
```

Arguments

start_va_64

OpenVMS usage: address
type: quadword address
access: read only
mechanism: by value

The starting virtual address of the pages to be locked. The specified virtual address will be rounded down to a CPU-specific page boundary.

length_64

OpenVMS usage: byte count
type: quadword (unsigned)
access: read only
mechanism: by value

Length of the virtual address space to be locked. The specified length will be rounded up to a CPU-specific page boundary so that it includes all CPU-specific pages in the requested range.

acmode

OpenVMS usage: access_mode
type: longword (unsigned)
access: read only
mechanism: by value

Access mode associated with the pages to be locked. The *acmode* argument is a longword containing the access mode.

The \$PSLDEF macro in STARLET.MLB and the file PSLDEF.H in SYS\$STARLET_C.TLB define the following symbols and their values for the four access modes:

Value	Symbolic Name	Access Mode
0	PSL\$C_KERNEL	Kernel
1	PSL\$C_EXEC	Executive
2	PSL\$C_SUPER	Supervisor
3	PSL\$C_USER	User

The most privileged access mode used is the access mode of the caller. For the \$LCKPAG_64 service to complete successfully, the resultant access mode must be equal to or more privileged than the access mode already associated with the pages to be locked.

return_va_64

OpenVMS usage: address
 type: quadword address
 access: write only
 mechanism: by 32- or 64-bit reference

The lowest process virtual address of the pages locked in memory. The *return_va_64* argument is the 32- or 64-bit virtual address of a naturally aligned quadword into which the service returns the virtual address.

return_length_64

OpenVMS usage: byte count
 type: quadword (unsigned)
 access: write only
 mechanism: by 32- or 64-bit reference

The 32- or 64-bit virtual address of a naturally aligned quadword into which the service returns the length of the virtual address range locked in bytes.

Description

The Lock Pages in Memory service locks a range of pages in memory. The specified virtual pages are forced into the working set and then locked in memory. A locked page is not swapped out of memory if the working set of the process is swapped out. These pages are not candidates for page replacement and, in this sense, are locked in the working set as well.

If the condition value SS\$_ACCVIO is returned by this service, a value *cannot* be returned in the memory locations pointed to by the *return_va_64* and *return_length_64* arguments. If a condition value other than SS\$_ACCVIO is returned, the returned address and returned length indicate the pages that were successfully locked before the error occurred. If no pages were locked, the *return_va_64* argument will contain the value -1, and a value *cannot* be returned in the memory location pointed to by the *return_length_64* argument.

Required Privileges

A process must have PSWAPM privilege to call the \$LCKPAG_64 service.

Required Quota

None.

Related Services

`$LCKPAG`, `$ULKPAG`, `$ULKPAG_64`

Condition Values Returned

`SS$_WASCLR`

The service completed successfully. All of the specified pages were previously unlocked.

`SS$_WASSET`

The service completed successfully. At least one of the specified pages was previously locked in the working set.

`SS$_ACCVIO`

The `return_va_64` argument or the `return_length_64` argument cannot be written by the caller, or an attempt was made to lock pages by a caller whose access mode is less privileged than the access mode associated with the pages.

`SS$_LCKPAGFUL`

The system-defined maximum limit on the number of pages that can be locked in memory has been reached.

`SS$_LKWSETFUL`

The locked working set is full. If any more pages are locked, not enough dynamic pages will be available to continue execution.

`SS$_NOPSWAPM`

The process does not have the privilege to lock pages in memory.

`SS$_PAGOWNVIO`

The pages could not be locked because the access mode associated with the call to `$LCKPAG_64` was less privileged than the access mode associated with the pages that were to be locked.

`$LKWSET`

Lock Pages in Working Set — Locks a range of pages in the working set; if the pages are not already in the working set, it brings them in and locks them. A page locked in the working set does not become a candidate for replacement.

Format

```
SYS$LKWSET inadr , [retadr] , [acmode]
```

C Prototype

```
int sys$lkwset
    (struct _va_range *inadr, struct _va_range *retadr,
     unsigned int acmode);
```

Arguments

inadr

OpenVMS usage: address_range
type: longword (unsigned)
access: read only
mechanism: by reference

Starting and ending virtual addresses of the range of pages to be locked in the working set. The *inadr* argument is the address of a 2-longword array containing, in order, the starting and ending process virtual addresses. Only the virtual page number portion of each virtual address is used; the low-order byte-within-page bits are ignored.

On Alpha and Integrity server systems, if the first address in the 2-longword array is within an image mapped to your process, the entire image specified by the address is locked in the working set.

Be sure to check calls to the SYS\$LKWSET and SYS\$LKWSET_64 system services for correct arguments. This affects only process-based code running above IPL2. Compiler and linker differences might cause your program layout to change from Alpha, resulting in incorrectly calculated starting and ending addresses for calls to SYS\$LKWSET and SYS\$LKWSET_64. Calling these services with incorrect arguments and then executing this code above IPL2 could cause PGFIPLHI bugchecks. Note that SYS\$LKWSET and SYS\$LKWSET_64 automatically lock linker-generated short data sections associated with code sections locked in the working set.

retadr

OpenVMS usage: address_range
type: longword (unsigned)
access: write only
mechanism: by reference

Starting and ending process virtual addresses of the range of pages actually locked by \$LKWSET. The *retadr* argument is the address of a 2-longword array containing, in order, the starting and ending process virtual addresses.

On Alpha and Integrity server systems, if the *inadr* argument specifies an address within an image mapped to your process, *retadr* specifies only one range of pages locked in the working set. Many ranges of pages might be locked.

acmode

OpenVMS usage: access_mode
type: longword (unsigned)
access: read only

mechanism: by value

Access mode to be associated with the pages to be locked. The *acmode* argument is a longword containing the access mode. The \$PSLDEF macro defines the four access modes.

The most privileged access mode used is the access mode of the caller. For the \$LKWSET service to complete successfully, the resultant access mode must be equal to or more privileged than the access mode already associated with the pages to be locked.

Description

The Lock Pages in Working Set service locks a range of pages in the working set; if the pages are not already in the working set, it brings them in and locks them. A page locked in the working set does not become a candidate for replacement.

If more than one page is being locked and you need to determine specifically which pages were previously locked, the pages should be locked one at a time.

If an error occurs while the \$LKWSET service is locking pages, the return array, if requested, indicates the pages that were successfully locked before the error occurred. If no pages are locked, both longwords in the return address array contain the value -1.

Global pages with write access cannot be locked into the working set.

On Alpha and Integrity server systems, if the first address specified to SYS\$LKWSET is within an image mapped to your process, a success status indicates that the entire image containing the specified address is locked in the working set. This behavior helps to ensure that privileged processes entering kernel mode and raising IPL higher than IPL 2 do not access an invalid page and cause a PGFIPLHI bugcheck. The system keeps a count of the number of times each image within your process is locked in the working set. This count is maintained so that calls to SYS\$ULWSET unlock the image only when it has been called the same number of times as SYS\$LKWSET.

If an attempt to lock an image in the working set returns SS\$_LKWSETFUL, you might consider moving all kernel mode code within the image to a separate, smaller sharable image. Otherwise, you might consider increasing the working set quota of the process.

The LIBRTL routine LIB\$LOCK_IMAGE and LIB\$UNLOCK_IMAGE are preferable to SYS\$LKWSET and SYS\$ULKWSET for locking code and related data in the working set. For more information about locking images in the working set, see the LIBRTL manual and the descriptions of LIB\$LOCK_IMAGE and LIB\$UNLOCK_IMAGE.

Required Access or Privileges

None

Required Quota

None

Related Services

You can unlock pages locked in the working set with the Unlock Page from Working Set (\$ULWSET) service.

For more information, see the chapter on memory management in the *VSI OpenVMS Programming Concepts Manual*.

Condition Values Returned

SS\$_WASCLR

The service completed successfully. All of the specified pages were previously unlocked. The entire image might have been locked in the working set.

SS\$_WASSET

The service completed successfully. At least one of the specified pages was previously locked in the working set. If the image has been locked in the working set, the count of times the image has been locked in the working set has been incremented.

SS\$_ACCVIO

The input address array cannot be read; the output address array cannot be written; a page in the specified range is inaccessible or nonexistent; or an attempt was made to lock pages by a caller whose access mode is less privileged than the access mode associated with the pages. If the image is being locked in the working set, the image is too large to be entirely locked in the working set.

SS\$_LKWSETFUL

The locked working set is full. If any more pages are locked, not enough dynamic pages will be available to continue execution.

SS\$_NOPRIV

A page in the specified range is in the system address space, or a global page with write access was specified.

SS\$_PAGOWNVIO

The pages could not be locked because the access mode associated with the call to \$LKWSET was less privileged than the access mode associated with the pages that were to be locked.

\$LKWSET_64 (Alpha and Integrity servers)

Lock Pages in Working Set — On Alpha and Integrity server systems, locks a range of virtual addresses in the working set; if the pages are not already in the working set, the service brings them in and locks them. A page locked in the working set does not become a candidate for replacement. This service accepts 64-bit addresses.

Format

```
SYS$LKWSET_64  
    start_va_64 , length_64 , acmode , return_va_64 , return_length_64
```

C Prototype

```
int sys$lkwset_64
```

```
(void *start_va_64, unsigned __int64 length_64, unsigned int acmode,
 void *(*return_va_64), unsigned __int64 *return_length_64);
```

Arguments

start_va_64

OpenVMS usage: address
 type: quadword address
 access: read only
 mechanism: by value

The starting virtual address of the pages to be locked in the working set. The specified virtual address will be rounded down to a CPU-specific page boundary.

length_64

OpenVMS usage: byte count
 type: quadword (unsigned)
 access: read only
 mechanism: by value

Length of the virtual address space to be locked in the working set. The specified length will be rounded up to a CPU-specific page boundary so that it includes all CPU-specific pages in the requested range.

acmode

OpenVMS usage: access_mode
 type: longword (unsigned)
 access: read only
 mechanism: by value

Access mode associated with the pages to be locked. The *acmode* argument is a longword containing the access mode.

The \$PSLDEF macro in STARLET.MLB and the file PSLDEF.H in SYS\$STARLET_C.TLB define the following symbols and their values for the four access modes:

Value	Symbolic Name	Access Mode
0	PSL\$C_KERNEL	Kernel
1	PSL\$C_EXEC	Executive
2	PSL\$C_SUPER	Supervisor
3	PSL\$C_USER	User

The most privileged access mode used is the access mode of the caller. For the \$LKWSET_64 service to complete successfully, the resultant access mode must be equal to or more privileged than the access mode already associated with the pages to be locked.

return_va_64

OpenVMS usage: address
type: quadword address
access: write only
mechanism: by 32- or 64-bit reference

The lowest process virtual address of the pages locked in the working set. The *return_va_64* argument is the 32- or 64-bit virtual address of a naturally aligned quadword into which the service returns the virtual address.

return_length_64

OpenVMS usage: byte count
type: quadword (unsigned)
access: write only
mechanism: by 32- or 64-bit reference

The length of the virtual address range locked in the working set. The *return_length_64* argument is the 32- or 64-bit virtual address of a naturally aligned quadword into which the service returns the length of the virtual address range in bytes.

Description

The Lock Pages in Working Set service locks a range of pages in the working set; if the pages are not already in the working set, it brings them in and locks them. A page locked in the working set does not become a candidate for replacement.

If the condition value *SS\$_ACCVIO* is returned by this service, a value *cannot* be returned in the memory locations pointed to by the *return_va_64* and *return_length_64* arguments. If a condition value other than *SS\$_ACCVIO* is returned, the returned address and returned length indicate the pages that were successfully locked before the error occurred. If no pages were locked, the *return_va_64* argument will contain the value -1, and a value *cannot* be returned in the memory location pointed to by the *return_length_64* argument.

Global pages with write access cannot be locked into the working set.

Be sure to check calls to the *SY\$_LKWSET* and *SY\$_LKWSET_64* system services for correct arguments. This affects only process-based code running above IPL2. Compiler and linker differences might cause your program layout to change from Alpha, resulting in incorrectly calculated starting and ending addresses for calls to *SY\$_LKWSET* and *SY\$_LKWSET_64*. Calling these services with incorrect arguments and then executing this code above IPL2 could cause PGFIPLHI bugchecks. Note that *SY\$_LKWSET* and *SY\$_LKWSET_64* automatically lock linker-generated short data sections associated with code sections locked in the working set.

On Alpha and Integrity server systems, if the first address specified to *SY\$_LKWSET_64* is within an image mapped to your process, a success status indicates that the entire image containing the specified address is locked in the working set. This behavior helps to ensure that privileged processes entering kernel mode and raising IPL higher than IPL 2 do not access an invalid page and cause a PGFIPLHI bugcheck. The system keeps a count of the number of times each image within your process is locked in the working set. This count is maintained so that calls to *SY\$_ULWSET_64* unlock the image only when it has been called the same number of times as *SY\$_LKWSET_64*.

If an attempt to lock an image in the working set returns `SS$_LKWSETFUL`, you might consider moving all kernel mode code within the image to a separate, smaller sharable image. Otherwise, you might consider increasing the working set quota of the process.

The LIBRTL routine `LIB$LOCK_IMAGE` and `LIB$UNLOCK_IMAGE` are preferable to `SYSS$LKWSET_64` and `SYSS$ULKWSET_64` for locking code and related data in the working set. For more information about locking images in the working set, see the LIBRTL manual and the descriptions of `LIB$LOCK_IMAGE` and `LIB$UNLOCK_IMAGE`.

Required Privileges

None.

Required Quota

None.

Related Services

`$LKWSET`, `$ULWSET`, `$ULWSET_64`

Condition Values Returned

`SS$_WASCLR`

The service completed successfully. All of the specified pages were previously unlocked. The entire image might have been locked in the working set.

`SS$_WASSET`

The service completed successfully. At least one of the specified pages was previously locked in the working set. If the image has been locked in the working set, the count of times the image has been locked in the working set has been incremented.

`SS$_ACCVIO`

The *return_va_64* or *return_length_64* argument cannot be written by the caller, or an attempt was made to lock pages by a caller whose access mode is less privileged than the access mode associated with the pages.

`SS$_LKWSETFUL`

The locked working set is full. If any more pages are locked, not enough dynamic pages will be available to continue execution. If the image is being locked in the working set, the image is too large to be entirely locked in the working set.

`SS$_NOPRIV`

No privilege; global pages with write access cannot be locked into the working set.

`SS$_PAGNOTINREG`

A page in the specified range is not within the specified region.

SS\$_PAGOWNVIO

The pages could not be locked because the access mode associated with the call to \$LKWSET_64 was less privileged than the access mode associated with the pages that were to be locked.

\$MGBLSC

Map Global Section — Establishes a correspondence between pages (maps) in the virtual address space of the process and physical pages occupied by a global section.

Format

```
SY$_MGBLSC
  inadr , [retadr] , [acmode] , [flags] , gsdnam , [ident] , [relpag]
```

C Prototype

```
int sys$mgbpsc
  (struct _va_range *inadr, struct _va_range *retadr,
   unsigned int acmode, unsigned int flags, void *gsdnam,
   struct _secid *ident, unsigned int relpag);
```

Arguments

inadr

OpenVMS usage: address_range
type: longword (unsigned)
access: read only
mechanism: by reference

Starting and ending virtual addresses into which the section is to be mapped. The *inadr* argument is the address of a 2-longword array containing, in order, the starting and ending process virtual addresses. Only the virtual page number portion of each virtual address is used to specify which pages are to be mapped; the low-order byte-within-page bits are ignored for this purpose.

The interpretation of the *inadr* argument depends on the setting of SEC\$_EXPREG in the *flags* argument and on whether you are using an Alpha or an Integrity servers system. These system types are discussed separately in this section.

Alpha and Integrity servers System Usage

On Alpha and Integrity server systems, if you do *not* set the SEC\$_EXPREG flag, the *inadr* argument specifies the starting and ending virtual addresses of the region to be mapped. Addresses in system space are not allowed. The addresses must be aligned on CPU-specific pages; no rounding to CPU-specific pages occurs. The lower address of the *inadr* argument must be on a CPU-specific page boundary and the higher address of the *inadr* argument must be 1 less than a CPU-specific boundary, thus forming a range, from lowest to highest, of address bytes. You can use the SY\$_PAGE_SIZE item code in the \$GETSYI system service to set the *inadr* argument to the proper values. You do this to avoid programming errors that might arise because of incorrect programming assumptions about page sizes.

If, on the other hand, you *do* set the `SEC$M_EXPREG` flag, indicating that the mapping should take place using the first available space in a particular region, the *inadr* argument is used only to indicate the desired region: the program region (P0) or the control region (P1).

Caution

Mapping into the P1 region is generally discouraged, but, if done, must be executed with extreme care. Since the user stack is mapped in P1, it is possible that references to the user stack might inadvertently read or write the pages mapped with `$CRMPSC`.

When the `SEC$M_EXPREG` flag is set, the second *inadr* longword is ignored, while bit 30 (the second most significant bit) of the first *inadr* longword is used to determine the region of choice. If the bit is clear, P0 is chosen; if the bit is set, P1 is chosen. On Alpha and Integrity server systems, bit 31 (the most significant bit) of the first *inadr* longword *must be* 0. To ensure compatibility between Alpha and Integrity server systems when you choose a region, VSI recommends that you specify, for the first *inadr* longword, any virtual address in the desired region.

retadr

OpenVMS usage: address_range
type: longword (unsigned)
access: write only
mechanism: by reference

Starting and ending process virtual addresses into which the section was actually mapped by `$MGBLSC`. The *retadr* argument is the address of a 2-longword array containing, in order, the starting and ending process virtual addresses.

On Alpha and Integrity server systems, the *retadr* argument returns the starting and ending addresses of the *usable* range of addresses. This might differ from the total amount mapped. The *retadr* argument is required when the *relpag* argument is specified. If the section being mapped does not completely fill the last page used to map the section, the *retadr* argument indicates the highest address that actually maps the section. If the *relpag* argument is used to specify an offset into the section, the *retadr* argument reflects the offset.

acmode

OpenVMS usage: access_mode
type: longword (unsigned)
access: read only
mechanism: by value

Access mode to be associated with the pages mapped into the process virtual address space. The *acmode* argument is a longword containing the access mode. The `$PSLDEF` macro defines symbols for the four access modes.

The most privileged access mode used is the access mode of the caller.

flags

OpenVMS usage: mask_longword

type: longword (unsigned)
 access: read only
 mechanism: by value

Flag mask specifying options for the operation. The *flags* argument is a longword bit vector wherein a bit when set specifies the corresponding option.

The \$SECDEF macro defines symbolic names for the flag bits. You construct the *flags* argument by specifying the symbolic names of each desired option in a logical OR operation. The following table describes each flag option.

Flag Option	Description
SEC\$_WRT	Map the section with read/write access. By default, the section is mapped with read-only access. If SEC\$_WRT is specified and the section is not copy-on-reference, write access is required.
SEC\$_SYSGBL	Map a system global section. By default, the section is a group global section.
SEC\$_EXPREG	Map the section into the first available virtual address range. By default, the section is mapped into the range specified by the <i>inadr</i> argument. See the <i>inadr</i> argument description for a complete explanation of how to set the SEC\$_EXPREG flag.
SEC\$_UNCACHED	Flag that must be set when a PFN-mapped section is created if this section must be treated as uncached memory. Flag is ignored on Alpha systems; it applies only to Integrity server systems.

gsdnam

OpenVMS usage: section_name
 type: character-coded text string
 access: read only
 mechanism: by descriptor-fixed-length string descriptor

Name of the global section. The *gsdnam* argument is the address of a character string descriptor pointing to this name string.

For group global sections, the operating system interprets the group UIC as part of the global section name; thus, the names of global sections are unique to UIC groups. Further, all global section names are implicitly qualified by their identification fields.

You can specify any name from 1 to 43 characters. All processes mapping to the same global section must specify the same name. Note that the name is case sensitive.

Use of characters valid in logical names is strongly encouraged. Valid values include alphanumeric characters, the dollar sign (\$), and the underscore (_). If the name string begins with an underscore (_), the underscore is stripped and the resultant string is considered to be the actual name. Use of the colon (:) is not permitted.

Names are first subject to a logical name translation, after the application of the prefix GBL\$ to the name. If the result translates, it is used as the name of the section. If the resulting name does not translate, the name specified by the caller is used as the name of the section.

Additional information on logical name translations and on section name processing is available in the *VSI OpenVMS Programming Concepts Manual*.

ident

OpenVMS usage: section_id
 type: quadword (unsigned)
 access: read only
 mechanism: by reference

Identification value specifying the version number of a global section and, for processes mapping to an existing global section, the criteria for matching the identification. The *ident* argument is the address of a quadword structure containing three fields.

The first longword specifies, in the low-order two bits, the matching criteria. Their valid values, the symbolic names by which they can be specified, and their meanings are as follows.

Value/Name	Match Criteria
0 SEC\$K_MATALL	Match all versions of the section.
1 SEC\$K_MATEQU	Match only if major and minor identifications match.
2 SEC\$K_MATLEQ	Match if the major identifications are equal and the minor identification of the mapper is less than or equal to the minor identification of the global section.

The version number is in the second longword and contains two fields: a minor identification in the low-order 24 bits and a major identification in the high-order 8 bits.

If you do not specify *ident* or specify it as the value 0 (the default), the version number and match control fields default to the value 0.

relpag

OpenVMS usage: longword_unsigned
 type: longword (unsigned)
 access: read only
 mechanism: by value

Relative page number within the section of the first page to be mapped. The *relpag* argument is a longword containing this number.

On Alpha and Integrity server systems, the *relpag* argument is interpreted as an index into the section file, measured in pagelets for a file-backed section or CPU-specific pages for a PFN-mapped section.

On Alpha, Integrity servers systems, if you do not specify *relpag* or specify it as the value 0 (the default), the global section is mapped beginning with the first virtual block in a file-backed section or the first CPU-specific page in a PFN-mapped section.

Description

The Map Global Section service establishes a correspondence between pages (maps) in the virtual address space of the process and physical pages occupied by a global section. The protection mask

specified at the time the global section is created determines the type of access (for example, read/write or read only) that a particular process has to the section.

When \$MGBLSC maps a global section, it adds pages to the virtual address space of the process. The section is mapped from a low address to a high address, whether the section is mapped in the program or control region.

If an error occurs during the mapping of a global section, the return address array, if specified, indicates the pages that were successfully mapped when the error occurred. If no pages were mapped, both longwords of the return address array contain the value -1.

Required Access or Privileges

Read access is required. If the SEC\$M_WRT flag is specified, write access is required.

Required Quota

The working set quota (WSQUOTA) of the process must be sufficient to accommodate the increased size of the virtual address space when the \$MGBLSC service maps a section.

If the section pages are copy-on-reference, the process must also have sufficient paging file quota (PGFLQUOTA).

This system service causes the working set of the calling process to be adjusted to the size specified by the working set quota (WSQUOTA). If the working set size of the process is less than quota, the working set size is increased; if the working set size of the process is greater than quota, the working set size is decreased.

Related Services

\$ADJSTK, \$ADJWSL, \$CRETVA, \$CRMPSC, \$DELTVA, \$DGBLSC, \$EXPREG, \$LCKPAG, \$LKWSET, \$PURGWS, \$SETPRT, \$SETSTK, \$SETSWM, \$ULKPAG, \$ULWSET, \$UPDSEC, \$UPDSECW

For more information, see the chapter on memory management in the *VSI OpenVMS Programming Concepts Manual*.

Condition Values Returned

SS\$_NORMAL

The service completed successfully.

SS\$_ACCVIO

The input address array, the global section name or name descriptor, or the section identification field cannot be read by the caller; or the return address array cannot be written by the caller.

SS\$_ENDOFFILE

The starting virtual block number specified is beyond the logical end-of-file.

SS\$_EXQUOTA

The process exceeded its paging file quota, creating copy-on-reference pages.

SS\$_INSFWSL

The working set limit of the process is not large enough to accommodate the increased virtual address space.

SS\$_INVARG

Invalid argument specified to service. Common sources are the incorrect specification of *relpag* or the values in the *inadr* array.

SS\$_IVLOGNAM

The global section name has a length of 0 or has more than 43 characters.

SS\$_IVSECFLG

You set a reserved flag.

SS\$_IVSECIDCTL

The match control field of the global section identification is invalid.

SS\$_NOPRIV

The file protection mask specified when the global section was created prohibits the type of access requested by the caller; or a page in the input address range is in the system address space.

SS\$_NOSHPTS

The region ID of a shared page-table region was specified.

SS\$_NOSUCHSEC

The specified global section does not exist.

SS\$_PAGOWNVIO

A page in the specified input address range is owned by a more privileged access mode.

SS\$_SECREFOVF

The maximum number of references for a global section has been reached (2,147,483,647).

SS\$_TOOMANYLNAM

Logical name translation of the *gsdnam* string exceeded the allowed depth.

SS\$_VA_IN_USE

The existing underlying page cannot be deleted because it is associated with a buffer object.

SS\$_VASFULL

The virtual address space of the process is full; no space is available in the page tables for the pages created to contain the mapped global section.

\$MGBLSC_64 (Alpha and Integrity servers)

Map to Global Section — On Alpha and Integrity server systems, establishes a correspondence between pages in the virtual address space of the process and the pages occupied by a global disk file, page file, or demand-zero section and can map to a demand-zero section with shared page tables. This service accepts 64-bit addresses.

Format

```
SY$MGBLSC_64
  gs_name_64 , ident_64 , region_id_64 , section_offset_64 , length_64
  , acmode , flags , return_va_64 , return_length_64 [, start_va_64]
```

C Prototype

```
int sys$mgbllsc_64
(void *gsdnam_64, struct _secid *ident_64,
 struct _generic_64 *region_id_64, unsigned __int64 section_offset_64,
 unsigned __int64 length_64, unsigned int acmode, unsigned int flags,
 void *(*return_va_64), unsigned __int64 *return_length_64, ...);
```

Arguments

gs_name_64

OpenVMS usage: section_name
type: character-coded text string
access: read only
mechanism: by 32- or 64-bit descriptor–fixed-length string descriptor

Name of the global section. The *gs_name_64* argument is the 32- or 64-bit virtual address of a naturally aligned 32-bit or 64-bit string descriptor pointing to this name string.

You can specify any name from 1 to 43 characters. All processes mapping to the same global section must specify the same name. Note that the name is case sensitive.

Use of characters valid in logical names is strongly encouraged. Valid values include alphanumeric characters, the dollar sign (\$), and the underscore (_). If the name string begins with an underscore (_), the underscore is stripped and the resultant string is considered to be the actual name. Use of the colon (:) is not permitted.

Names are first subject to a logical name translation, after the application of the prefix GBL\$ to the name. If the result translates, it is used as the name of the section. If the resulting name does not translate, the name specified by the caller is used as the name of the section.

Additional information on logical name translations and on section name processing is available in the *VSI OpenVMS Programming Concepts Manual*.

ident_64

OpenVMS usage: section_id
type: quadword (unsigned)

access: read only
 mechanism: by 32- or 64-bit reference

Identification value specifying the version number of a global section. The *ident_64* argument is a quadword containing three fields. The *ident_64* argument is the 32- or 64-bit virtual address of a naturally aligned quadword that contains the identification value.

The first longword specifies the matching criteria in its low-order two bits.

The valid values, symbolic names by which they can be specified, and their meanings are as follows:

Value	Symbolic Name	Match Criteria
0	SEC\$K_MATALL	Match all versions of the section.
1	SEC\$K_MATEQU	Match only if major and minor identifications match.
2	SEC\$K_MATLEQ	Match if the major identifications are equal and the minor identification of the mapper is less than or equal to the minor identification of the global section.

If you specify the *ident_64* argument as 0, the version number and match control fields default to 0.

The version number is in the second longword. The version number contains two fields: a minor identification in the low-order 24 bits and a major identification in the high-order 8 bits. You can assign values for these fields by installation convention to differentiate versions of global sections. If no version number is specified when a section is created, processes that specify a version number when mapping cannot access the global section.

region_id_64

OpenVMS usage: region identifier
 type: quadword (unsigned)
 access: read only
 mechanism: by 32- or 64-bit reference

The region ID associated with the region to map the global section. The file VADEF.H in SYS\$STARLET_C.TLB and the \$VADEF macro in STARLET.MLB define a symbolic name for each of the three default regions in P0, P1, and P2 space.

The following region IDs are defined:

Symbol	Region
VA\$C_P0	Program region
VA\$C_P1	Control region
VA\$C_P2	64-bit program region

Other region IDs, as returned by the \$CREATE_REGION_64 service, can be specified.

section_offset_64

OpenVMS usage: byte offset
 type: quadword (unsigned)

access: read only
 mechanism: by value

Offset into the global section at which to start mapping into the process's virtual address space.

If a map to a global disk file section is being requested, the *section_offset_64* argument specifies an even multiple of disk blocks. If a map to a global page file or demand-zero section is being requested, the *section_offset_64* argument specifies an even multiple of CPU-specific pages. If zero is specified, the global section is mapped beginning with the first page of the section.

If the *region_id_64* argument specifies a shared page table region, *section_offset_64* must be an even multiple of pages mapped by a page table page.

length_64

OpenVMS usage: byte count
 type: quadword (unsigned)
 access: read only
 mechanism: by value

Length, in bytes, of the desired mapping of the global disk file section.

If a map to a global section is being requested, the *length_64* argument must specify an even multiple of disk blocks. If a map to a global page file or demand-zero section is being requested, the *length_64* argument must specify an even multiple of CPU-specific pages. If zero is specified, the size of the disk file is used.

If a shared page-table region is specified by the *region_id_64* argument, *length_64* must be an even multiple of the number of bytes that can be mapped by a CPU-specific page-table page or must include the last page within the memory-resident global section.

acmode

OpenVMS usage: access_mode
 type: longword (unsigned)
 access: read only
 mechanism: by value

Access mode that is to be the owner of the pages created during the mapping. This is also the read access mode and, if the SEC\$M_WRT flag is specified, the write access mode. The *acmode* argument is a longword containing the access mode.

The \$PSLDEF macro in STARLET.MLB and the file PSLDEF.H in SYS\$STARLET_C.TLB define the following symbols and their values for the four access modes:

Value	Symbolic Name	Access Mode
0	PSL\$C_KERNEL	Kernel
1	PSL\$C_EXEC	Executive
2	PSL\$C_SUPER	Supervisor
3	PSL\$C_USER	User

The most privileged access mode used is the access mode of the caller. Address space cannot be created within a region that has a create mode associated with it that is more privileged than the caller's mode. The condition value `SS$_IVACMODE` is returned if the caller is less privileged than the create mode for the region.

flags

OpenVMS usage: mask_longword
 type: longword (unsigned)
 access: read only
 mechanism: by value

Flag mask specifying options for the operation. The *flags* argument is a longword bit vector in which each bit corresponds to a flag. The `$SECDEF` macro and the `SECDEF.H` file define a symbolic name for each flag. You construct the *flags* argument by performing a logical OR operation on the symbol names for all desired flags.

The following table describes each flag that is valid for the `$MGBLSC_64` service.

Flag	Description
<code>SEC\$_EXPREG</code>	Pages are mapped into the first available space at the current end of the specified region. If <code>/ALLOCATE</code> was specified when the memory-resident global section was registered in the Reserved Memory Registry, virtually aligned addresses after the first available space are chosen for the mapping. If the <i>region_id_64</i> argument specifies a shared page-table region, the first available space is round up to the beginning of the next CPU-specific page-table page.
<code>SEC\$_GBL</code>	Pages form a global section. By default, this flag is always present in this service and cannot be disabled.
<code>SEC\$_NO_OVERMAP</code>	Pages cannot overmap existing address space.
<code>SEC\$_SHMGS</code>	On OpenVMS Galaxy systems, create a shared-memory global section.
<code>SEC\$_SYSGBL</code>	The global section map is a system global section. By default, the section is a group global section.
<code>SEC\$_WRT</code>	Map the section with read/write access.

All other bits in the flags argument are reserved for future OpenVMS use and should be specified as 0. The condition value `SS$_IVSECFLG` is returned if any undefined bits are set or if an attempt is made to use the `SEC$_PAGFIL` flag, which applies only to the creation of a page-file backed section.

return_va_64

OpenVMS usage: address
 type: quadword address
 access: write only
 mechanism: by 32- or 64-bit reference

The process virtual address into which the global disk or page file section was mapped. The address.

Upon successful completion of this service, if the *section_offset_64* argument was specified, the virtual address returned in the *return_va_64* argument reflects the offset into the global section mapped such that the virtual address returned cannot be aligned on a CPU-specific page boundary. The virtual address returned will always be on an even virtual disk block boundary.

return_length_64

OpenVMS usage: byte count
type: quadword (unsigned)
access: write only
mechanism: by 32- or 64-bit reference

The length of the usable virtual address range mapped. The *return_length_64* argument is the 32- or 64-bit virtual address of a naturally aligned quadword into which the service returns the length of the virtual address range mapped in bytes.

Upon successful completion of this service, the value in the *return_length_64* argument might differ from the total amount of virtual address space mapped. The value in the *return_va_64* argument plus the value in the *return_length_64* argument indicates the address of the first byte beyond the end of the mapping of the global disk file section.

If the value in the *section_offset_64* argument plus the value in the *length_64* argument did not specify to map the entire global section, this byte can be located at an even virtual disk block boundary within the last page of the mapping.

If the section being mapped does not completely fill the last page used to represent the global disk file section, this byte can be mapped into your address space; however, it is not backed up by the disk file.

start_va_64

OpenVMS usage: address
type: quadword address
access: read only
mechanism: by value

The starting virtual address to which to map the global section. The specified virtual address must be a CPU-specific page-aligned address. If the flag *SEC\$M_EXPREG* is specified, the *start_va_64* argument must not be specified or must be specified as 0. If *SEC\$M_EXPREG* is set and the *start_va_64* argument is nonzero, the condition value *SS\$IVSECFLG* is returned.

If the *region_id_64* argument specifies a shared page-table region, *start_va_64* must be aligned to a CPU-specific page-table page boundary.

Description

The Map to Global Section service establishes a correspondence between pages in the virtual address space of the process and pages occupied by a global disk file, page file, or memory-resident demand-zero section. This service adds pages to the virtual address space of the process.

If a global disk file or page file backed section is being mapped, invalid page table entries are placed in the process page table.

If a memory-resident global section is being mapped, global pages are not charged against the process's working set quota when the virtual memory is referenced and the global pages are not charged against the process's pagefile quota.

If the memory-resident global section was not registered in the Reserved Memory Registry or /NOALLOCATE was specified when the global section was registered, invalid page table entries are placed in the process page table.

If the memory-resident global section was registered in the Reserved Memory Registry and /ALLOCATE was specified when the memory-resident global section was registered, valid page table entries are placed in the process page tables.

If a global disk file or page file backed section is being mapped and the flag SEC\$M_EXPREG is set, the first free virtual address within the specified region is used to start mapping to the global section.

To use the shared page tables associated with a memory-resident global section, you must first create a shared page table region (with SYS\$CREATE_REGION_64). To map to the memory-resident global section using the shared page tables you must do the following:

- Specify a shared page table region in the *region_id_64* argument.
- Specify SEC\$M_WRT in the *flags* argument.
- Set the flag SEC\$M_EXPREG or provide a CPU-specific page-table page-aligned virtual address in the *start_va_64* argument.
- Specify a CPU-specific page-table page-aligned value for the *section_offset_64* argument or zero.
- Specify a value for the *map_length_64* argument that is an even multiple of bytes mapped by a CPU-specific page-table page, or include the last page of the section or zero.

See the description of \$CREATE_REGION_64 for information about calculating virtual addresses that are aligned to a CPU-specific page table page boundary.

A memory-resident global section can be mapped with shared page tables or private page tables. The following table lists the factors associated with determining whether the mapping occurs with shared page tables or private page tables.

Global Section Created with Shared Page Tables	Shared Page-Table Region Specified by <i>region_id_64</i>	Type of Page Tables Used in Mapping
No	No	Private
No	Yes	Private
Yes	No	Private
Yes	Yes	Shared

In general, if the flag SEC\$M_EXPREG is set, the first free virtual address within the specified region is used to map to the global section.

If the flag SEC\$M_EXPREG is set, a memory-resident global section is being mapped and the *region_id_64* argument indicates a shared page-table region, the first free virtual address within the specified region is rounded up to a CPU-specific page-table page boundary and used to map to the global section.

If the flag `SEC$M_EXPREG` is set and the `/ALLOCATE` qualifier was specified with the `SYSMAN` command `RESERVED_MEMORY ADD` for the memory-resident global section, the first free virtual address within the specified region is rounded up to the same virtual alignment as the physical alignment of the preallocated pages and used to map to the global section. Granularity hints are set appropriately for each process private page-table entry (PTE).

In general, if the flag `SEC$M_EXPREG` is clear, the virtual address in the `start_va_64` argument is used to map to the global section.

If the flag `SEC$M_EXPREG` is clear and a memory-resident global section is being mapped, the value specified in the `start_va_64` argument can determine if the mapping is possible and if granularity hints are used in the private page tables. If a shared page-table region is specified by the `region_id_64` argument, the virtual address specified by the `start_va_64` argument must be on an even CPU-specific page-table page boundary or an error is returned by this service. If the `region_id_64` argument does not specify a shared page-table region and the `/ALLOCATE` qualifier was specified with the `SYSMAN` command `RESERVED_MEMORY ADD` for this global section, granularity hints are used only if the virtual alignment of `start_va_64` is appropriate for the use of granularity hints:

- On Alpha systems, granularity hints mean multiples of pages, regardless of page size. The multiples 8, 64, and 512 pages are architected.
- On Integrity server systems, OpenVMS initially supports page sizes of 64KB, 256KB, and 4MB instead of granularity hints. Additional page sizes will be supported in the future.

Whenever granularity hints are being used within the mapping of a memory-resident global section, if the `length_64` argument is not an exact multiple of the alignment factor, lower granularity hints factors are used as appropriate at the higher addressed portion of the global section. If the `section_offset_64` argument is specified, a lower granularity hint factor can be used throughout the mapping of the global section to match the physical alignment of the first page mapped.

If the condition value `SS$_ACCVIO` is returned by this service, a value *cannot* be returned in the memory locations pointed to by the `return_va_64` and `return_length_64` arguments.

If a condition value other than `SS$_ACCVIO` is returned, the returned address and returned length indicate the pages that were successfully mapped before the error occurred. If no pages were mapped, the `return_va_64` argument contains the value `-1`.

Required Privileges

None

Required Quota

If private page tables are used to map to the global section, the working set limit quota (WSQUOTA) of the process must be sufficient to accommodate the increased size of the process page tables required by the increase in virtual address space when the section is mapped.

If private page tables are used to map to a memory-resident global section, the pagefile quota (PGFLQUOTA) of the process must be sufficient to accommodate the increased size of the process page tables required by the increase in virtual address space.

If the process is mapping to a global copy-on-reference section, the pagefile quota (PGFLQUOTA) of the process must be sufficient to accommodate the increased size of the virtual address space.

Related Services

\$CREATE_GDZRO, \$CREATE_GFILE, \$CREATE_GPFILE, \$CREATE_REGION_64, \$CRMPSC_GDZRO_64, \$CRMPSC_GFILE_64, \$CRMPSC_GPFILE_64, \$DELETE_REGION_64, \$DELTVA_64, \$LCKPAG_64, \$LKWSET_64, \$MGBLSC, \$MGBLSC_GPFN_64, \$PURGE_WS, \$SULKPAG_64, \$ULWSET_64, \$UPDSEC_64, \$UPDSEC_64W

Condition Values Returned

SS\$_NORMAL

The service completed successfully.

SS\$_ACCVIO

The *gs_name_64* argument cannot be read by the caller, or the *return_va_64* argument or the *return_length_64* argument cannot be written by the caller.

SS\$_EXPGFLQUOTA

The process's page file quota is not large enough to accommodate the increased virtual address space.

SS\$_GBLSEC_MISMATCH

Global section type mismatch. The specified global section was found; however, it is not a global disk-file, page-file, or demand-zero section.

SS\$_INSFWSL

The process's working set limit is not large enough to accommodate the increased virtual address space.

SS\$_IVACMODE

The specified access mode is greater than PSL\$_USER or the caller's mode is less privileged than the create mode associated with the region. Or, if a shared page table region is specified by the *region_id_64* argument, the *acmode* argument does not match the access mode of the shared PTEs.

SS\$_IVLOGNAM

The specified global section name has a length of 0 or has more than 43 characters.

SS\$_IVREGID

An invalid region ID was specified.

SS\$_IVSECFLG

An invalid flag, a reserved flag, or an invalid combination of flags was specified.

SS\$_IVSECIDCTL

The match control field of the global section identification is invalid.

SS\$_LEN_NOTBLKMULT

The *length_64* argument is not a multiple of virtual disk blocks if a map to a global section was requested (SEC\$_M_PAGFIL is clear in the flags argument).

SS\$_LEN_NOTPAGMULT

The *length_64* argument is not a multiple of CPU-specific pages and a map to a global page file section was requested.

SS\$_NOSHPTS

The region ID of a shared page-table region was specified, and a global section was specified that is not a memory-resident demand-zero section.

SS\$_NOSHPTS

The region ID of a shared page table region was specified.

SS\$_NOSUCHSEC

The specified global section does not exist.

SS\$_OFF_NOTPAGALGN

The *section_offset_64* argument is not CPU-specific page aligned if a map to a global page-file or demand-zero section is requested. Or, if a shared page table region is specified by the *region_id_64* argument, the *section_offset_64* argument is not CPU-specific page-table page aligned.

SS\$_OFFSET_TOO_BIG

The *section_offset_64* argument specified is beyond the logical end-of-file.

SS\$_PAGNOTINREG

A page in the specified input address range is not within the specified region.

SS\$_PAGOWNVIO

A page in the specified input address range already exists and cannot be deleted because it is owned by a more privileged access mode.

SS\$_PROTVIO

The file protection mask specified when the global section was created prohibits the type of access requested by the caller.

SS\$_REGISFULL

The specified virtual region is full; no space is available in the region for the pages created to contain the mapped section.

SS\$_SECREFOVF

The maximum number of references for a global section has been reached (2,147,483,647).

SS\$_SECTBLFUL

There are no entries available in the system global section table.

SS\$_TOOMANYLNAM

The logical name translation of the *gs_name_64* argument exceeded the allowed depth of 10.

SS\$_VA_IN_USE

A page in the specified input address range is already mapped and the flag `SEC$_M_NO_OVERMAP` is set, or a page in the specified input address range is in another region, in system space, or inaccessible; or, the existing underlying page cannot be deleted because it is associated with a buffer object.

SS\$_VA_NOTPAGALGN

The *start_va_64* argument is not CPU-specific page aligned. Or, if a shared page table region is specified by the *region_id_64* argument, the *start_va_64* argument is not CPU-specific page-table page aligned.

SS\$_NOWRTACC

The specified global section is not copy-on-reference and does not allow write access.

\$MGBLSC_GPFN_64 (Alpha and Integrity servers)

Map Global Page Frame Section — On Alpha and Integrity server systems, establishes a correspondence between pages in the virtual address space of the process and the pages occupied by a global page frame section. This service accepts 64-bit addresses.

Format

```
SY$_MGBLSC_GPFN_64
  gs_name_64 , ident_64 , region_id_64 , relative_page , page_count , acmode
  , flags , return_va_64 , return_length_64 [, start_va_64]
```

C Prototype

```
int sys$mgbpsc_gpfm_64
(void *gsdnam_64, struct _secid *ident_64,
 struct _generic_64 *region_id_64, unsigned int relative_page,
 unsigned int page_count, unsigned int acmode, unsigned int flags,
 void *(*return_va_64), unsigned __int64 *return_length_64, ...);
```

Arguments

gs_name_64

OpenVMS usage: section_name

type: character-coded text string
 access: read only
 mechanism: by 32- or 64-bit descriptor–fixed-length string descriptor

Name of the global section. The *gs_name* argument is the 32- or 64-bit virtual address of a naturally aligned 32-bit or 64-bit descriptor pointing to this name string.

You can specify any name from 1 to 43 characters. All processes mapping to the same global section must specify the same name. Note that the name is case sensitive.

Use of characters valid in logical names is strongly encouraged. Valid values include alphanumeric characters, the dollar sign (\$), and the underscore (_). If the name string begins with an underscore (_), the underscore is stripped and the resultant string is considered to be the actual name. Use of the colon (:) is not permitted.

Names are first subject to a logical name translation, after the application of the prefix GBL\$ to the name. If the result translates, it is used as the name of the section. If the resulting name does not translate, the name specified by the caller is used as the name of the section.

Additional information on logical name translations and on section name processing is available in the *VSI OpenVMS Programming Concepts Manual*.

ident_64

OpenVMS usage: section_id
 type: quadword (unsigned)
 access: read only
 mechanism: by 32- or 64-bit reference

Identification value specifying the version number of a global section. The *ident_64* argument is a quadword containing three fields. The *ident_64* argument is the 32- or 64-bit virtual address of a naturally aligned quadword that contains the identification value.

The first longword specifies the matching criteria in its low-order two bits. The valid values, symbolic names by which they can be specified, and their meanings are as follows:

Value	Symbolic Name	Match Criteria
0	SEC\$K_MATALL	Match all versions of the section.
1	SEC\$K_MATEQU	Match only if major and minor identifications match.
2	SEC\$K_MATLEQ	Match if the major identifications are equal and the minor identification of the mapper is less than or equal to the minor identification of the global section.

If you specify the *ident_64* argument as 0, the version number and match control fields default to 0.

The version number is in the second longword. The version number contains two fields: a minor identification in the low-order 24 bits and a major identification in the high-order 8 bits. You can assign values for these fields by installation convention to differentiate versions of global sections. If no version number is specified when a section is created, processes that specify a version number when mapping cannot access the global section.

region_id_64

OpenVMS usage: region identifier
type: quadword (unsigned)
access: read only
mechanism: by 32- or 64-bit reference

The region ID associated with the region to map the private page frame section. The file VADEF.H in SYS\$STARLET_C.TLB and the \$VADEF macro in STARLET.MLB define a symbolic name for each of the three default regions in P0, P1, and P2 space. The following region IDs are defined:

Symbol	Region
VA\$C_P0	Program region
VA\$C_P1	Control region
VA\$C_P2	64-bit program region

Other region IDs, as returned by the \$CREATE_REGION_64 service, can be specified.

relative_page

OpenVMS usage: CPU-specific page count
type: longword (unsigned)
access: read only
mechanism: by value

Relative CPU-specific page number within the global section to start mapping.

page_count

OpenVMS usage: CPU-specific page count
type: longword (unsigned) on Alpha, quadword (unsigned) on Integrity servers
access: read only
mechanism: by value

Length of mapping in CPU-specific pages. If zero is specified, the global page frame section is mapped to the end of the section.

acmode

OpenVMS usage: access-mode
type: longword (unsigned)
access: read only
mechanism: by value

Access mode to be associated with the pages mapped into the process virtual address space. The *acmode* argument is a longword containing the access mode. The \$PSLDEF macro defines symbols for the four access modes.

The most privileged access mode used is the access mode of the caller. Address space cannot be created within a region that has a create mode associated with it that is more privileged than the caller's mode. The condition value `SS$_IVACMODE` is returned if the caller is less privileged than the create mode for the region.

flags

OpenVMS usage: mask_longword
 type: longword (unsigned)
 access: read only
 mechanism: by value

Flag mask specifying options for the operation. The *flags* argument is a longword bit vector in which each bit corresponds to a flag. The `$SECDEF` macro and the `SECDEF.H` file define a symbolic name for each flag. You construct the *flags* argument by performing a logical OR operation on the symbol names for all desired flags.

The following table describes each flag that is valid for the `$MGBLSC_GPFN_64` service:

Flag	Description
<code>SEC\$_ARGS64</code>	Indicates that all parameters, specifically <i>start_pfn</i> and <i>page_count</i> , are passed as 64-bit numbers. This flag is ignored on OpenVMS Alpha but must be set on Integrity server systems. If the flag is not set on Integrity servers, the error code <code>SS\$_IVSECFLG</code> is returned.
<code>SEC\$_GBL</code>	Pages form a global section. By default, this flag is always present in this service and cannot be disabled.
<code>SEC\$_EXPREG</code>	Map the section into the first available space at the current end of the specified region. If this flag is specified, the <i>start_va_64</i> argument is not used.
<code>SEC\$_PERM</code>	Pages are permanent. By default, this flag is always present in this service and cannot be disabled.
<code>SEC\$_PFNMAP</code>	Pages form a page frame section. By default, this flag is always present in this service and cannot be disabled.
<code>SEC\$_PAGFIL</code>	Pages form a global page-file section. <code>SEC\$_PAGFIL</code> also implies <code>SEC\$_WRT</code> and <code>SEC\$_DZRO</code> .
<code>SEC\$_SYSGBL</code>	Map a system global section. By default, the section is a group global section.
<code>SEC\$_UNCACHED</code>	Flag accepted but ignored on Integrity server systems. The cached/uncached characteristic is stored as a section attribute, and the system uses this attribute when the section is mapped. Refer to this flag in the documentation of the <code>SYSCREATE_GPFN</code> system service.
<code>SEC\$_WRT</code>	Map the section with read/write access. By default, the section is mapped with read-only access. If <code>SEC\$_WRT</code> is specified, write access is required.

All other bits in the *flags* argument are reserved for future OpenVMS use and should be specified as 0. The condition value `SS$_IVSECFLG` is returned if any undefined bits are set or if an illegal combination of flags is set.

return_va_64

OpenVMS usage: address
type: quadword address
access: write only
mechanism: by 32- or 64-bit reference

The lowest process virtual address into which the global page frame section was mapped. The *return_va_64* argument is the 32- or 64-bit virtual address of a naturally aligned quadword that contains the virtual address.

return_length_64

OpenVMS usage: byte count
type: quadword (unsigned)
access: write only
mechanism: by 32- or 64-bit reference

The 32- or 64-bit virtual address of a naturally aligned quadword into which the \$MGBLSC_GPFN_64 service returns the length of the virtual address range in bytes.

start_va_64

OpenVMS usage: address
type: quadword address
access: read only
mechanism: by value

The starting virtual address to map the global section. The specified virtual address must be a CPU-specified page-aligned address. If the flag SEC\$M_EXPREG is specified, the *start_va_64* argument must not be specified or must be specified as 0. If SEC\$M_EXPREG is set and the *start_va_64* argument is nonzero, the condition value SSS_IVSECFLG is returned.

Always refer to the *return_va_64* and *return_length_64* arguments to determine the range of virtual addresses mapped.

Description

The Map Global Page Frame Section service establishes a correspondence between pages in the virtual address space of the process and pages occupied by a global page frame section. It adds pages to the virtual address space of the process.

Pages mapped to a global page frame section are not included in or charged against the process's working set; they are always valid. Do not lock these pages in the working set by using \$LKWSET; this can result in a machine check if they are in I/O space.

If the condition value SSS_ACCVIO is returned by this service, a value *cannot* be returned in the memory locations pointed to by the *return_va_64* and *return_length_64* arguments.

If a condition value other than SSS_ACCVIO is returned, the returned address and returned length indicate the pages that were successfully mapped before the error occurred. If no pages were mapped,

the *return_va_64* argument will contain the value -1, and a value *cannot* be returned in the memory location pointed to by the *return_length_64* argument.

Required Privileges

Read access is required. If the SEC\$M_WRT flag is specified, write access is required.

Required Quota

The working set quota (WSQUOTA) of the process must be sufficient to accommodate the increased length of the process page table required by the increase in virtual address space.

The page file quota (PAGFLQUOTA) of the process must be sufficient to accommodate the increased number of process page tables required by the increase in virtual address space. (Note that this service can return the SS\$_EXPGFLQUOTA.)

Related Services

\$CREATE_GPFN, \$CREATE_REGION_64, \$CRMPSC_GPFN_64, \$DELETE_REGION_64, \$DELTVA_64, \$MGBLSC, \$MGBLSC_64

Condition Values Returned

SS\$_NORMAL

The service completed successfully.

SS\$_ACCVIO

The *gs_name_64* argument cannot be read by the caller, or the *return_va_64* or *return_length_64* argument cannot be written by the caller.

SS\$_GBLSEC_MISMATCH

Global section type mismatch. The specified global section was found; however, it is not a global page frame section.

SS\$_ILLRELPAG

The specified relative page argument is either larger than the highest page number within the section or is not a valid 32-bit physical page frame number.

SS\$_INSFWSL

The working set limit of the process is not large enough to accommodate the increased virtual address space.

SS\$_IVACMODE

The caller's mode is less privileged than the create mode associated with the region.

SS\$_IVLOGNAM

The specified global section name has a length of 0 or has more than 43 characters.

SS\$_IVREGID

Invalid region ID specified.

SS\$_IVSECFLG

An invalid flag, a reserved flag, or an invalid combination of flags was specified.

SS\$_IVSECIDCTL

The match control field of the global section identification is invalid.

SS\$_NOSUCHSEC

The specified global section does not exist.

SS\$_NOWRTACC

The specified global section is not copy-on-reference and does not allow write access.

SS\$_PROTVIO

The file protection mask specified when the global section was created prohibits the type of access requested by the caller.

SS\$_PAGNOTINREG

A page in the specified range is not within the specified region.

SS\$_PAGOWNVIO

A page in the specified range already exists and cannot be deleted because it is owned by a more privileged access mode than that of the caller.

SS\$_REGISFULL

The specified virtual region is full; no space is available in the region for the pages created to contain the mapped global section.

SS\$_TOOMANYLNAM

The logical name translation of the *gs_name_64* argument exceeded the allowed depth of 10.

SS\$_VA_IN_USE

The existing underlying page cannot be deleted because it is associated with a buffer object.

SS\$_VA_NOTPAGALGN

The *start_va_64* argument is not CPU-specific page aligned.

\$MOD HOLDER

Modify Holder Record in Rights Database — Modifies the specified holder record of the target identifier in the rights database.

Format

```
SYS$MOD HOLDER id ,holder , [set_attrib] , [clr_attrib]
```

C Prototype

```
int sys$mod_holder  
    (unsigned int id, struct _generic_64 *holder, unsigned int set_attrib,  
     unsigned int clr_attrib);
```

Arguments

id

OpenVMS usage: rights_id
type: longword (unsigned)
access: read only
mechanism: by value

Binary value of target identifier whose holder record is modified when \$MOD_HOLDER completes execution. The *id* argument is a longword containing the identifier value.

holder

OpenVMS usage: rights_holder
type: quadword (unsigned)
access: read only
mechanism: by reference

Identifier of holder being modified when \$MOD_HOLDER completes execution. The *holder* argument is the address of a quadword containing the UIC identifier of the holder in the first longword and the value of 0 in the second longword.

set_attrib

OpenVMS usage: mask_longword
type: longword (unsigned)
access: read only
mechanism: by value

Bit mask of attributes to be enabled for the identifier when \$MOD_HOLDER completes execution. The *set_attrib* argument is a longword containing the attribute mask.

The attributes actually enabled are the intersection of those specified and the attributes of the identifier. If you specify the same attribute in *set_attrib* and *clr_attrib*, the attribute is enabled.

Symbol values are offsets to the bits within the longword. You can also obtain the values as masks with the appropriate bit set using the prefix KGB\$M rather than KGB\$V. The following symbols for each bit position are defined in the system macro library (\$KGBDEF).

Bit Position	Meaning When Set
KGB\$V_DYNAMIC	Allows holders of the identifier to remove it from or add it to the process rights list by using the DCL command SET RIGHTS_LIST.
KGB\$V_NOACCESS	Makes any access rights of the identifier null and void. This attribute is intended as a modifier for a resource identifier or the Subsystem attribute.
KGB\$V_RESOURCE	Allows the holder to charge resources, such as disk blocks, to the identifier.
KGB\$V_SUBSYSTEM	Allows holders of the identifier to create and maintain protected subsystems by assigning the Subsystem ACE to the application images in the subsystem.

clr_attrib

OpenVMS usage: mask_longword
type: longword (unsigned)
access: read only
mechanism: by value

Bit mask of attributes to be disabled for the identifier when \$MOD_HOLDER completes execution. The *clr_attrib* argument is a longword containing the attribute mask.

If you specify the same attribute in *set_attrib* and *clr_attrib*, the attribute is enabled.

Symbol values are offsets to the bits within the longword. You can also obtain the values as masks with the appropriate bit set using the prefix KGB\$M rather than KGB\$V. The following symbols for each bit position are defined in the system macro library (\$KGBDEF).

Bit Position	Meaning When Set
KGB\$V_DYNAMIC	Allows holders of the identifier to remove it from or add it to the process rights list by using the DCL command SET RIGHTS_LIST.
KGB\$V_NOACCESS	Makes any access rights of the identifier null and void. This attribute is intended as a modifier for a resource identifier or the Subsystem attribute.
KGB\$V_RESOURCE	Allows the holder to charge resources, such as disk blocks, to the identifier.
KGB\$V_SUBSYSTEM	Allows holders of the identifier to create and maintain protected subsystems by assigning the Subsystem ACE to the application images in the subsystem.

Description

The Modify Holder Record in Rights Database service modifies the specified holder record in the rights database. Identifier attributes can be added or removed.

When you specify both the *set_attrib* and *clr_attrib* arguments, the attribute is cleared first. Thus, if you specify the same attribute bit with each argument, the result is that the bit is set.

Required Access or Privileges

Write access to the rights database is required.

Required Quota

None

Related Services

\$ADD HOLDER, \$ADD_IDENT, \$ASCTOID, \$CREATE_RDB, \$FIND_HELD, \$FIND HOLDER, \$FINISH_RDB, \$GET_SECURITY, \$GRANTID, \$IDTOASC, \$MOD_IDENT, \$REM HOLDER, \$REM_IDENT, \$REVOKEID, \$SET_SECURITY

Condition Values Returned

SS\$_NORMAL

The service completed successfully.

SS\$_ACCVIO

The *holder* argument cannot be read by the caller.

SS\$_BADPARAM

The specified attributes contain invalid attribute flags.

SS\$_INSFMEM

The process dynamic memory is insufficient for opening the rights database.

SS\$_IIDENT

The specified identifier or holder identifier is of invalid format.

SS\$_NOSUCHID

The specified identifier does not exist in the rights database, or the specified holder identifier does not exist in the rights database.

RMS\$_PRV

The user does not have write access to the rights database.

Because the rights database is an indexed file accessed with OpenVMS RMS, this service can also return RMS status codes associated with operations on indexed files. For descriptions of these status codes, refer to the *VSI OpenVMS Record Management Services Reference Manual*.

\$MOD_IDENT

Modify Identifier in Rights Database — Modifies the specified identifier record in the rights database.

Format

```
SY$MOD_IDENT id , [set_attrib] , [clr_attrib] , [new_name] , [new_value]
```

C Prototype

```
int sys$mod_ident  
    (unsigned int id, unsigned int set_attrib, unsigned int clr_attrib,
```

```
void *new_name, unsigned int new_value);
```

Arguments

id

OpenVMS usage: `rights_id`
 type: `longword (unsigned)`
 access: `read only`
 mechanism: `by value`

Binary value of identifier whose identifier record is modified when `$MOD_IDENT` completes execution. The `id` argument is a longword containing the identifier value.

set_attrib

OpenVMS usage: `mask_longword`
 type: `longword (unsigned)`
 access: `read only`
 mechanism: `by value`

Bit mask of attributes to be enabled for the identifier when `$MOD_IDENT` completes execution. The `set_attrib` argument is a longword containing the attribute mask.

The attributes actually enabled are the intersection of those specified and the attributes of the identifier. If you specify the same attribute in `set_attrib` and `clr_attrib`, the attribute is enabled.

Symbol values are offsets to the bits within the longword. You can also obtain the values as masks with the appropriate bit set using the prefix `KGB$M` rather than `KGB$V`. The following symbols for each bit position are defined in the system macro library (`$KGBDEF`).

Bit Position	Meaning When Set
<code>KGB\$V_DYNAMIC</code>	Allows holders of the identifier to remove it from or add it to the process rights list by using the DCL command <code>SET_RIGHTS_LIST</code> .
<code>KGB\$V HOLDER_HIDDEN</code>	Prevents someone from getting a list of users who hold an identifier, unless they own the identifier themselves.
<code>KGB\$V_NAME_HIDDEN</code>	Allows holders of an identifier to have it translated – either from binary to ASCII or vice versa – but prevents unauthorized users from translating the identifier.
<code>KGB\$V_NOACCESS</code>	Makes any access rights of the identifier null and void. This attribute is intended as a modifier for a resource identifier or the Subsystem attribute.
<code>KGB\$V_RESOURCE</code>	Allows holders of an identifier to charge disk space to the identifier. It is used only for file objects.
<code>KGB\$V_SUBSYSTEM</code>	Allows holders of the identifier to create and maintain protected subsystems by assigning the Subsystem ACE to the application images in the subsystem.

clr_attrib

OpenVMS usage: mask_longword
 type: longword (unsigned)
 access: read only
 mechanism: by value

Bit mask of attributes to be disabled for the identifier when \$MOD_IDENT completes execution. The *clr_attrib* argument is a longword containing the attribute mask.

If you specify the same attribute in *set_attrib* and *clr_attrib*, the attribute is enabled.

Symbol values are offsets to the bits within the longword. You can also obtain the values as masks with the appropriate bit set using the prefix KGB\$M rather than KGB\$V. The following symbols for each bit position are defined in the system macro library (\$KGBDEF).

Bit Position	Meaning When Set
KGB\$V_DYNAMIC	Allows holders of the identifier to remove it from or add it to the process rights list by using the DCL command SET_RIGHTS_LIST.
KGB\$V HOLDER_HIDDEN	Prevents someone from getting a list of users who hold an identifier, unless they own the identifier themselves.
KGB\$V_NAME_HIDDEN	Allows holders of an identifier to have it translated – either from binary to ASCII or vice versa – but prevents unauthorized users from translating the identifier.
KGB\$V_NOACCESS	Makes any access rights of the identifier null and void. This attribute is intended as a modifier for a resource identifier or the Subsystem attribute.
KGB\$V_RESOURCE	Allows holders of an identifier to charge disk space to the identifier. It is used only for file objects.
KGB\$V_SUBSYSTEM	Allows holders of the identifier to create and maintain protected subsystems by assigning the Subsystem ACE to the application images in the subsystem.

new_name

OpenVMS usage: char_string
 type: character-coded text string
 access: read only
 mechanism: by descriptor—fixed-length string descriptor

New name to be given to the specified identifier. The *new_name* argument is the address of the descriptor pointing to the identifier name string.

An identifier name consists of 1 to 31 alphanumeric characters, including dollar signs (\$) and underscores (_), and must contain at least one nonnumeric character. Any lowercase characters specified are automatically converted to uppercase.

new_value

OpenVMS usage: rights_id
type: longword (unsigned)
access: read only
mechanism: by value

New value to be assigned to the specified identifier. The *new_value* argument is a longword containing the binary value of the specified identifier. When the identifier value is changed, \$MOD_IDENT also changes the value of the identifier in all of the holder records in which the specified identifier appears.

Description

The Modify Identifier in Rights Database service modifies the specified identifier record in the rights database. Identifier attributes can be added or removed. The identifier name or value can be changed. When you specify both the *set_attrib* and *clr_attrib* arguments, the attribute is cleared first. Thus, if you specify the same attribute bit with each argument, the result is that the bit is set.

Required Access or Privileges

Write access to the rights database is required.

Required Quota

None

Related Services

\$ADD HOLDER, \$ADD_IDENT, \$ASCTOID, \$CREATE_RDB, \$FIND_HELD, \$FIND HOLDER, \$FINISH_RDB, \$GRANTID, \$IDTOASC, \$MOD HOLDER, \$REM HOLDER, \$REM_IDENT, \$REVOKID

Condition Values Returned

SS\$_NORMAL

The service completed successfully.

SS\$_NOSUCHID

The specified identifier does not exist in the rights database.

SS\$_BADPARAM

The specified attributes contain invalid attribute flags.

SS\$_DUPIDENT

The specified identifier value already exists.

SS\$_DUPLNAM

The specified identifier name already exists in the rights database.

SS\$_INSFMEM

The process dynamic memory is insufficient for opening the rights database.

SS\$_IIDENT

The specified identifier is of invalid format.

RMS\$_PRV

The user does not have write access to the rights database.

Because the rights database is an indexed file accessed with OpenVMS RMS, this service can also return RMS status codes associated with operations on indexed files. For descriptions of these status codes, refer to the *VSI OpenVMS Record Management Services Reference Manual*.

\$MOUNT

Mount Volume — Mounts a tape, disk volume, or volume set and specifies options for the mount operation.

Format

```
SYS$MOUNT itmlst
```

C Prototype

```
int sys$mount (void *itmlst);
```

Argument

itmlst

OpenVMS usage: item_list_3
 type: longword (unsigned)
 access: read only
 mechanism: by reference

Item list specifying options for the mount operation. The *itmlst* argument is the address of a list of item descriptors, each of which specifies an option and provides the information needed to perform the operation.

The item list must include at least one device item descriptor and is terminated by a longword value of 0.

The following diagram depicts the format of a single item descriptor.

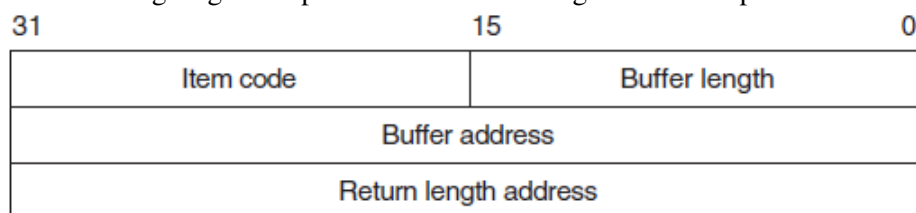

ZK-5186A-GE

The following table defines the item descriptor fields.

Descriptor Field	Definition
Buffer length	A word specifying the length (in bytes) of the buffer that supplies the information \$MOUNT needs to process the specified item code. The required length of the buffer depends on the item code specified in the item code field of the item descriptor. If the value of the buffer length is too small, \$MOUNT truncates the data.
Item code	A word containing a user-supplied symbolic code that specifies an option for the MOUNT operation. The \$MNTDEF macro defines these codes.
Buffer address	A longword containing the address of the buffer that supplies information to \$MOUNT.
Return length address	This field is not used.

Item Codes

MNT\$_ACCESSED

The MNT\$_ACCESSED item code specifies the number of directories that will be in use, concurrently, on the volume. The buffer must contain a longword integer value in the range 0 to 255. This value overrides the number of directories specified when the volume was initialized. To specify MNT\$_ACCESSED, the caller must have OPER privilege. The MNT\$_ACCESSED item code applies only to disks.

MNT\$_BLOCKSIZE

The MNT\$_BLOCKSIZE item code specifies the default block size for tape volumes. The buffer must contain a longword integer value in the range 20 to 65,532 bytes for OpenVMS RMS operations or 10 to 65,534 bytes for operations that do not use RMS. The MNT\$_BLOCKSIZE item code applies only to tapes.

If you do not specify MNT\$_BLOCKSIZE, the default block size is 2048 bytes for Files-11 tape volumes and 512 bytes for foreign and unlabeled tapes.

You must specify MNT\$_BLOCKSIZE when mounting (1) tapes that do not have ANSI HDR2 labels, (2) tapes to which data will be written from compatibility mode, and (3) tapes that are to contain records whose size is larger than the default value.

MNT\$_COMMENT

The MNT\$_COMMENT item code specifies text to be associated with an operator request. The buffer must contain a character string of no more than 78 characters. This text will be printed on the operator's console if an operator request is issued for the device being mounted.

MNT\$_DATA

Specifies the Extended File Cache (XFC) to be enabled on the disk. To specify MNT\$_DATA, you require OPER privilege. This is the default unless the NOQUOTA, NOFILEID, NOEXTENT, and WRITETHROUGH qualifiers are all specified with the MOUNT command.

MNT\$_DENSITY

The MNT\$_DENSITY item code specifies

the density at which data is to be written to a foreign or unlabeled tape. The DENSITY item code supplied is dependent on the type of tape device. If a tape device is capable of using the MT3 density codes, the buffer for the MNT\$_DENSITY item code must contain a longword with one of the MT3 codes, as defined in SYS\$LIBRARY:STARLET (MT3\$_TK_50, MT3\$_K_3480, MT3\$_K_SDLT, MT3\$_K_AIT2, and so on). Refer to the MT3_SUPPORTED argument for \$GETDVI.

If the device does not support MT3 densities, the buffer must contain a longword value that specifies one of the following legal densities: 800 bpi, 1600 bpi, or 6250 bpi.

The specified density will be used only if (1) the tape is foreign or unlabeled and (2) the first operation is a write.

MNT\$_DEVNAM

The MNT\$_DEVNAM item code specifies the name of the device to be mounted. The buffer must contain a character string of from 1 to 64 characters, which is the device name. The device name can be a physical device name or a logical name; if it is a logical name, it must translate to a physical device name.

The MNT\$_DEVNAM item code must appear at least once in an item list, and it can appear more than once. It appears more than once when a volume set is being mounted, because, in this case, one device is being mounted for each volume in the volume set.

MNT\$_EXTENSION

The MNT\$_EXTENSION item code specifies the number of blocks by which files will be extended. The buffer must contain a longword value in the range 0 to 65,535. The MNT\$_EXTENSION item code applies only to disks.

MNT\$_EXTENT

The MNT\$_EXTENT item code specifies the size of the extent cache in units of extent pointers. The buffer must contain a longword value, which specifies this size. To specify MNT\$_EXTENT, you need OPER privilege. The value 0 (the default) disables caching. The MNT\$_EXTENT item code applies only to disks.

MNT\$_FILEID

The MNT\$_FILEID item code specifies the size of the file-ID cache in units of file numbers. The buffer must contain a longword value, which specifies this size. To specify MNT\$_FILEID, you need OPER privilege. The value 1 disables caching. The MNT\$_FILEID item code applies only to disks.

MNT\$_FLAGS

The MNT\$_FLAGS item code specifies a 2-longword bit vector wherein each bit specifies an option for the mount operation. The buffer must contain a quadword, which is the bit vector.

The \$MNTDEF macro defines symbolic names for each option (bit) in the bit vector. You construct the bit vector by specifying the symbolic names for the desired options in a logical OR operation. In the first longword you logically OR the MNT\$_M_ mask bits, and in the second longword you logically

OR the MNT2\$M_ mask bits. The following table describes the symbolic names for each option. The MNT2\$M_ options are at the end of the table.

Option	Description
MNT\$M_CLUSTER	<p>The volume is to be mounted for clusterwide access; that is, every OpenVMS Cluster node can access the volume. \$MOUNT mounts the volume first on the caller's node and then on every other node in the existing cluster.</p> <p>Only system or group volumes can be mounted clusterwide. If you do not specify MNT\$M_GROUP or MNT\$M_SYSTEM, \$MOUNT mounts the volume as a system volume, provided the caller has SYSNAM privilege. To mount a group volume clusterwide, the caller must have GRPNAM privilege. To mount a system volume clusterwide, the caller must have SYSNAM privilege.</p> <p>MNT\$M_CLUSTER has no effect if the system is not a member of a cluster. MNT\$M_CLUSTER applies only to disks.</p>
MNT\$M_FOREIGN	<p>The volume is to be mounted as a foreign volume; a foreign volume is not Files-11 structured. If you specify MNT\$M_FOREIGN, the following item codes can each appear in the item list only once: the caller must either own the volume or have VOLPRO privilege.</p>
MNT\$M_GROUP	<p>The logical name for the volume to be mounted is entered in the group logical name table, and the volume is made accessible to other users with the same UIC group number as that of the calling process. To specify MNT\$M_GROUP, the caller must have GRPNAM privilege. MNT\$M_GROUP applies only to disks.</p>
MNT\$M_INCLUDE	<p>Automatically reconstructs a shadow set to the state it was in before the shadow set was dissolved (due to dismounting or system failure). Use this option to mount a shadow set or a volume set of shadow sets. You must specify the exact name of the original virtual unit and the device name of at least one of the shadow set members. The shadowing software reads the shadow set membership information from the named device to determine the membership of the original shadow set. You can include the MNT\$M_INCLUDE option in executable images to have a shadow set reconstructed. Using MNT\$M_INCLUDE prevents your having to manually reinstate shadow sets after they have been dismounted.</p> <p>If you do not select this option, \$MOUNT does not automatically reconstruct the former shadow set.</p>
MNT\$M_INIT_CONT	<p>Additional volumes in the volume set are to be initialized without operator intervention. \$MOUNT initializes new volumes with the protections specified for the first magnetic tape of the volume set and creates unique volume label names for up to 99 volumes in a volume set.</p>

Option	Description
	<p>If MNT\$M_INIT_CONT is specified, you must allocate multiple magnetic tape drives to the volume set. If \$MOUNT switches to a drive that has no magnetic tape loaded or has the wrong magnetic tape loaded or if \$MOUNT tries to read a magnetic tape that is not loaded, it notifies the operator to load the correct magnetic tape. \$MOUNT will dismount and unload volumes as soon as they have been read or written. The operator can load the next volume in the volume set before the current reel of the volume set reaches the end of the magnetic tape.</p> <p>If writing to the volume set, \$MOUNT automatically (1) switches to the next magnetic tape drive, (2) initializes that magnetic tape with the same volume name and protection as specified in the volume labels of the first volume in the set, and (3) notifies the operator that the switch has occurred. If reading the volume set, \$MOUNT generates the label for the next volume in the volume set and reads that volume.</p> <p>The label name that \$MOUNT generates for each additional volume in the volume set consists of six characters: the first four characters are the same as the first four characters of the label name of the previous volume; the fifth and sixth characters represent the number of the volume in the volume set.</p> <p>MNT\$M_INIT_CONT applies only to magnetic tapes.</p>
MNT\$M_MESSAGE	Messages will be sent to the caller's SYS\$OUTPUT device.
MNT\$M_MINICOPY_OPTIONAL	\$MOUNT fails if minicopy has not been enabled on the disk.
MNT\$M_MULTI_VOL	<p>Specifies, for foreign or unlabeled magnetic tapes, that subsequent volumes can be processed by overriding MOUNT's access checks. You can use this option when a utility that supports multivolume magnetic tape sets needs to process subsequent volumes, and these volumes do not contain labels that MOUNT can interpret. You need VOLPRO privilege to specify the MNT\$M_MULTI_VOL option. MNT\$M_MULTI_VOL can only be used with the MNT\$M_FOREIGN option.</p> <p>VSI recommends the use of this qualifier only when it is not possible to alter the utility to explicitly perform MOUNT and DISMOUNT operations on each reel in the set.</p>
MNT\$M_NOASSIST	\$MOUNT does not request operator assistance if errors are encountered during the mount operation. If not specified, \$MOUNT requests operator assistance to recover from some error conditions.
MNT\$M_NOAUTO	Automatic volume labeling (AVL) and automatic volume recognition (AVR) are to be disabled. If MNT\$M_NOAUTO is specified, the operator must enter commands from the console to process each additional volume in a volume set. When a volume is finished processing, the operator

Option	Description
	<p>specifies the drive on which the next volume is loaded and the label name of the next volume. You might want to use MNT\$M_NOAUTO to disable AVL and AVR when not reading a volume set sequentially.</p> <p>You can enable AVL and AVR by specifying MNT\$M_INIT_CONT. MNT\$M_NOAUTO applies only to magnetic tapes.</p>
MNT\$M_NOCACHE	<p>All caching associated with the volume is turned off. Specifying MNT\$M_NOCACHE is equivalent to (1) specifying MNT\$M_WRITETHRU, (2) specifying a value of 1 for the item descriptor MNT\$_FILEID, and (3) specifying a value of 0 for the item descriptors MNT\$M_EXTENT and MNT\$M_QUOTA.</p>
MNT\$M_NOCOPY	<p>Disables full copy operations on all physical devices being mounted or added to a shadow set. This option provides you with the opportunity to confirm the states of all of the devices or members of a shadow set before proceeding with any full copy operation. This prevents any accidental loss of data that could occur if an unintended device is added to the shadow set.</p> <p>If you do not select this option, \$MOUNT automatically overwrites the data on shadow set members that are not current. When you select this option, a \$MOUNT operation fails if any of the specified potential shadow set members require full copy operations.</p>
MNT\$M_NODISKQ	<p>Disk quotas are not to be enforced for the volume to be mounted. If not specified, disk quotas are enforced. To specify MNT\$M_NODISKQ, the caller must either own the volume or have VOLPRO privilege. MNT\$M_NODISKQ applies only to disks.</p>
MNT\$M_NOHDR3	<p>ANSI HDR3 and HDR4 labels are not to be written to magnetic tapes as they are mounted. If not specified, ANSI HDR3 and HDR4 labels are written to all tapes.</p> <p>Use MNT\$M_NOHDR3 when writing to volumes that will be read by a system, such as the RT-11 system, which does not process HDR3 and HDR4 labels correctly. MNT\$M_NOHDR3 applies only to tapes.</p>
MNT\$M_NOLABEL	<p>The volume is to be mounted as a foreign volume; a foreign volume is not Files-11 structured. If you specify MNT\$M_NOLABEL, the following item codes can each appear in the item list only once: MNT\$_DEVNAM, MNT\$_VOLNAM, and MNT\$_LOGNAM. To specify MNT\$M_NOLABEL, the caller must either own the volume or have VOLPRO privilege.</p>

Option	Description
MNT\$M_NOMNTVER	The volume is not marked as a candidate for automatic mount verification. If not specified, the volume is marked as a candidate for mount verification.
MNT\$M_NOREBUILD	<p>The volume to be mounted should be returned to active use immediately, without performing a rebuild operation. This flag defers the disk rebuild operation, so that the volume to be mounted is returned to active use immediately. A rebuild operation can consume a considerable amount of time, depending on the number of files on the volume and on the number of different file owners (if quotas are in use). The volume can be rebuilt later with the DCL command SET VOLUME/REBUILD to recover the free space; for more information, see the <i>VSI OpenVMS DCL Dictionary</i>.</p> <p>If a disk volume is improperly dismounted, for example, during a system failure, it must be rebuilt to recover any caching limits that were enabled on the volume at the time of the dismount. By default, \$MOUNT attempts to rebuild.</p> <p>When mounting a volume set, you must mount all members of the set to reclaim all available free space.</p> <p>MNT\$M_NOREBUILD applies only to disks.</p>
MNT\$M_NOUNLOAD	The volume to be mounted is not to be unloaded when it is dismounted. Specifying MNT\$M_NOUNLOAD causes the volume to remain loaded when it is dismounted unless the dismount explicitly requests that the volume be unloaded.
MNT\$M_NOWRITE	The volume to be mounted is software write locked. If not specified, the volume is assumed to have read and write access.
MNT\$M_OVR_ACCESS	<p>If the installation allows, this option overrides any character in the accessibility field of the volume. The necessity of this option is defined by the installation. That is, each installation has the option of specifying a routine that the magnetic tape file system will use to process this field. By default, the operating system provides a routine that checks this field in the following manner:</p> <ul style="list-style-type: none"> • If the magnetic tape was created on a version of the operating system that conforms to Version 3 of ANSI, then you must use this option to override any character other than an ASCII space. • If a protection is specified and that magnetic tape conforms to an ANSI standard that is higher than Version 3, then you must use this option to override any character other than an ASCII 1.

Option	Description
	To specify MNT\$M_OVR_ACCESS, the caller must either own the volume or have VOLPRO privilege. MNT\$M_OVR_ACCESS applies only to tapes.
MNT\$M_OVR_EXP	A tape that has not yet reached its expiration date can be overwritten. To specify MNT\$M_OVR_EXP, the caller must own the volume or have VOLPRO privilege.
MNT\$M_OVR_IDENT	You can mount the volume without specifying the volume name (by using the MNT\$_VOLNAM item code). If specified, the following options must not be specified: MNT\$M_CLUSTER, MNT\$M_GROUP, MNT\$M_SHARE, and MNT\$M_SYSTEM.
MNT\$M_OVR_LOCK	The software write lock that occurs when a volume has a corrupted storage bit mask can be overridden.
MNT\$M_OVR_SETID	Checks on the volume set identification are not to be performed when subsequent reels in the volume set are mounted. MNT\$M_OVR_SETID applies only to tapes.
MNT\$M_OVR_SHAMEM	<p>Allows you to mount former shadow set members outside of the shadow set. If you do not specify this option, \$MOUNT automatically mounts the volume write-locked to prevent accidental deletion of data. To specify this option, you must either own the volume or have VOLPRO privilege.</p> <p>When you use this option, the shadow set generation number is erased from the volume. If you then remount the volume in the former shadow set, \$MOUNT considers it an unrelated volume and marks it for a full copy operation.</p>
MNT\$M_OVR_VOLO	<p>The volume label's owner identifier field is not to be processed. \$MOUNT reads volume owner and protection information from the volume owner field of the volume labels.</p> <p>The operating system requires that you specify MNT\$M_OVR_VOLO to process magnetic tapes when all of the following conditions exist: (1) the volume was created on an operating system other than OpenVMS; (2) the volume was initialized with a protection specified; and (3) the volume conforms to the Version 3 ANSI label standard.</p> <p>To specify MNT\$M_OVR_VOLO, the caller must either have VOLPRO privilege or own the volume. MNT\$M_OVR_VOLO applies only to tapes.</p>
MNT\$M_READCHECK	Read checks are to be performed following all read operations.
MNT\$M_REQUIRE_MEMBERS	Controls whether every physical device specified with the MEMBERS /SHADOW qualifier must be accessible when the MOUNT command is issued in order for the \$MOUNT system service to take effect.

Option	Description
MNT\$M_SHARE	<p>Volume is to be mounted shared and is therefore accessible to other users. MNT\$M_SHARE applies only to disks.</p> <p>If the volume was previously mounted shared by another user and MNT\$M_SHARE is specified in the current call, all other options specified in the current call are ignored.</p> <p>If the caller allocated the device and specified MNT\$M_SHARE in the call to \$MOUNT, \$MOUNT will deallocate the device so that other users can access the volume.</p>
MNT\$M_SYSTEM	<p>The logical name for the volume to be mounted is entered in the system logical name table, and the volume is made accessible to all other users, provided that UIC-based protection allows access to the volume. To specify MNT\$M_SYSTEM, the caller must have SYSNAM privilege. MNT\$M_SYSTEM applies only to disks.</p>
MNT\$M_TAPE_DATA_WRITE	<p>Enables the tape controller's write cache for this device. Enabling the write cache improves data throughput for write operations. By default, the tape controller's write cache is disabled for the device.</p> <p>This option applies only to tape systems that support a write cache.</p>
MNT\$M_VERIFY_LABEL	<p>Requires that any member to be added to the shadow set have a volume label of SCRATCH_DISK. This helps ensure that the wrong disk is not added to a shadow set. If you plan to use VERIFY_LABEL, you must first assign the disk to a label. You can do this either by initializing the disk to be added to the set with the label SCRATCH_DISK, or by specifying the label for the disk with the SET VOLUME/LABEL command.</p>
MNT\$M_WRITECHECK	<p>Write checks are to be performed after all write operations.</p>
MNT\$M_WRITETHRU	<p>Disables the deferred write feature for file headers. By default this feature is enabled, which improves the performance of the applications, such as PATHWORKS, that use it. The deferred write feature is not available on Files-11 ODS-1 volumes.</p>
MNT2\$M_CDROM	<p>Mounts a volume assuming the media to be ISO 9660 (or High Sierra) formatted.</p>
MNT2\$M_COMPACTION	<p>Enables data compaction for those magnetic tapes that support data compaction (TA90, TA91, and others).</p>
MNT2\$M_DISKQ	<p>Controls whether quotas are to be enforced on the specified disk volume.</p>
MNT2\$_DSI	<p>Enables XAR permissions Owner and Group for XARs containing Digital System Identifiers (DSI). For more information, see the <i>VSI OpenVMS Record Management Services Reference Manual</i>.</p>

Option	Description
MNT2\$_INCLUDE	Automatically reconstructs a former shadow set to the way it was before the shadow set was dissolved. Applicable only if you have the volume shadowing option. For more information, see <i>VSI OpenVMS Volume Shadowing Guide</i> .
MNT2\$_M_NOCOMPACTION	Forces the density to no compaction for those magnetic tapes that support data compaction (TA90, TA91, and others).
MNT2\$_OVR_LIMITED_SEARCH	For disk type devices that do not provide for bad-block revectoring, it is possible that the Files-11 homeblock has been placed numerous I/Os from the start of the volume. To decrease the failover time when accessing media which does not contain a valid Files-11 homeblock, a limited-search algorithm was implemented. This switch overrides the limited-search algorithm so that the entire volume will be searched for a valid Files-11 homeblock.
MNT2\$_M_OVR_NOFE	This bit mask is set to override those SCSI devices that do not support forced error functionality. By overriding those SCSI devices not supporting forced error capabilities, MNT2\$_M_OVR_NOFE enables those devices to be mounted. Otherwise, the shadowing code would report to \$MOUNT that the device does not support forced error, and the device would not be mounted.
MNT2\$_OVR_SECURITY	Enables you to continue mounting a volume if an error is returned because the volume has an invalid SECURITY.SYS file. You must have the VOLPRO privilege or own the volume to use this keyword.
MNT2\$_M_SUBSYSTEM	Enables the processing of protected subsystem identifiers on the volume. By default, subsystem identifiers are ignored on all but the system disk. Requires SECURITY privilege.
MNT2\$_M_XAR	Enables enforcement of the extended record attribute (XAR) access controls. For more information about XAR, see the <i>VSI OpenVMS System Manager's Manual</i> .

MNT\$_LIMIT

The MNT\$_LIMIT item code specifies the maximum amount of free space in the extent cache. The buffer must contain a longword value, which specifies the amount of free space in units of tenths of a percent of the disk's total free space. The MNT\$_LIMIT item code applies only to disks.

MNT\$_LOGNAM

The MNT\$_LOGNAM item code specifies a logical name for the volume; this logical name is equated to the device name specified by the first MNT\$_DEVNAM item code. The buffer must contain a character string from 1 to 64 characters, which is the logical name.

Unless you specify MNT\$_M_GROUP or MNT\$_M_SYSTEM, the logical name is entered in the process logical name table.

MNT\$_NODATA

Specifies whether the XFC is to be disabled on the disk. This value is the default, when you specify NOQUOTA, NOFILEID, NOEXTENT, or WRITETHROUGH qualifier with the MOUNT command.

MNT\$_OWNER

The MNT\$_OWNER item code specifies the UIC to be assigned ownership of the volume. The buffer must contain a longword octal value, which is the UIC. If the volume is Files-11 structured, the specified value overrides the ownership recorded on the volume. You need either VOLPRO privilege or ownership of the volume to assign a UIC to a Files-11 structured volume.

MNT\$_PROCESSOR

For magnetic tapes and Files-11 On-Disk Structure Level 1 disks, MNT\$_PROCESSOR specifies the name of the ancillary control process (ACP) that is to process the volume. The specified ACP overrides the default ACP associated with the device.

For Files-11 On-Disk Structure Level 2 disks, MNT\$_PROCESSOR controls block cache allocation.

To specify MNT\$_PROCESSOR, the caller must have OPER privilege.

The buffer must contain a character string specifying either the string UNIQUE, a device name, or a file specification. Following is a description of the action taken for each of these cases.

String	Description
UNIQUE	For magnetic tapes and Files-11 Structure Level 1 disks, UNIQUE specifies that \$MOUNT create a new process to execute a copy of the default ACP image associated with the device specified by the MNT\$_DEVNAM item code. For Files-11 Structure Level 2 disks, UNIQUE allocates a separate block cache.
ddcu	For magnetic tapes and Files-11 Structure Level 1 disks, <i>ddcu</i> specifies that \$MOUNT use the ACP process currently being used by the device <i>ddcu</i> . The device specified must be in the format <i>ddcu</i> , for example, DRA3. For Files-11 Structure Level 1 disks, <i>ddcu</i> specifies that \$MOUNT take the block allocation from the specified device.
filespec	Specifies that \$MOUNT create a new process to execute the ACP image with the file specification <i>filespec</i> . Wildcard characters are not allowed in the file specification. The file must be in the disk and directory specified by the logical name SYS\$SYSTEM. This operation requires CMKRNL privilege.

MNT\$_QUOTA

The MNT\$_QUOTA item code specifies the size of the quota record cache in units of quota records. The buffer must contain a longword value, which is this size. To specify MNT\$_QUOTA, you need OPER privilege. The value 0 disables caching. The MNT\$_QUOTA item code applies only to disks.

MNT\$_RECORDSIZ

The MNT\$_RECORDSIZ item code specifies the number of characters in each record and is used with MNT\$_BLOCKSIZE to specify the data formats for foreign volumes. The buffer must contain a longword value less than or equal to the block size. The MNT\$_RECORDSIZ item code applies only to tapes.

If you do not specify MNT\$_RECORDSIZ, the record size is assumed to be equal to the block size.

MNT\$_SHAMEM

The MNT\$_SHAMEM item code specifies the name of a physical device to be mounted into a shadow set. The MNT\$_SHAMEM descriptor is a 1- to 64-character string containing the device name. The string can be a physical device name or a logical name; if it is a logical name, it must translate to a physical device name. An item list must contain at least one item descriptor specifying a member; this item descriptor must appear after the MNT\$_SHANAM item descriptor.

Volume Shadowing for OpenVMS automatically performs a copy or a merge operation, if necessary, when it mounts the disk into the shadow set.

MNT\$_SHANAM

The MNT\$_SHANAM item code specifies the name of the virtual unit to be mounted. The buffer is a 1- to 64-character string containing the device name. The virtual unit name can be a logical name; if it is a logical name, it must translate to a virtual unit name.

Because every shadow set is represented by a virtual unit, you must include at least one MNT\$_SHANAM item descriptor in the item list that you pass to \$MOUNT to create and mount the shadow set. If you are mounting a volume set containing more than one shadow set, you must include one MNT\$_SHANAM item descriptor for each virtual unit included in the volume set.

The relative position of the item descriptors in the item list determines the membership of the shadow set. That is, it indicates which members should be bound to a specific virtual unit to form the shadow set. You must first specify the virtual unit by using the MNT\$_SHANAM item code. Then, you can specify any number of members that are to be represented by that virtual unit by using one of the following item codes: MNT\$_SHAMEM, MNT\$_SHAMEM_COPY, or MNT\$_SHAMEM_MGCOPY. If you specify one shadow set and want to specify a second, specify a second virtual unit item descriptor. The members you specify subsequently are bound to the shadow set represented by the virtual unit specified in the second virtual unit item descriptor.

MNT\$_UCS

The MNT\$_UCS item code specifies a descriptor containing a Universal Character Sequence (UCS) defined by ISO 2022 and used when mounting an ISO 9660 CD-ROM. For more information, see the *VSI OpenVMS System Manager's Manual*.

MNT\$_UNDEFINED_FAT

The MNT\$_UNDEFINED_FAT item code specifies the default file attributes to be used for the records on ISO 9660 media for which no record format has been specified.

The buffer contains a 32-bit structure that defines a file's record format, record attributes, and maximum record size.

The following diagram depicts the structure of the Undefined File Attributes buffer.

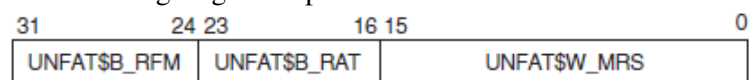

ZK-6644A-GE

The following table defines the buffer fields.

Buffer Field	Definition
UNFAT\$W_MRS	Maximum record size; specifies the maximum record size for all records in a file: 0 to 32767. Applies only to FIXED or STREAM formats.

Buffer Field	Definition
UNFAT\$B_RAT	Record attributes; specifies the attributes for all records in a file: NONE, CR, FTN, PRN, NOBKS. Applies only to non-STREAM record formats.
UNFAT\$B_RFM	Record format; specifies the format for all records in a file: FIXED, VARIABLE, STREAM, STREAM_LF, STREAM_CR, LSB_VARIABLE, or MST_VARIABLE.

MNT\$_VOLNAM

The MNT\$_VOLNAM item code specifies the name of the volume to be mounted on the device. The number of characters allowed in a volume name depends on the type of device, as follows:

Device Type	Number of Characters in Label
Magnetic tape	0–6
Files-11 disk	1–12
ISO 9660 disk	1–32

The operating system requires disk volume labels to be unique in the first 12 characters within a given domain.

The MNT\$_VOLNAM item code can appear more than once in an item list; it appears more than once when a volume set is being mounted because, in this case, one volume name is given to each volume in the volume set.

When a disk volume set is being mounted, you must specify MNT\$_DEVNAM and MNT\$_VOLNAM once for each volume of the volume set. The \$MOUNT service mounts the volume specified by the first MNT\$_VOLNAM item code on the device specified by the first MNT\$_DEVNAM item code in the item list; it mounts the volume specified by the second MNT\$_VOLNAM code on the device specified by the second MNT\$_DEVNAM code, and so on for all specified volumes and devices. Thus, there must be an equal number of these two item codes in the item list.

When a tape volume set is being mounted, the number of MNT\$_DEVNAM item codes specified need not be equal to the number of MNT\$_VOLNAM item codes specified, because more than one volume can be mounted on the same device.

MNT\$_VOLSET

The MNT\$_VOLSET item code specifies the name of a volume set. The buffer must contain a character string from 1 to 12 alphanumeric characters, which is the volume set name.

An ISO 9660 volume set name can be from 1 to 128 characters in length.

Volume set names must be unique in the first 12 characters. In addition, if the first 12 characters of the volume set name are the same as the first 12 characters of any volume label, a lock manager deadlock will occur. To avoid this problem, you must override either the volume label (by using the MNT\$_VOLNAM item code) or the volume set name (by using the MNT\$_VOLSET item code).

When you specify MNT\$_VOLSET, volumes specified by the MNT\$_VOLNAM item code are bound into a new volume set or added to an existing volume set, depending on whether the name specified by MNT\$_VOLSET is a new or already existing name.

When you specify MNT\$_VOLSET to add volumes to an existing volume set, the root volume (RVN1) must either (1) already be mounted or (2) be specified first (by the MNT\$_DEVNAM and MNT\$_VOLNAM item codes) in the item list.

When you specify MNT\$_VOLSET to create a new volume set, the first volume specified (by the MNT\$_DEVNAM and MNT\$_VOLNAM item codes) in the item list becomes the root volume.

MNT\$_VPROT

The MNT\$_VPROT item code specifies the protection to be assigned to the volume. The buffer must contain a longword protection mask, which specifies the four types of access allowed to the four categories of user.

The protection mask consists of four 4-bit fields. Each field grants or denies read, write, logical, and physical access to a category of users. Cleared bits grant access; set bits deny access. The following diagram depicts the structure of the protection mask.

World				Group				Owner				System			
P	L	W	R	P	L	W	R	P	L	W	R	P	L	W	R
15	14	13	12	11	10	9	8	7	6	5	4	3	2	1	0

ZK-1715-GE

If you do not specify MNT\$_VPROT or specify it as the value 0, the volume receives the protection that it was assigned when it was initialized. To specify MNT\$_VPROT for a Files-11 structured volume, the caller must either own the volume or have VOLPRO privilege.

MNT\$_WINDOW

The MNT\$_WINDOW item code specifies the number of mapping pointers to be allocated for file windows. The buffer must contain a longword value in the range 7 to 80. This value overrides the default value that was applied when the volume was initialized. The MNT\$_WINDOW item code applies only to disks.

When a file is opened, the file system uses the mapping pointers to access the data in the file. To specify MNT\$_WINDOW, you need OPER privilege.

Description

The Mount Volume service mounts a tape, disk volume, or volume set and specifies options for the mount operation.

When a subprocess mounts a private volume without explicitly allocating the device, the master process of the job becomes the owner of this device. This provision is necessary because the subprocess can be deleted and the volume should remain privately mounted for this job.

When a subprocess explicitly allocates a device and then mounts a private volume on this device, this subprocess retains the device ownership. In this case, only subprocesses of the device owner, and processes with SHARE privilege, have access to the device.

The \$MOUNT service uses the following system resources to mount volumes with group or systemwide access allowed:

- Nonpaged pool
- Paged pool

When \$MOUNT mounts a disk volume, the logical name DISK\$volume-label is always created. If you specify a logical name in the mount request that is different from DISK\$volume-label, there will be two logical names associated with the device.

If the logical name of a volume is in a process-private table, then the name is not deleted when the volume is dismounted.

Required Access or Privileges

To mount a volume on a device, you must have read or control access to that device.

To mount a particular volume, the caller must either own or have privilege to access the specified volume or volumes. The privileges required depend on the operation and are listed with the item codes that specify the operation.

The calling process must have TMPMBX or PRMMBX privilege to perform an operator-assisted mount.

SECURITY privilege is required to enable protected subsystems.

Required Quota

None

Related Services

\$ALLOC, \$ASSIGN, \$BRKTHRU, \$BRKTHRUW, \$CANCEL, \$CREMBX, \$DALLOC, \$DASSGN, \$DELMBX, \$DEVICE_SCAN, \$DISMOU, \$GETDVI, \$GETDVIW, \$GETMSG, \$GETQUI, \$GETQUIW, \$INIT_VOL, \$PUTMSG, \$QIO, \$QIOW, \$SNDERR, \$SNDJBC, \$SNDJBCW, \$SNDOPR

Condition Values Returned

SS\$_NORMAL

The service completed successfully.

SS\$_ACCVIO

The item list or an address specified in the item list cannot be accessed.

SS\$_BADPARAM

A buffer length of 0 was specified with a nonzero item code; an illegal item code was specified; or no device was specified.

SS\$_NOGRPNAM

The caller does not have GRPNAM privilege.

SS\$_NOHOMEBLK

Files-11 home block not found on volume.

SS\$_NOOPER

The caller does not have the required OPER privilege.

SS\$_NOPRIV

The caller does not have sufficient privilege to access a specified volume.

SS\$_NOSUCHDEV

The specified device does not exist on the host system.

SS\$_NOSYSNAM

The caller does not have SYSNAM privilege.

The \$MOUNT service can also return a condition value that is specific to the Mount utility. The symbolic definition macro \$MOUNDEF defines these condition values.

\$MTACCESS

Magnetic Tape Accessibility — Allows installations to provide their own routine to interpret and output the accessibility field in the VOL1 and HDR1 labels of an ANSI labeled magnetic tape.

Format

```
SY$_MTACCESS  
    lblnam , [uic] , [std_version] , [access_char] , [access_spec] , type
```

C Prototype

```
int sys$mtaccess  
    (unsigned int *lblnam, unsigned int uic, unsigned int std_version,  
     unsigned int access_char, unsigned int access_spec,  
     unsigned int type);
```

Arguments

lblnam

OpenVMS usage: address
type: longword (unsigned)
access: read only
mechanism: by reference

ANSI label to be processed. The *lblnam* argument is the address of a longword containing the label. On input, the label passed is either the VOL1 or HDR1 label read from the magnetic tape; on output of labels, the value of this field is 0. The type of label passed is determined by *type*.

uic

OpenVMS usage: uic
type: longword (unsigned)
access: read only
mechanism: by value

UIC of the user performing the operation. The *uic* argument is a longword containing the UIC.

std_version

OpenVMS usage: longword_unsigned
type: longword (unsigned)
access: read only
mechanism: by value

Decimal equivalent of the ANSI standard version read from the VOL1 label. The *std_version* argument is a longword containing the standard version number.

access_char

OpenVMS usage: longword_unsigned
type: longword (unsigned)
access: read only
mechanism: by value

Accessibility character specified by the user. The *access_char* argument is a byte containing the accessibility character used for the output of labels.

access_spec

OpenVMS usage: longword_unsigned
type: longword (unsigned)
access: read only
mechanism: by value

Value specifying whether the accessibility character passed in *access_char* was specified by the user. The *access_spec* argument is a byte containing one of the following values.

Value	Meaning
MTA\$K_CHARVALID	Yes
MTA\$K_NOCHAR	No

This argument is used only for the output of labels.

type

OpenVMS usage: longword_unsigned
type: longword (unsigned)
access: read only
mechanism: by value

Type of accessibility field to process. The *type* argument is a byte containing one of the following values.

Value	Meaning
MTA\$K_INVOL1	Input a VOL1 label
MTA\$K_INHDR1	Input a HDR1 label

Value	Meaning
MTASK_OUTVOL1	Output a VOL1 label
MTASK_OUTHDR1	Output a HDR1 label

Description

The Magnetic Tape Accessibility service allows installations to provide their own routine to interpret and output the accessibility field in the VOL1 and HDR1 labels of ANSI labeled magnetic tapes. The installation can override the default routine by providing an MTACCESS.EXE executive loaded image.

The default installation routine first checks the ANSI standard version of the label. For magnetic tapes with a version number of 3 or less, the routine outputs either a blank or the character you specified. On input of these magnetic tapes, the routine checks for a blank and returns the value SS\$_FILACCERR if the field is not blank.

For magnetic tapes with a version number greater than 3, the routine outputs either the character specified by the *access_char* argument or an ASCII 1 if no character was specified. On input of these magnetic tapes, the routine checks for a blank. If the field is blank, R0 is set to 0. In that case, you are given full access and protection is not checked. If the field contains an ASCII 1, and the VOL1 Implementation Identifier field contains the system code, R0 is set to SS\$_NORMAL. In that case, the protection is checked.

If the field is not blank and does not contain an ASCII 1, R0 is set to SS\$_FILACCERR, which forces you to override accessibility checking and allows the magnetic tape file system to check protection.

The following table summarizes the results of label input check.

Contents of R0	Result
SS\$_NORMAL	Check the protection on the magnetic tape.
0	Give the user full access. Protection is not checked.
SS\$_FILACCERR	Check for explicit override, then check protection.

Note that the default accessibility routine does not output SS\$_NOVOLACC or SS\$_NOFILACC. These statuses are included for the installation's use, and the magnetic tape file system handles these cases.

The magnetic tape file system calls \$MTACCESS to process the accessibility field in the VOL1 and HDR1 labels. After a call to the system service, the magnetic tape file system checks that the installation did not move the magnetic tape. If the magnetic tape was moved, the magnetic tape file system completes the current operation with an SS\$_TAPEPOSLOST error. Finally, it processes the remainder of the label according to the status returned by \$MTACCESS.

Required Access or Privileges

Because accessibility is an installation-provided routine, the operating system cannot determine which users have the authority to override the processing of this field. However, the magnetic tape file system allows only operator class users to deal with blank magnetic tapes so that a user must have both OPER and VOLPRO privileges to initialize or mount blank magnetic tapes.

Required Quota

None

Related Services

\$ADD HOLDER, \$ADD_IDENT, \$ASCTOID, \$CHECK_ACCESS, \$CHKPRO, \$CREATE_RDB, \$ERAPAT, \$FIND_HELD, \$FIND HOLDER, \$FINISH_RDB, \$FORMAT_ACL, \$FORMAT_AUDIT, \$GET_SECURITY, \$GRANTID, \$HASH_PASSWORD, \$IDTOASC, \$MOD HOLDER, \$MOD_IDENT, \$PARSE_ACL, \$REM HOLDER, \$REM_IDENT, \$REVOKID, \$SET_SECURITY

Condition Values Returned

SS\$_NORMAL

The service completed successfully.

SS\$_FILACCERR

The accessibility characteristic in the HDR1 label is not blank and you cannot access the file without overriding the field.

SS\$_NOFILACC

The user has no access to the file.

SS\$_NOVOLACC

The user has no access to the volume.

\$NUMTIM

Convert Binary Time to Numeric Time — Converts an absolute or delta time from 64-bit system time format to binary integer date and time values. On Alpha and Integrity server systems, this service accepts 64-bit addresses.

Format

```
SYS$NUMTIM timbuf , [timadr]
```

C Prototype

```
int sys$numtim  
    (unsigned short int timbuf [7], struct _generic_64 *timadr);
```

Arguments

timbuf

OpenVMS usage: vector_word_unsigned
type: word (unsigned)
access: write only

mechanism: by 32- or 64-bit reference (Alpha and Integrity servers)

Buffer into which \$NUMTIM writes the converted date and time. The *timbuf* argument is the 32- or 64-bit address (on Alpha and Integrity server systems) of a 7-word structure.

The following diagram depicts the fields in this structure:

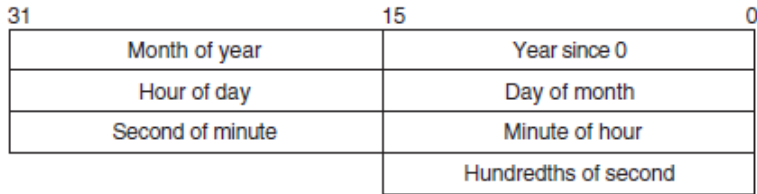

ZK-1716-GE

If the *timadr* argument specifies a delta time, \$NUMTIM returns the value 0 in the year since 0 and month of year fields. It returns in the day of month field the number of days specified by the delta time.

timadr

OpenVMS usage: date_time

type: quadword

access: read only

mechanism: by 32- or 64-bit reference (Alpha and Integrity servers)

The 64-bit time value to be converted. The *timadr* argument is the 32- or 64-bit address (on Alpha and Integrity server systems) of a quadword containing this time. A positive-time value represents an absolute time, while a negative time value indicates a delta time.

If you do not specify *timadr*, \$NUMTIM returns the current system time.

If *timadr* specifies the value 0, \$NUMTIM returns the base date (November 17, 1858).

Condition Values Returned

SS\$_NORMAL

The service completed successfully.

SS\$_ACCVIO

The 64-bit time value cannot be read by the caller, or the buffer cannot be written by the caller.

SS\$_IVTIME

The specified delta time is equal to or greater than 10,000 days.

\$NUMUTC

Convert UTC Time to Numeric Components — Converts an absolute 128-bit binary time into its numeric components. The numeric components are returned in local time. On Alpha and Integrity server systems, this service accepts 64-bit addresses.

Format

```
SYS$NUMUTC timbuf , [utcadr]
```

C Prototype

```
int sys$numutc (unsigned short int timbuf [13], unsigned int *utcadr [4]);
```

Arguments

timbuf

OpenVMS usage: vector_word_unsigned
 type: word
 access: write only
 mechanism: by 32- or 64-bit reference (Alpha and Integrity servers)

Buffer into which \$NUMUTC writes the converted date and time. The *timbuf* argument is the 32- or 64-bit address (on Alpha and Integrity server systems) of a 13-word structure containing time, inaccuracy of time, and time differential factor. The time differential factor encoded in the 128-bit buffer is used to convert the UTC to its numerical components. Negative values in the inaccuracy field indicate an infinite inaccuracy.

The following diagram depicts the fields in this structure:

31	15	0
Month of year	Year since 0	
Hour of day	Day of month	
Second of minute	Minute of hour	
Inacc days	Hundredths of second	
Inacc minutes	Inacc hours	
Inacc hundredths of second	Inacc seconds	
	TDF in minutes	

ZK-4631A-GE

utcadr

OpenVMS usage: coordinated universal time
 type: utc_date_time
 access: read only
 mechanism: by 32- or 64-bit reference (Alpha and Integrity servers)

The 128-bit UTC time value to be converted.

The *utcadr* argument is optional; if it is not used, \$NUMUTC will use the current time.

Condition Values Returned

SS\$_NORMAL

The service completed successfully.

SS\$_INVTIME

The 128-bit UTC time is not valid.

\$NXTVOL

Next Volume — The Next Volume service allows you to process the next tape volume in a multiple volume set. This service applies only to files on magnetic tape volumes.

For additional information about this service, see the *VSI OpenVMS Record Management Services Reference Manual*.

\$OPEN

Opens File — The Open service makes an existing file available for processing by your program. The Open service specifies the type of record access to be used and determines whether the file can be shared. The Open service also performs an implicit Display service.

For additional information about this service, see the *VSI OpenVMS Record Management Services Reference Manual*.

\$PARSE

Analyze File Specification String — The Parse service analyzes the file specification string and fills in various NAM block fields.

For additional information about this service, see the *VSI OpenVMS Record Management Services Reference Manual*.

\$PARSE_ACL

Parse Access Control List Entry — Parses the specified text string and converts it to the binary representation for an access control entry (ACE).

Format

```
SYS$PARSE_ACL aclstr ,aclent ,[errpos] ,[accnam] ,[nullarg]
```

C Prototype

```
int sys$parse_acl
    (void *aclstr, void *aclent, unsigned short int *errpos, void *accnam,
     int (*routin)(void));
```

Arguments

aclstr

OpenVMS usage: char_string
type: character-coded text string
access: read only
mechanism: by descriptor—fixed-length string descriptor

Formatted ACE that is parsed when \$PARSE_ACL completes execution. The *aclstr* argument is the address of a string descriptor pointing to the text string to be parsed.

aclet

OpenVMS usage: char_string
type: character-coded text string
access: write only
mechanism: by descriptor—fixed-length string descriptor

Description of the ACE that is parsed when \$PARSE_ACL completes execution. The *aclet* argument is the address of a descriptor pointing to the buffer in which the ACE is written. The first byte of the buffer contains the length of the ACE; the second byte contains a value that identifies the type of ACE, which in turn defines the format of the ACE. For information about the ACE types and their associated formats, see \$FORMAT_ACL system service documentation.

errpos

OpenVMS usage: word_unsigned
type: word (unsigned)
access: write only
mechanism: by reference

Number of characters from *aclstr* processed by \$PARSE_ACL. The *errpos* argument is the address of a word that receives the number of characters actually processed by the service. If the service fails, this count points to the failing point in the string.

accnam

OpenVMS usage: access_bit_names
type: longword (unsigned)
access: read only
mechanism: by reference

Names of the bits in the access mask when \$PARSE_ACL is executing. The *accnam* argument is the address of an array of 32 quadword descriptors that define the names of the bits in the access mask. Each element points to the name of a bit. The first element names bit 0, the second element names bit 1, and so on.

You can call LIB\$GET_ACCNAM to retrieve the access name table for the class of object whose ACL is to be formatted. If you omit *accnam*, the following names are used.

Bit	Name
Bit 0	READ

Bit	Name
Bit 1	WRITE
Bit 2	EXECUTE
Bit 3	DELETE
Bit 4	CONTROL
Bit 5	BIT_5
Bit 6	BIT_6
.	
.	
.	
Bit 31	BIT_31

nullarg

OpenVMS usage: null_arg
type: longword (unsigned)
access: read only
mechanism: by value

Placeholder argument reserved to OpenVMS.

Description

The Parse Access Control List Entry service parses the specified text string and converts it to the binary representation for an access control entry (ACE).

Required Access or Privileges

None

Required Quota

None

Related Services

\$ADD HOLDER, \$ADD_IDENT, \$ASCTOID, \$CHECK_ACCESS, \$CHKPRO, \$CREATE_RDB,
\$ERAPAT, \$FIND_HELD, \$FIND HOLDER, \$FINISH_RDB, \$FORMAT_ACL,
\$FORMAT_AUDIT, \$GET_SECURITY, \$GRANTID, \$HASH_PASSWORD, \$IDTOASC,
\$MOD HOLDER, \$MOD_IDENT, \$MTACCESS, \$REM HOLDER, \$REM_IDENT, \$REVOKID,
\$SET_SECURITY

Condition Values Returned

SS\$_NORMAL

The service completed successfully.

SS\$_ACCVIO

The string or its descriptor cannot be read by the caller; the buffer descriptor cannot be read by the caller; the buffer cannot be written by the caller; or the buffer is too small to hold the ACL entry.

SS\$_IVACL

The format of the access control list entry is not valid.

SS\$_NOSUCHID

The specified identifier does not exist in the rights database.

\$PERM_DIS_ALIGN_FAULT_REPORT (Alpha and Integrity servers)

Disable Alignment Fault Reporting — On Alpha and Integrity server systems, disables user process alignment fault reporting.

Format

`SYSPERM_DIS_ALIGN_FAULT_REPORT`

C Prototype

```
int sys$perm_dis_align_fault_report (void);
```

Arguments

None.

Description

The Disable Alignment Fault Reporting service disables user process alignment fault reporting.

See the description of the \$PERM_REPORT_ALIGN_FAULT service for an example of a program that can be used to enable and disable user process alignment fault reporting.

Required Access or Privileges

None

Required Quota

None

Related Services

`$GET_ALIGN_FAULT_DATA`, `$GET_SYS_ALIGN_FAULT_DATA`,
`$INIT_SYS_ALIGN_FAULT_REPORT`, `$PERM_REPORT_ALIGN_FAULT`,

`$START_ALIGN_FAULT_REPORT`, `$STOP_ALIGN_FAULT_REPORT`,
`$STOP_SYS_ALIGN_FAULT_REPORT`

Condition Values Returned

`SS$_NORMAL`

The service completed successfully.

`$PERM_REPORT_ALIGN_FAULT` (Alpha and Integrity servers)

Report Alignment Fault — On Alpha and Integrity server systems, initializes user process alignment fault reporting.

Format

`SYS$PERM_REPORT_ALIGN_FAULT`

C Prototype

```
int sys$perm_report_align_fault (void);
```

Arguments

None.

Description

The Report Alignment Fault service allows the user to permanently enable user process alignment fault reporting for all subsequent images.

This service reports alignment faults only in exception mode. For more information about reporting modes, see the `$START_ALIGN_FAULT_REPORT` service.

Image alignment fault reporting takes precedence over process alignment fault reporting. That is, if both image and process alignment fault reporting are enabled, faults are reported to the image first.

Required Access or Privileges

None

Required Quota

None

Related Services

`$GET_ALIGN_FAULT_DATA`, `$GET_SYS_ALIGN_FAULT_DATA`,
`$INIT_SYS_ALIGN_FAULT_REPORT`, `$PERM_DIS_ALIGN_FAULT_REPORT`,

\$START_ALIGN_FAULT_REPORT, \$STOP_ALIGN_FAULT_REPORT,
\$STOP_SYS_ALIGN_FAULT_REPORT

Condition Values Returned

SS\$_NORMAL

The service completed successfully.

Example

```

/*****
/*
/* SET_ALIGN_REPORT.C
/*
/* This program can be used to permanently turn on and off
/* alignment fault reporting for a process. After creating the
/* executable, do:
/*
/*     $ align := $dir:set_align_report.exe
/*     $ align on
/*     $ run program      ! will generate align faults on screen
/*     $ align off
/*     $ run program      ! will not generate align faults
/*
*****/

#include <stdio>
#include <ctype>
#include <ssdef>

/*          alignment fault reporting system services          */
extern      sys$perm_report_align_fault(),
            sys$perm_dis_align_fault_report();

main(argc, argv)
    int      argc;
    char     *argv[];
{
    int      status;

    /* check arguments */
    if (argc < 2) {
        printf ("Insufficient arguments\n");
        return (40);
    }

    /* check if the argument is on or off */
    if ((strcmp ("ON", argv[1]) == 0) || (strcmp ("on", argv[1]) == 0))
        /* on, turn alignment fault reporting on for this process */
        status = sys$perm_report_align_fault ();

    else if ((strcmp ("OFF", argv[1]) == 0) || (strcmp ("off", argv[1]) ==
0))
        /* off, turn alignment fault reporting off for this process */
        status = sys$perm_dis_align_fault_report ();

```

```
else
    return (SS$_BADPARAM);

/* return status */
return (status);
}
```

This example shows a program that can be used to enable and disable alignment fault reporting for a process.

\$PERSONA_ASSUME (Alpha and Integrity servers)

Assume Persona — On Alpha and Integrity server systems, allows an OpenVMS thread to assume the identity of another persona.

Format

```
SYS$PERSONA_ASSUME persona , [flags], [previous], [acmode]
```

C Prototype

```
int sys$persona_assume
(unsigned int *persona, unsigned int flags, unsigned int *previous,
 unsigned int acmode);
```

Arguments

persona

OpenVMS usage: persona
type: longword (unsigned)
access: read only
mechanism: by reference

Address of a longword in which the persona identification handle is expected.

If the value passed is ISS\$C_ID_NATURAL, then the state of the calling thread is returned to the natural persona.

flags

OpenVMS usage: mask_longword
type: longword (unsigned)
access: read only
mechanism: by value

Ignored.

previous

OpenVMS usage: persona
type: longword (unsigned)
access: write only
mechanism: by reference

Address of a longword into which the persona identification handle of the currently active persona being replaced is written.

acmode

OpenVMS usage: access_mode
type: longword (unsigned)
access: read only
mechanism: by value

Access mode to be considered when assuming a persona. The *acmode* argument is a longword containing the access mode.

The most privileged access mode used is the access mode of the caller. Only equal or more privileged access modes can use this persona.

Description

This service establishes the specified persona as the active security profile and returns the persona identification handle of the persona that was active at the point in which the call to this service was made.

On image exit, the natural persona is assumed and all nonpermanent personae are deleted.

The arguments are validated against the caller's mode, so an invalid argument can cause an access violation to be signaled.

Required Access or Privileges

None

Required Quota

None

Related Services

\$PERSONA_CLONE, \$PERSONA_CREATE, \$PERSONA_CREATE_EXTENSION,
\$PERSONA_DELETE_EXTENSION, \$PERSONA_DELEGATE, \$PERSONA_DELETE,
\$PERSONA_EXTENSION_LOOKUP, \$PERSONA_FIND, \$PERSONA_MODIFY,
\$PERSONA_QUERY, \$PERSONA_RESERVE

Condition Values Returned

SS\$_NORMAL

The service completed successfully; the desired access is granted.

SS\$_ACCVIO

Access violation.

SS\$_INSFARG

Certain required arguments were not specified.

SS\$_IVMODE

The caller cannot create a persona that is more privileged than the caller.

SS\$_NOPRIV

The operation requires IMPERSONATE privilege.

SS\$_PERSONANONGRATA

Invalid persona argument.

\$PERSONA_CLONE (Alpha and Integrity servers)

Clone Persona — On Alpha and Integrity server systems, creates a copy of an existing persona within the context of the current process. The service returns the assigned persona identification for the new persona in the *persona* argument. This persona can be assumed using the \$PERSONA_ASSUME service.

Format

```
SYS$PERSONA_CLONE persona , [input]
```

C Prototype

```
int sys$persona_clone (unsigned int *persona, unsigned int *input);
```

Arguments

persona

OpenVMS usage: persona
type: longword (unsigned)
access: write only
mechanism: by reference

Address of a longword into which the persona identification handle is written.

input

OpenVMS usage: persona
type: longword (unsigned)

access: write only
mechanism: by reference

Address of a longword containing the persona identification of the persona to be cloned. If this argument is 0, null, or absent, the currently active persona is cloned.

Description

The Clone Persona service creates a copy of an existing persona within the context of the current process. The service returns the assigned persona identification for the new persona in the *persona* argument. This persona can be assumed using the \$PERSONA_ASSUME service.

On image exit, the natural persona is assumed and all nonpermanent personae are deleted.

Required Access or Privileges

None

Required Quota

BYTLM

Related Services

\$PERSONA_ASSUME, \$PERSONA_CREATE, \$PERSONA_CREATE_EXTENSION,
\$PERSONA_DELETE_EXTENSION, \$PERSONA_DELEGATE, \$PERSONA_DELETE,
\$PERSONA_EXTENSION_LOOKUP, \$PERSONA_FIND, \$PERSONA_MODIFY,
\$PERSONA_QUERY, \$PERSONA_RESERVE

Condition Values Returned

SS\$_NORMAL

The service completed successfully.

SS\$_ACCVIO

Access violation.

SS\$_EXQUOTA

The caller lacks sufficient quota to allocate a new persona.

SS\$_INSFMEM

Insufficient memory.

SS\$_IVMODE

The caller cannot create a persona that is more privileged than the caller.

SS\$_PERSONANONGRATA

The persona ID supplied was invalid.

\$PERSONA_CREATE (Alpha and Integrity servers)

Create Persona — On Alpha and Integrity server systems, creates a persona that can be assumed using the \$PERSONA_ASSUME service.

Format

```
SYS$PERSONA_CREATE persona , [usrnam] , [flags], [usrpro], [itmlst]
```

C Prototype

```
int sys$persona_create
(unsigned int *persona, void *usrnam, unsigned int flags,
 unsigned int *usrpro, unsigned int *itmlst);
```

Arguments

persona

OpenVMS usage: persona
type: longword (unsigned)
access: write only
mechanism: by reference

Address of a longword into which the persona identification handle is written.

usrnam

OpenVMS usage: char_string
type: character-coded text string
access: read only
mechanism: by descriptor - fixed-length descriptor

Name of the user to be impersonated. The *usrnam* argument is the address of a descriptor pointing to a character string containing the user name. The string can contain a maximum of 32 alphanumeric characters.

flags

OpenVMS usage: mask_longword
type: longword (unsigned)
access: read only
mechanism: by value

The \$ISSDEF macro defines these codes:

- ISS\$V_CREATE_AUTHPRIV - This bit is used to create a persona with the privilege fields set to the authorized privileges of the specified user.

- **ISS\$V_CREATE_DEFPRIV** - This bit is used for backward compatibility with the previous implementation of `personae`. This bit is accepted but not processed, as it describes the default behavior of the service.
- **ISS\$V_NOACCESS** - Tells `$PERSONA_CREATE` not to access the `SYSUAF` file. Only valid in `exec` or `kernel` mode.

usrpro

OpenVMS usage: `char_string`
type: `opaque byte stream`
access: `read only`
mechanism: `by descriptor`

Buffer containing an encoded security profile. The `usrpro` argument is the address of a descriptor pointing to a buffer that contains encoded security profile data. This profile can be created by calling the `SYS$CREATE_USER_PROFILE` system service.

itmlst

OpenVMS usage: `item_list_3`
type: `longword`
access: `read only`
mechanism: `by reference`

Attributes describing modifications to the security profile. The `itmlst` argument is the address of an `item_list` defining changes to be made to the specified user profile.

Item Codes

This section lists the `ISS$` item codes and definitions.

ISS\$_WORKPRIV

`$PERSONA_CREATE` sets the working privileges for the new persona as a quadword value.

ISS\$_MODE

`$PERSONA_CREATE` sets the access mode of the new persona as a longword value. The mode cannot be more privileged than that of the caller.

ISS\$_FLAGS

`$PERSONA_CREATE` sets the flags field of the new persona as a longword bit mask. The following bits are currently defined for this field:

- **ISS\$V_PERMANENT** - Mark this persona as permanent. It will survive image activations/deactivations.
- **ISS\$V_SECAUDIT** - Always audit this persona's operations.
- **ISS\$V_DEBIT** - Debit and credit the process `BYTLM/BYTCNT` for this persona. (This flag is always set for user mode persona.)

ISS\$_RIGHTS_INDEX

The index indicates into which rights chain the rights are placed. Values for the index are: ISS\$_M_ENABLED_PERSONA, ISS\$_M_ENABLED_SYSTEM, ISS\$_M_ENABLED_INSTALLED, ISS\$_M_ENABLED_SUBSYSTEM, and ISS\$_M_ENABLED_TEMPORARY. All subsequent rights item packets use the index until a new ISS\$_RIGHTS_INDEX item changes the index. If a rights index is not specified, the rights item packets will use the PERSONA chain as the default. Rights item packets include: ISS\$_AUTHRIGHTS, ISS\$_RIGHTS, ISS\$_ADD_AUTHRIGHTS, and ISS\$_ADD_RIGHTS.

ISS\$_AUTHRIGHTS (Reserved to OpenVMS)

\$PERSONA_CREATE sets the user authorized rights of the new persona as a list of quadword values. Any existing authorized rights will be overwritten. By default, the rights will be placed in the PERSONA rights chain. See ISS\$_RIGHTS_INDEX for more information on specifying different indexes.

ISS\$_RIGHTS

\$PERSONA_CREATE sets the user rights of the new persona as a list of quadword (paired longword) values. Any existing authorized rights will be overwritten. By default, the rights will be placed in the PERSONA rights chain. See ISS\$_RIGHTS_INDEX for more information on specifying different indexes. The format of the list is the same as ISS\$_AUTHRIGHTS.

The format of the list is as follows:

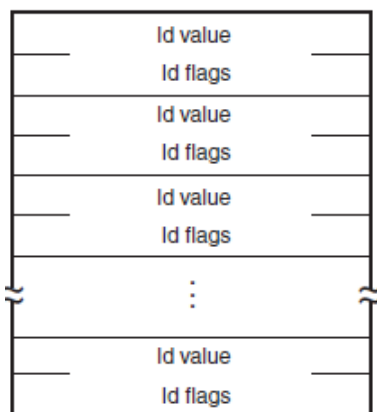

VM-0468A-AI

ISS\$_USERNAME

\$PERSONA_CREATE sets the user name of the new persona as a 32-byte character string.

ISS\$_ACCOUNT

\$PERSONA_CREATE sets the account of the new persona as a 32-byte character string.

ISS\$_NOAUDIT

\$PERSONA_CREATE sets the No Audit field of the new persona as a longword value.

ISS\$_UIC

\$PERSONA_CREATE sets the UIC of the new persona as a longword value.

ISS\$_AUTHPRIV

`$PERSONA_CREATE` sets the authorized privileges for the new persona as a quadword value.

ISS\$_PERMPRIV

`$PERSONA_CREATE` sets the permanent privileges for the new persona as a quadword value.

ISS\$_IMAGE_WORKPRIV

`$PERSONA_CREATE` sets the image working privileges for the new persona as a quadword value.

ISS\$_ENABLED

`$PERSONA_CREATE` sets the Rights Enable field of the new persona as a longword bit mask. These bits correspond to the indices of the different rights chains. By setting the bit in the `ENABLED` field, the corresponding rightslist chain will be enabled, and its rights will be included in all rights checks. Valid bits are: `ISS$V_ENABLED_PERSONA`, `ISS$V_ENABLED_SUBSYSTEM`, `ISS$V_ENABLED_IMAGE`, `ISS$V_ENABLED_SYSTEM`, and `ISS$V_ENABLED_TEMPORARY`.

ISS\$_ADD_AUTHRIGHTS

`$PERSONA_CREATE` adds the rights to the current list of authorized rights. `$PERSONA_CREATE` expects the same format as that outlined in `ISS$_AUTHRIGHTS`. By default, the rights will be placed in the `PERSONA` rights chain. See `ISS$_RIGHTS_INDEX` for more information on specifying different indexes.

ISS\$_ADD_RIGHTS

`$PERSONA_CREATE` adds the rights to the current list of rights. `$PERSONA_CREATE` expects the same format as that outlined in `ISS$_AUTHRIGHTS`. By default, the rights will be placed in the `PERSONA` rights chain. See `ISS$_RIGHTS_INDEX` for more information on specifying different indexes.

Description

When you call this service, you can specify either the `usrnam` or `usrpro` argument, but not both. The required information specifying the OpenVMS user is read from either the User Authorization File (UAF) and rights database or the `usrpro` buffer and is stored in system memory. Any modifications specified in the `itmlst` are then applied to complete the new persona. A persona identification handle that refers to the created persona is returned in the `persona` argument. This service creates a default VMS extension for the persona.

It is possible to call `$PERSONA_CREATE` in any mode. To call `$PERSONA_CREATE` in kernel mode, the calling sequence is different. Only the `usrpro` argument is valid (`usrnam` cannot be used because kernel mode access to the `SYSUAF` file is not allowed), and it is necessary to set the `PSB$M_NOACCESS` value in the `flags`.

No changes are made to the caller's thread as a result of calling `$PERSONA_CREATE`.

The arguments are validated against the caller's mode, so an invalid argument can cause an access violation to be signaled.

Required Access or Privileges

All calls to `$PERSONA_CREATE` require `IMPERSONATE` privilege and read access to the system authorization database.

Required Quota

BYTLM

Related Services

\$PERSONA_ASSUME, \$PERSONA_CLONE, \$PERSONA_CREATE_EXTENSION,
\$PERSONA_DELETE_EXTENSION, \$PERSONA_DELEGATE, \$PERSONA_DELETE,
\$PERSONA_EXTENSION_LOOKUP, \$PERSONA_FIND, \$PERSONA_MODIFY,
\$PERSONA_QUERY, \$PERSONA_RESERVE

Condition Values Returned

SS\$_NORMAL

The service completed successfully

SS\$_ACCVIO

The *persona* argument cannot be written by the caller.

SS\$_NOPRIV

The operation requires IMPERSONATE privilege.

SS\$_INSFMEM

Insufficient memory.

SS\$_USERDISABLED

User name disabled.

SS\$_IVMODE

The caller cannot create a persona that is more privileged than the caller.

SS\$_INSFARG

Certain required arguments were not specified.

SS\$_BADPARAM

The value of at least one of the arguments is incorrect.

SS\$_BADCHECKSUM

The buffer specified by *usrpro* is not valid.

SS\$_BADBUFLEN

The buffer length for data within the *usrpro* or *itmlst* was invalid.

SS\$_BADITMCO

At least one argument in the item code is invalid.

SS\$_INVARG

An incorrect combination of arguments was specified.

SS\$_INVSECDOMAIN

The buffer specified by **usrpro** contains data that originated outside the local security domain.

Any condition value returned by the \$LKWSET, \$GETUAI, or \$FIND_HELD service can also be returned.

\$PERSONA_CREATE_EXTENSION (Alpha and Integrity servers)

Create Persona Extension — On Alpha and Integrity server systems, creates an extension on the current persona. A persona extension is a mechanism to attach support for additional security credentials.

Format

```
SYS$PERSONA_CREATE_EXTENSION
    persona ,extensionID ,buffer ,length ,flags
```

C Prototype

```
int sys$persona_create_extension
    (unsigned int *persona, unsigned int *extensionID, void *buffer,
     unsigned int *length, unsigned int *flags);
```

Arguments

persona

OpenVMS usage: persona
type: longword (unsigned)
access: read only
mechanism: by reference

Address of a longword containing the persona identification to which \$PERSONA_CREATE_EXTENSION attaches a new persona extension.

Two special values for *persona* are also permitted: 0, which means the current persona, and -1, which means the process' natural persona is used.

extensionID

OpenVMS usage: extension_ID
type: longword (unsigned)
access: read only
mechanism: by reference

Address of a longword containing the extension identification (EID) for which the registered CREATE routine will be called to create a new persona extension block.

buffer

OpenVMS usage: address
type: longword (unsigned)
access: read only
mechanism: by reference

Address of a buffer containing data to be used in creating the persona extension data structure. The interpretation of the data within this buffer is the responsibility of the extension create routine. For example, this data could be a Type-Length-Value (TLV) structure containing fields in the extension data structure. Specifying this buffer is optional; a caller who does not want to supply a buffer should specify an address of zero (0).

length

OpenVMS usage: size
type: longword (unsigned)
access: read only
mechanism: by reference

Address of a longword containing the size, in bytes, of the *buffer* argument. Specifying *length* is optional; a caller who does not want to supply a length should specify an address of zero (0). Specifying a buffer without a length is the same as not specifying a buffer.

flags

OpenVMS usage: flags
type: longword (unsigned)
access: read only
mechanism: by reference

Flag mask specifying the options to be employed when the persona extension is created. Specifying flags is optional; a caller who does not want to supply flags should specify an address of zero (0).

Flag	Description
PXB\$V_PRIMARY_EXTENSION	This extension is recorded as the persona's primary extension. If a persona already has a primary extension, the error SS\$_UNSUPPORTED is returned and the extension is not created. The primary extension is returned when the persona is queried for its "Primary Extension." There is no other meaning for this value.

Description

This service creates an extension by calling the registered Extension Create routine for the specified extension and by attaching it to the persona represented by the persona argument.

When a return fails, no persona extension is created.

A VMS extension is already associated with every persona. An attempt to create a VMS extension using this service returns SS\$_DUPLNAM.

Required Access or Privileges

This service requires that the caller have the IMPERSONATE privilege enabled or be in exec or kernel mode.

Required Quota

BYTLM

Related Services

\$PERSONA_ASSUME, \$PERSONA_CLONE, \$PERSONA_CREATE,
\$PERSONA_DELETE_EXTENSION, \$PERSONA_DELEGATE, \$PERSONA_DELETE,
\$PERSONA_EXTENSION_LOOKUP, \$PERSONA_FIND, \$PERSONA_MODIFY,
\$PERSONA_QUERY, \$PERSONA_RESERVE

Condition Values Returned

SS\$_NORMAL

The service completed successfully.

SS\$_ACCVIO

A buffer or return address specified in the item list cannot be read.

SS\$_BADITMCOD

The item list contains an invalid identifier code.

SS\$_BADPARAM

An invalid parameter was specified.

SS\$_DUPLNAM

The persona already has an extension of this type.

SS\$_EXQUOTA

The caller lacks sufficient quota to allocate a new persona.

SS\$_NOIMPERSONATE

The caller does not have the privilege to extend its original identity/persona.

SS\$_NOSUCHEXT

The extension requested does not exist on the system.

SS\$_PERSONANONGRATA

The persona ID supplied was invalid.

SS\$_UNSUPPORTED

An unsupported request was made; check the PRIMARY_EXTENSION flags bit.

\$PERSONA_DELEGATE (Alpha and Integrity servers)

Delegate Persona to a Server Process — On Alpha and Integrity server systems, delegates or assigns the currently active persona to another process.

Format

```
SYS$PERSONA_DELEGATE serverPID ,persona ,input
```

C Prototype

```
int sys$persona_delegate  
    (unsigned int *serverPID, unsigned int *persona, unsigned int *input);
```

Arguments

serverPID

OpenVMS usage: process_ID
type: longword (unsigned)
access: read only
mechanism: by reference

Address of a longword containing the extended process identification (PID) of the server process to which \$PERSONA_DELEGATE grants the current persona.

persona

OpenVMS usage: persona
type: longword (unsigned)
access: read only
mechanism: by reference

Address of a longword containing the identification that the \$PERSONA_RESERVE service reserved in the server's process for this client's persona.

input

OpenVMS usage: persona
type: longword (unsigned)
access: read only
mechanism: by reference

Address of a longword containing the persona identification that describes which persona is delegated to the server. If the *input* argument is zero (0) or null, or if the input value is zero (0), the current persona is delegated. If the input value is -1, then the natural persona of the process is delegated.

Description

This service delegates or assigns either the specified persona or the currently active persona to another process. The server process must have reserved a persona slot for the current process to use by calling `$PERSONA_RESERVE` before calling this service.

The delegation of persona is only supported for processes residing on the same node in the cluster. When a return fails, the persona is not delegated.

Required Access or Privileges

None

Required Quota

BYTLM

Related Services

`$PERSONA_ASSUME`, `$PERSONA_CLONE`, `$PERSONA_CREATE`,
`$PERSONA_CREATE_EXTENSION`, `$PERSONA_DELETE_EXTENSION`, `$PERSONA_DELETE`,
`$PERSONA_EXTENSION_LOOKUP`, `$PERSONA_FIND`, `$PERSONA_MODIFY`,
`$PERSONA_QUERY`, `$PERSONA_RESERVE`

Condition Values Returned

`SS$_NORMAL`

The service completed successfully.

`SS$_ACCVIO`

The arguments cannot be read by the service.

`SS$_BADPARAM`

An invalid parameter was specified.

`SS$_EXQUOTA`

The caller lacks sufficient quota to allocate a new persona.

`SS$_NONEXPR`

The process specified does not exist.

`SS$_PERSONANONGRATA`

The persona ID supplied was invalid.

`$PERSONA_DELETE`

Delete Persona — Deletes a persona created using the `$PERSONA_CREATE`, the `$PERSONA_CLONE`, or the `$PERSONA_RESERVE` service.

Format

SYS\$PERSONA_DELETE *persona*

C Prototype

```
int sys$persona_delete (unsigned int *persona);
```

Arguments

persona

OpenVMS usage: *persona*
type: longword (unsigned)
access: read only
mechanism: by reference

Address of a longword in which the *persona* identification handle is expected.

Description

The PERSONA_DELETE service frees the resources used by the *persona*. No changes to the caller's process are made as a result of calling \$PERSONA_DELETE.

The *persona* argument is validated against the caller's mode, so an invalid argument can cause an access violation to be signaled.

Required Access or Privileges

None

Required Quota

BYTLM

Related Services

\$PERSONA_ASSUME, \$PERSONA_CLONE, \$PERSONA_CREATE,
\$PERSONA_CREATE_EXTENSION, \$PERSONA_DELETE_EXTENSION,
\$PERSONA_DELEGATE, \$PERSONA_EXTENSION_LOOKUP, \$PERSONA_FIND,
\$PERSONA_MODIFY, \$PERSONA_QUERY, \$PERSONA_RESERVE

Condition Values Returned

SS\$_NORMAL

The service completed successfully

SS\$_ACCVIO

Access violation.

SS\$_PERSONADELPEND

Persona is in use; delete pending on release.

SS\$_NODELPERMANENT

Permanent personae cannot be deleted.

\$PERSONA_DELETE_EXTENSION (Alpha and Integrity servers)

Delete Persona Extension — On Alpha and Integrity server systems, deletes an extension attached to a persona.

Format

```
SYS$PERSONA_DELETE_EXTENSION persona ,extensionID
```

C Prototype

```
int sys$persona_delete_extension  
    (unsigned int *persona, unsigned int *extensionID);
```

Arguments

persona

OpenVMS usage: persona
type: longword (unsigned)
access: read only
mechanism: by reference

Address of a longword containing the persona identification for which \$PERSONA_DELETE_EXTENSION calls the registered Extension Delete function.

extensionID

OpenVMS usage: extension_ID
type: longword (unsigned)
access: read only
mechanism: by reference

Address of a longword containing the extension identification (EID) for which the registered DELETE routine is called in order to delete a persona extension block from the specified persona.

Description

This service deletes an extension data structure by calling the registered Extension Delete routine for the specified extension.

When a return fails, the persona extension is not deleted.

The VMS extension associated with each persona cannot be deleted. An attempt to delete that extension returns `SS$_UNSUPPORTED`.

Required Access or Privileges

This service requires that the caller have the `IMPERSONATE` privilege enabled or be in exec or kernel mode.

Required Quota

BYTLM

Related Services

`$PERSONA_ASSUME`, `$PERSONA_CLONE`, `$PERSONA_CREATE`,
`$PERSONA_CREATE_EXTENSION`, `$PERSONA_DELEGATE`, `$PERSONA_DELETE`,
`$PERSONA_EXTENSION_LOOKUP`, `$PERSONA_FIND`, `$PERSONA_MODIFY`,
`$PERSONA_QUERY`, `$PERSONA_RESERVE`

Condition Values Returned

`SS$_NORMAL`

The service completed successfully.

`SS$_BADPARAM`

An invalid parameter was specified.

`SS$_NOIMPERSONATE`

The caller does not have the privilege to delete pieces of the thread's original identity/persona.

`SS$_NOSUCHEXT`

The extension specified does not exist in the persona.

`SS$_PERSONANONGRATA`

The persona ID supplied was invalid.

`SS$_UNSUPPORTED`

The specified extension cannot be deleted.

`$PERSONA_EXTENSION_LOOKUP` (Alpha and Integrity servers)

Translates an Extension Name — On Alpha and Integrity server systems, translates a text name of an extension (for example, VMS or NT) into an extension identification (EID) that can be used in other persona-related system services.

Format

```
SYSS$PERSONA_EXTENSION_LOOKUP extensionName ,extensionID
```

C Prototype

```
int sys$persona_extension_lookup  
    (void *extensionName, unsigned int *extensionID);
```

Arguments

extensionName

OpenVMS usage: extension_name
type: character-coded text string
access: read only
mechanism: by descriptor – fixed-length descriptor

Address of a character string descriptor pointing to the name of the extension being looked up.

extensionID

OpenVMS usage: extension_ID
type: longword (unsigned)
access: write only
mechanism: by reference

Address of a longword into which the value of the extension identification (EID) returned by the service is written.

Description

This service translates a text name of an extension into an extension identification (EID) that can be used in other persona-related system services.

There are currently two extension names: VMS and NT.

Required Access or Privileges

None

Required Quota

None

Related Services

\$PERSONA_ASSUME, \$PERSONA_CLONE, \$PERSONA_CREATE,
\$PERSONA_CREATE_EXTENSION, \$PERSONA_DELETE_EXTENSION,
\$PERSONA_DELEGATE, \$PERSONA_DELETE, \$PERSONA_FIND, \$PERSONA_MODIFY,
\$PERSONA_QUERY, \$PERSONA_RESERVE

Condition Values Returned

SS\$_NORMAL

The service completed successfully.

SS\$_ACCVIO

The string descriptor supplied in the *extensionName* argument cannot be read by the service.

SS\$_BADPARAM

An invalid argument was specified.

SS\$_NOSUCHEXT

The supplied *extensionName* does not exist on this system.

\$PERSONA_FIND (Alpha and Integrity servers)

Find Persona with Characteristics — On Alpha and Integrity server systems, enables the caller to find the personae within a process that have certain attributes or settings.

Format

```
SYS$PERSONA_FIND persona ,itmlst ,contxt
```

C Prototype

```
int sys$persona_find  
    (unsigned int *persona, void *itmlst, unsigned int *contxt);
```

Arguments

persona

OpenVMS usage: persona
type: longword (unsigned)
access: write only
mechanism: by reference

Address of a longword into which the persona identification that matches all of the items present in the item list is written.

itmlst

OpenVMS usage: item_list_3
type: longword (unsigned)
access: read only
mechanism: by reference

Attributes specifying which information about the persona is to be compared. The *itmlst* argument is the address of a list of item descriptors, each describing an item of information or an item list processing directive. The list of item descriptors is terminated by a longword value of 0.

The following diagram shows the format of a single item descriptor:

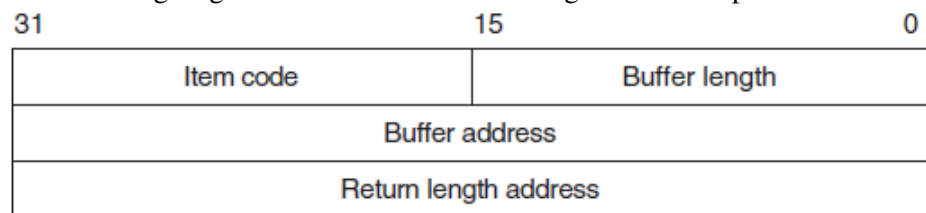

ZK-5186A-GE

The following table lists the item descriptor fields and their definitions:

Field	Description
Buffer length	A word containing a user-supplied integer specifying the length (in bytes) of the buffer in which \$PERSONA_FIND is to locate the information. The length of the buffer depends on the item code specified in the item code field of the item descriptor. If the value of buffer length is too small, \$PERSONA_FIND fails the comparison.
Item code	A word containing a user-supplied symbolic code specifying the item of information \$PERSONA_FIND is to test, or specifying a directive for processing subsequent items. The \$ISSDEF macro defines these codes. Each item code is described in the Description section.
Buffer address	A longword containing the user-supplied address of the buffer in which \$PERSONA_FIND locates the information used for the comparison.
Return length address	An unused longword containing the user-supplied address of a word into which the system service writes the length in bytes of the information it returned. This longword is unused for PERSONA_FIND.

contxt

OpenVMS usage: context
 type: longword (unsigned)
 access: modify
 mechanism: by reference

Context value used when repeatedly calling \$PERSONA_FIND. The *contxt* argument is the address of a longword used while \$PERSONA_FIND searches for all personae that match the criteria. The context value must be initialized to zero, and the resulting context of each call to \$PERSONA_FIND must be presented to each subsequent call. After *contxt* is passed to \$PERSONA_FIND, you must not modify its value.

Description

This service enables the caller to find the personae within a process that have certain attributes or settings.

A persona identification is returned only if all the items specified in the item list match those in the persona and its extensions.

The item list cannot be changed between context-saved calls. Results are unpredictable if the item list is changed between calls.

Repeated calls to \$PERSONA_FIND return subsequent matching personae. When the service returns SS\$_NOMOREPROC, there are no more personae to examine.

OpenVMS Persona Item Codes

The following table contains the item codes specific to the OpenVMS persona extension data:

Item Code	Use ¹	Size (bytes)	Description
ISS\$_USERNAME	Q,M,F	32	OpenVMS user name as text string
ISS\$_ACCOUNT	Q,M,F	32	OpenVMS account name as text string
ISS\$_DOMAIN	Q,F	32	OpenVMS SCSNODE as text string as obtained from \$GETJPI's nodename
ISS\$_PRINCIPAL	Q,F	64	OpenVMS user name as text string
ISS\$_EXTENSION	Q,F	32	The text string VMS
ISS\$_WORKPRIV	Q,M	8	Working privilege mask
ISS\$_WORKCLASS	Q,M	Varying	Working classification
ISS\$_RIGHTS	Q	Varying	Enabled list of rights identifiers
ISS\$_NOAUDIT	Q,M	4	No audit counter---0 means audits disabled
ISS\$_UIC	Q,M,F	4	Current UIC
ISS\$_AUTHPRIV	Q,M	8	Authorized privilege mask
ISS\$_PERMPRIV	Q,M	8	Permanent privilege mask
ISS\$_IMAGE_WORKPRIV	Q,M	8	Image working privilege mask
ISS\$_ENABLED	Q	4	Mask of enabled rights chains
ISS\$_AUTHRIGHTS	Q	Varying	Authorized list of rights identifiers
ISS\$_MINCLASS	Q	Varying	Minimum classification
ISS\$_MAXCLASS	Q	Varying	Maximum classification

¹Use descriptions are: Query, Modify, and Find.

Required Access or Privileges

The caller may require extension-specific privileges to search on some data items. The Persona Item Codes section lists the privileges that are needed.

Required Quota

None

Related Services

\$PERSONA_ASSUME, \$PERSONA_CLONE, \$PERSONA_CREATE, \$PERSONA_CREATE_EXTENSION, \$PERSONA_DELETE_EXTENSION,

`$PERSONA_DELEGATE`, `$PERSONA_DELETE`, `$PERSONA_EXTENSION_LOOKUP`,
`$PERSONA_MODIFY`, `$PERSONA_QUERY`, `$PERSONA_RESERVE`

Condition Values Returned

SS\$_NORMAL

The service completed successfully.

SS\$_ACCVIO

The item list cannot be read by the caller.

SS\$_BADPARAM

An invalid parameter was specified.

SS\$_BADITMCOD

The item list contains an invalid item code.

SS\$_BADCONTEXT

The context value is invalid.

SS\$_NOIMPERSONATE

The caller does not have the privilege to obtain information about the specified personae.

SS\$_NOMOREPROC

There are no more personae to check.

SS\$_NOSUCHEXT

The extension requested does not exist on the system.

`$PERSONA_MODIFY` (Alpha and Integrity servers)

Modify Persona Data — On Alpha and Integrity server systems, sets attribute values for a persona.

Format

```
SYS$PERSONA_MODIFY persona ,itmlst
```

C Prototype

```
int sys$persona_modify (unsigned int *persona, void *itmlst);
```

Arguments

persona

OpenVMS usage: `persona`

type: longword (unsigned)
 access: read only
 mechanism: by reference

Address of a longword containing the persona identification for which this service is to set information.

itmlst

OpenVMS usage: item_list_3
 type: longword (unsigned)
 access: read only
 mechanism: by reference

Attributes specifying which information in the persona is to be modified. The *itmlst* argument is the address of a list of item descriptors, each describing an item of information or an item list processing directive. The list of item descriptors is terminated by a longword value of 0.

The following diagram shows the format of a single item descriptor:

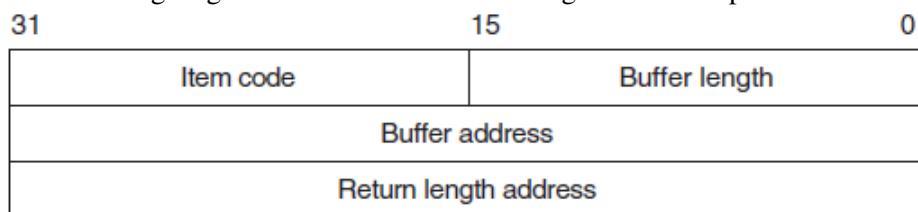

ZK-5186A-GE

The following table lists the item descriptor fields and their definitions:

Field	Description
Buffer length	A word containing a user-supplied integer specifying the length (in bytes) of the buffer from which \$PERSONA_MODIFY is to get information.
Item code	A word containing a user-supplied symbolic code specifying the item of information \$PERSONA_MODIFY is to change, or specifying a directive for processing subsequent items. The \$ISSDEF macro defines these codes. Each item code is described in the Description section.
Buffer address	A longword containing the user-supplied address of the buffer from which \$PERSONA_MODIFY is to get the information.
Return length address	This field is ignored on a call to PERSONA_MODIFY.

Description

The Modify Persona Data service sets attribute values for a persona.

OpenVMS Persona Item Codes

The following table contains the item codes specific to the OpenVMS persona extension data:

Item Code	Use ¹	Size (bytes)	Description
ISS\$_USERNAME	Q,M,F	32	OpenVMS user name as text string

Item Code	Use ¹	Size (bytes)	Description
ISS\$_ACCOUNT	Q,M,F	32	OpenVMS account name as text string
ISS\$_DOMAIN	Q,F	32	OpenVMS SCSNODE as text string as obtained from \$GETJPI's nodename
ISS\$_PRINCIPAL	Q,F	64	OpenVMS user name as text string
ISS\$_EXTENSION	Q,F	32	The text string VMS
ISS\$_WORKPRIV	Q,M	8	Working privilege mask
ISS\$_WORKCLASS	Q,M	Varying	Working classification
ISS\$_RIGHTS	Q	Varying	Enabled list of rights identifiers
ISS\$_NOAUDIT	Q,M	4	No audit counter---0 means audits disabled
ISS\$_UIC	Q,M,F	4	Current UIC
ISS\$_AUTHPRIV	Q,M	8	Authorized privilege mask
ISS\$_PERMPRIV	Q,M	8	Permanent privilege mask
ISS\$_IMAGE_WORKPRIV	Q,M	8	Image working privilege mask
ISS\$_ENABLED	Q	4	Mask of enabled rights chains
ISS\$_AUTHRIGHTS	Q	Varying	Authorized list of rights identifiers
ISS\$_MINCLASS	Q	Varying	Minimum classification
ISS\$_MAXCLASS	Q	Varying	Maximum classification

¹Use descriptions are: Query, Modify, and Find.

Required Access or Privileges

This service requires that the caller have the IMPERSONATE privilege enabled or be in exec or kernel mode.

Required Quota

None

Related Services

\$PERSONA_ASSUME, \$PERSONA_CLONE, \$PERSONA_CREATE, \$PERSONA_CREATE_EXTENSION, \$PERSONA_DELETE_EXTENSION, \$PERSONA_DELEGATE, \$PERSONA_DELETE, \$PERSONA_EXTENSION_LOOKUP, \$PERSONA_FIND, \$PERSONA_QUERY, \$PERSONA_RESERVE

Condition Values Returned

SS\$_NORMAL

The service completed successfully.

SS\$_ACCVIO

The item list cannot be read by the caller, or the buffer cannot be read by the caller.

SS\$_BADPARAM

An invalid parameter was specified.

SS\$_BADITMCOD

The item list contains an invalid item code.

SS\$_NOIMPERSONATE

The caller does not have the privilege to obtain information about the specified personae.

SS\$_NOSUCHEXT

The extension requested does not exist on the system.

SS\$_PERSONANONGRATA

The persona ID supplied was invalid. This service may also return status codes associated with the various extension routines.

\$PERSONA_QUERY (Alpha and Integrity servers)

Query for Persona Data — On Alpha and Integrity server systems, retrieves attribute values from a persona (and accompanying extensions).

Format

```
SYS$PERSONA_QUERY persona ,itmlst
```

C Prototype

```
int sys$persona_query (unsigned int *persona, void *itmlst);
```

Arguments

persona

OpenVMS usage: persona
type: longword (unsigned)
access: read only
mechanism: by reference

Address of a longword into which the persona identification handle is written.

Two special values for *persona* are also permitted: 0, which means use the current persona, and -1, which means use the process' natural persona.

itmlst

OpenVMS usage: item_list_3

type: longword (unsigned)
 access: read only
 mechanism: by reference

Attributes describing which information about the persona is to be returned. The *itmlst* argument is the address of a list of item descriptors, each of which describes an item of information or an item list processing directive. The list of item descriptors is terminated by a longword value of 0.

The following diagram shows the format of a single item descriptor:

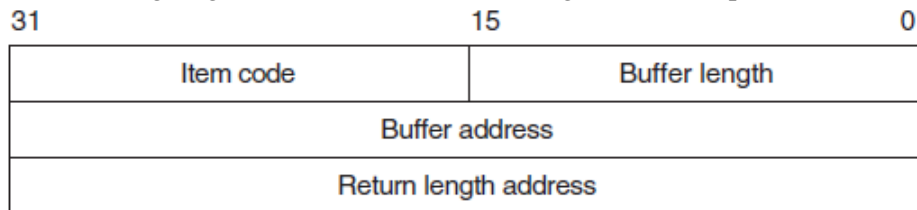

ZK-5186A-GE

The following table lists the item field descriptors and their definitions:

Field	Description
Buffer length	A word containing a user-supplied integer specifying the length (in bytes) of the buffer into which \$PERSONA_QUERY writes the information. The length of the buffer depends on the item code specified in the item code field of the item descriptor. If the value of buffer length is too small, \$PERSONA_QUERY truncates the data. If the buffer length is specified as 0, the service does not return any data in the buffer; instead, the service returns the size of buffer required to contain the data in the Return Length address. This allows run-time determination of the size of buffer needed to hold the requested information.
Item code	A word containing a user-supplied symbolic code specifying the item of information \$PERSONA_QUERY is to return, or specifying a directive for processing subsequent items. The \$ISSDEF macro defines these codes. Each item code is described in the Description section.
Buffer address	A longword containing the user-supplied address of the buffer into which \$PERSONA_QUERY writes the information.
Return length address	A longword containing the user-supplied address of a word into which the service writes the length in bytes of the information it returned. If the buffer length field is zero (0), then you must specify a return length address.

Description

The Query for Persona Data service returns the requested items in the buffers supplied.

OpenVMS Persona Item Codes

The following table contains the item codes specific to the OpenVMS persona extension data:

Item Code	Use ¹	Size (bytes)	Description
ISS\$_USERNAME	Q,M,F	32	OpenVMS user name as text string
ISS\$_ACCOUNT	Q,M,F	32	OpenVMS account name as text string

Item Code	Use ¹	Size (bytes)	Description
ISS\$_DOMAIN	Q,F	32	OpenVMS SCSNODE as text string as obtained from \$GETJPI's nodename
ISS\$_PRINCIPAL	Q,F	64	OpenVMS user name as text string
ISS\$_EXTENSION	Q,F	32	The text string VMS
ISS\$_WORKPRIV	Q,M	8	Working privilege mask
ISS\$_WORKCLASS	Q,M	Varying	Working classification
ISS\$_RIGHTS	Q	Varying	Enabled list of rights identifiers
ISS\$_NOAUDIT	Q,M	4	No audit counter---0 means audits disabled
ISS\$_UIC	Q,M,F	4	Current UIC
ISS\$_AUTHPRIV	Q,M	8	Authorized privilege mask
ISS\$_PERMPRIV	Q,M	8	Permanent privilege mask
ISS\$_IMAGE_WORKPRIV	Q,M	8	Image working privilege mask
ISS\$_ENABLED	Q	4	Mask of enabled rights chains
ISS\$_AUTHRIGHTS	Q	Varying	Authorized list of rights identifiers
ISS\$_MINCLASS	Q	Varying	Minimum classification
ISS\$_MAXCLASS	Q	Varying	Maximum classification

¹Use descriptions are: Query, Modify, and Find.

Common Item Codes

The following table contains the item codes specific to the common persona extension data:

Item Code	Use ¹	Size (bytes)	Description
ISS\$_COMMON_USERNAME	Q	varying	User name as text string
ISS\$_COMMON_ACCOUNT	Q	varying	Account name as text string
ISS\$_COMMON_FLAGS	Q	4	Flags as a longword
ISS\$_DOMAIN	Q	varying	Domain name as text string
ISS\$_COMMON_PRINCIPAL	Q	varying	Principal name as text string
ISS\$_EXTENSION	Q	32	Extension name as text string
ISS\$_DOI	Q	8	Domain Of Interpretation quadword

¹Use descriptions are: Query, Modify, and Find.

General Persona Item Codes

The following table contains the item codes specific to the general persona extension data:

Item Code	Use ¹	Size (bytes)	Description
ISS\$_SWITCH_EXTENSION	Q,M	4	Extension ID to be used for subsequent item code processing
ISS\$_FLAGS	Q,M	4	Various flags (ISS\$_FLAG_PERMANENT)

Item Code	Use ¹	Size (bytes)	Description
ISS\$_MODE	Q	4	Persona creation mode (user, supervisor, exec, or kernel)
ISS\$_UID	Q	16	UID assigned when persona created
ISS\$_PERSONA_ID	Q	4	Persona ID of this PSB
ISS\$_PRIMARY_EXTENSION	Q,M	4	Extension id of primary authenticator
ISS\$_EXTENSION_COUNT	Q	4	Count of extensions attached to persona
ISS\$_EXTENSION_ARRAY	Q	varying	Array of longwords containing extension ids of all extensions attached to persona

¹Use descriptions are: Query, Modify, and Find.

NT Persona Item Codes

The following table contains the item codes specific to the NT persona extension data:

Item Code	Use ¹	Size (bytes)	Description
ISS\$_NT_PRINCIPAL	Q,F	varying	Principal name as text string
ISS\$_NT_TOKEN_USERNAME	Q,F	varying	NT user name as text string
ISS\$_NT_TOKEN_DOMAINNAME	Q,F	varying	NT domain as text string
ISS\$_EXTENSION	Q,F	varying	The text string "NT"
ISS\$_NT_FLAGS	Q,M	4	Various flags
ISS\$_NT_USER_REFCOUNT	Q,M	4	NT-Specific User Field
ISS\$_NT_CREDENTIALS	Q,M	varying	All Token and Security info
ISS\$_NT_NT_OWF_PASSWORD	Q,M	varying	NT Password
ISS\$_NT_LM_OWF_PASSWORD	Q,M	varying	LM Password
ISS\$_NT_TOKEN_USERSESSIONKEY	Q,F	16	User's session key
ISS\$_NT_TOKEN_LMSESSIONKEY	Q,F	8	LM session key

¹Use descriptions are: Query, Modify, and Find.

Required Access or Privileges

No privileges are required to call this service.

Required Quota

None

Related Services

\$PERSONA_ASSUME, \$PERSONA_CLONE, \$PERSONA_CREATE, \$PERSONA_CREATE_EXTENSION, \$PERSONA_DELETE_EXTENSION, \$PERSONA_DELEGATE, \$PERSONA_DELETE, \$PERSONA_EXTENSION_LOOKUP, \$PERSONA_FIND, \$PERSONA_MODIFY, \$PERSONA_RESERVE

Condition Values Returned

SS\$_NORMAL

The service completed successfully.

SS\$_ACCVIO

The item list cannot be read by the caller, or the buffer length or buffer cannot be written by the caller.

SS\$_BADPARAM

An invalid parameter was specified.

SS\$_BADITMCO

The item list contains an invalid item code.

SS\$_NOSUCHEXT

The extension requested does not exist on the system.

SS\$_PERSONANONGRATA

The persona ID supplied is invalid.

\$PERSONA_RESERVE (Alpha and Integrity servers)

Reserve Persona Slot — On Alpha and Integrity server systems, reserves a persona ID in the server's persona table to be filled in by the \$PERSONA_DELEGATE system service.

Format

```
SYS$PERSONA_RESERVE clientPID ,persona
```

C Prototype

```
int sys$persona_reserve (unsigned int *clientPID, unsigned int *persona);
```

Arguments

clientPID

OpenVMS usage: process_ID
type: longword (unsigned)
access: read only
mechanism: by reference

Address of a longword containing the External Process Identification (EPID) of the client process for which the server is reserving the slot.

persona

OpenVMS usage: persona
type: longword (unsigned)
access: write only
mechanism: by reference

Address of a longword into which the persona identification is written. This service sets aside the identification for the client's to-be-delegated persona.

Description

This service reserves a persona identifier slot within the current process for a specific client process to use in delegating its persona to this process. A reserved persona slot can be deleted by a call to the \$PERSONA_DELETE service. When a return fails, no persona slot has been reserved for the client process.

The delegation of persona is only supported for processes residing on the same node of a cluster.

Required Access or Privileges

IMPERSONATE

Required Quota

BYTLM

Related Services

\$PERSONA_ASSUME, \$PERSONA_CLONE, \$PERSONA_CREATE,
\$PERSONA_CREATE_EXTENSION, \$PERSONA_DELETE_EXTENSION,
\$PERSONA_DELEGATE, \$PERSONA_DELETE, \$PERSONA_EXTENSION_LOOKUP,
\$PERSONA_FIND, \$PERSONA_MODIFY

Condition Values Returned

SS\$_NORMAL

The service completed successfully.

SS\$_ACCVIO

The item list cannot be read by the caller.

SS\$_BADPARAM

An invalid parameter was specified.

SS\$_EXQUOTA

The caller lacks sufficient quota to allocate a new persona.

SS\$_NONEXPR

The specified process does not exist, or an invalid process identification was specified.

\$POWER_CONTROL

Power Control — Manipulates the platform's power and performance settings to the value specified in the `power_setting` parameter. This applies to the entire system just as though commanded through the Integrated Lights-Out (iLO) web interface.

Format

```
SYSPower_CONTROL power_setting, current_value
```

C Prototype

```
int sys$power_control  
    unsigned __int64 power_setting, unsigned __int64 *current_value;
```

Arguments

power_setting

OpenVMS usage: quadword_unsigned
type: quadword (unsigned)
access: write only
mechanism: by 64-bit value

A quadword value to specify the new power or performance setting.

current_value

OpenVMS usage: quadword_unsigned
type: quadword (unsigned)
access: read only
mechanism: by 64-bit value

The address of a quadword for the service to return the current setting (optional).

Description

Power control on Integrity servers comprises power saving strategies and a means of commanding a strategy to be used. The various means of commanding include iLO web interface, Insight Power Manager (IPM), and EFI command line.

Regardless of the interface used (iLO web interface, IPM, or EFI command line), iLO commanding can specify one of the following four states:

- Operate at the highest possible performance ("High Performance Mode")
- Operate using the least possible power ("Low Power Mode")

- Operate using some efficient compromise between power and performance ("Efficiency Mode")
- Give power control over to some OS-defined method ("OS Control")

"OS Control Mode", including platforms which have no iLO power commands, is implemented on OpenVMS by the system service \$POWER_CONTROL.

This service can be used on all Integrity server platforms.

Power Setting—Enumerated values are as follows:

- POWER\$C_HIGHEST_PERF---Similar to the iLO 'highest performance' command
- POWER\$C_LOWEST_POWER---Similar to the iLO 'lowest power' command
- POWER\$C_EFFICIENCY---Similar to the iLO 'efficiency' command

Previous Value (Optional)---Returns the previous power control state.

Additional values can be added to provide finer control than is possible with the iLO command, but they are not implemented initially.

Required Access or Privileges

This service requires WORLD privilege.

Related Quota

None

Related Services

None

Condition Values Returned

SS\$_NORMAL

The requested action is performed.

SS\$_WRONGSTATE

The platform power state is not set to OS control.

SS\$_ACCVIO

The address specified by current_value is not writable.

SS\$_BADPARAM

The value of power_setting is not a legal value.

SS\$_NOWORLD

The user does not have the WORLD privilege, which is required to use this service.

\$PROCESS_AFFINITY (Alpha and Integrity servers)

Modify Process Affinity — On Alpha and Integrity server systems, allows modification of the CPU affinity set for a specified kernel thread. This service accepts 64-bit addresses.

Format

```
SYS$PROCESS_AFFINITY
    [pidadr], [prcnam], [select_mask], [modify_mask], [prev_mask],
    [flags] [, [mask_length]]
```

C Prototype

```
int sys$process_affinity
    (unsigned int *pidadr, void *prcnam, struct _generic_64 *select_mask,
     struct _generic_64 *modify_mask, struct _generic_64 *prev_mask,
     struct _generic_64 *flags, ...);
```

Arguments

pidadr

OpenVMS usage: process_id
type: longword (unsigned)
access: read only
mechanism: by 32- or 64-bit reference

Process identification (PID) of a kernel thread whose affinity mask is to be modified or returned. The *pidadr* argument is the 32- or 64-bit address of a longword that contains the PID.

Process selection is made through a combination of the *pidadr* and *prcnam* arguments. If neither are specified or if both have a zero value, the service operations are made to the user affinity mask of the current kernel thread of the calling process. The *pidadr* argument takes precedence over the *prcnam* argument in any circumstances where both are supplied in the service call.

prcnam

OpenVMS usage: process_name
type: character-coded text string
access: read only
mechanism: by 32- or 64-bit descriptor–fixed-length string descriptor

Process name of the process whose affinity mask is to be modified or returned. The *prcnam* argument is the 32- or 64-bit address of a character string descriptor pointing to the process name string. A process can be identified with a 1- to 15-character string. The service operations are made to the user affinity mask of the initial thread of the specified process.

If *pidadr* and *prcnam* are both specified, then *pidadr* is modified or returned and *prcnam* is ignored. If neither argument is specified, then the context of the current kernel thread of the calling process is modified or returned.

select_mask

OpenVMS usage: bitmap
type: quadword bitmap
access: read only
mechanism: by 32- or 64-bit reference

The *select_mask* argument specifies which bits of the specified process's affinity mask are to be modified. The *select_mask* argument is the 32- or 64-bit address of a quadword bit vector wherein a bit, when set, specifies that the corresponding CPU position in the mask is to be modified.

modify_mask

OpenVMS usage: bitmap
type: quadword bitmap
access: read only
mechanism: by 32- or 64-bit reference

Mask specifying the settings for those explicit affinities selected in the *select_mask* argument. The *modify_mask* argument is the 32- or 64-bit address of a quadword bit vector wherein a bit, when set, specifies that the corresponding CPU is to be added to the specified process affinity set; when clear, the corresponding CPU is to be removed from the specified process affinity set.

To add a specific CPU to the affinity mask set, that bit position must be set in both *select_mask* and *modify_mask*. To remove a specific CPU from the affinity mask set, that bit position must be set in *select_mask* and clear in *modify_mask*.

The constant `CAP$K_ALL_CPU_ADD`, when specified in *modify_mask*, indicates that all CPUs specified in *select_mask* are to be added to the affinity mask set. The constant `CAP$K_ALL_CPU_REMOVE` indicates that all CPUs in *select_mask* are to be removed from the affinity mask set.

prev_mask

OpenVMS usage: bitmap
type: quadword bitmap
access: write only
mechanism: by 32- or 64-bit reference

Previous CPU affinity mask for the specified kernel thread before execution of this call to `$PROCESS_AFFINITY`. The *prev_mask* argument is the 32- or 64-bit address of a quadword into which `$PROCESS_AFFINITY` writes the previous explicit affinity bitmap.

flags

OpenVMS usage: mask_quadword
type: quadword (unsigned)

access: read only
mechanism: by 32- or 64-bit reference

Options selected for affinity modification. The *flags* argument is a quadword bit vector wherein a bit corresponds to an option. Only the bits specified below are used; the remainder of the quadword bits are reserved and must be 0.

Each option (bit) has a symbolic name, which the \$CAPDEF macro defines. The *flags* argument is constructed by performing a logical OR operation using the symbolic names of each desired option.

The following table describes the symbolic name of each option.

Symbolic Name	Description
CAP\$M_FLAG_PERMANENT	<p>Indicates whether to modify the permanent process affinities in addition to the current image copy. If CAP\$M_FLAG_PERMANENT is set, then both the permanent and current affinities are modified. If the flag bit is clear or <i>flags</i> is unspecified, then just the current image process affinities are modified.</p> <p>This bit also determines which of the affinity masks are returned in <i>prev_mask</i>. If set, the permanent mask, used to reinitialize the current set at image rundown, is returned. If the bit is clear or the <i>flags</i> argument is not specified, the current running mask is returned.</p>
CAP\$M_FLAG_CHECK_CPU	<p>Determines whether the kernel thread can be left in a non-runnable state under some circumstances. No operation of this service will allow a transition from a runnable to blocked state; however, if the kernel thread is already at a blocked state, this bit determines whether the result of the operation must leave it runnable. If CAP\$M_FLAG_CHECK_CPU is set or <i>flags</i> is unspecified, the kernel thread will be checked to ensure it can safely run on one of the CPUs in the active set; otherwise, any valid state operations on kernel threads already in a blocked state will be allowed.</p>
CAP\$M_FLAG_CHECK_CPU_ACTIVE	<p>Indicates whether a check is made to verify that all CPUs in the select mask that are about to be selected for affinity binding are in the active set. This does not apply to CPUs that are about to be cleared from the current affinity set. Unlike CAP\$M_FLAG_CHECK_CPU where only a single CPU has to be valid for the condition to pass, CAP\$M_FLAG_CHECK_CPU_ACTIVE requires that all CPUs in the selected set must pass the criteria.</p>
CAP\$M_PURGE_WS_IF_NEW_RAD	<p>Causes the working set of the process to be purged if the choice of affinity results in a change to the home RAD of the process.</p>

mask_length

OpenVMS usage: bitmap

type: quadword bitmap
access: read only
mechanism: by 32- or 64-bit reference

The *mask_length* specifies the length in bytes of each of the three bitmaps: *select_mask*, *modify_mask*, *prev_mask*. If *mask_length* is not supplied or specified as zero, a length of 8 bytes is used.

The correct value for *mask_length* is determined by the number of supported CPUs on the system. You can compute the number of bytes needed for the bitmap as follows: Use the \$GETSYI system service with an item code of SYI\$_MAX_CPUS to find the minimum number of bits needed, round this number up to a multiple of 64, and divide the result by 8.

Description

The Modify Process Affinity system service, based on the arguments *select_mask* and *modify_mask*, adds or removes CPUs from the specified kernel thread's affinity mask sets. If specified, the previous affinity mask is returned in *prev_mask*. With the *modify_mask* argument, multiple CPUs can be added or removed from the process affinity mask set in the same system service call.

Adding a specific CPU to the process affinity mask indicates that the kernel thread is able to execute only on that CPU or on the others specified in the mask. Affinity scheduling takes effect as soon as the affinity mask becomes nonzero, limiting the CPU selection for the kernel thread to what is specified and available. Thread selection and execution is still subject to standard capability requirements, but only the affinity CPU set is considered when looking for an available site. When the affinity mask is cleared, all CPUs are again considered available and affinity is deactivated.

Either *modify_mask* or *prev_mask*, or both, must be specified as arguments. If *modify_mask* is specified, then *select_mask* must be specified as an argument. If *modify_mask* is not specified, then no modifications are made to the affinity mask for the specified kernel thread. In this case, *select_mask* is ignored. If *prev_mask* is not specified, then no previous mask is returned.

No service changes will be allowed if the specified kernel thread will transition from a runnable to blocked state. The CAP\$M_FLAG_CHECK_CPU bit in the *flags* argument requires that the final thread state be runnable regardless of previous state; otherwise, interim changes that maintain a blocked state are allowed if the thread is already in one.

Required Privileges

The caller must have the ALTPRI privilege to call SYS\$PROCESS_AFFINITY to modify its own affinity mask. To modify another process' affinity mask, the caller must have:

ALTPRI—To modify any process with a matching UIC
ALTPRI and GROUP—To modify any process in the same UIC group
ALTPRI and WORLD—To modify any process

To call SYS\$PROCESS_AFFINITY simply to retrieve the specific process or global mask, the caller need only have the following privileges:

None—To retrieve the state of itself or any process with a matching UIC
GROUP—To retrieve the state of any process in the same UIC group
WORLD—To retrieve the state of any process

Related Services

\$CPU_CAPABILITIES

\$PROCESS_CAPABILITIES

Condition Values Returned

SS\$_NORMAL

The service completed successfully.

SS\$_BADPARAM

One or more arguments has an invalid value.

SS\$_ACCVIO

The service cannot access the locations specified by one or more arguments.

SS\$_NOPRIV

Insufficient privilege for attempted operation.

SS\$_NOSUCHTHREAD

The specified kernel thread does not exist.

SS\$_NONEXPR

The specified process does not exist, or an invalid process identification was specified.

SS\$_IVLOGNAM

The process name string has a length of 0 or has more than 15 characters.

SS\$_CPUCAP

No CPU can run the specified process with new affinities.

SS\$_INSFARG

Fewer than the required number of arguments were specified or no operation was specified.

\$PROCESS_CAPABILITIES (Alpha and Integrity servers)

Modify Process User Capabilities — On Alpha and Integrity server systems, allows modification of the user capability set for a specified kernel thread, or for the global user capability process default. This service accepts 64-bit addresses.

Format

SYS\$PROCESS_CAPABILITIES

```
[pidadr] [,prcnam] [,select_mask] [,modify_mask] [,prev_mask] [,flags]
```

C Prototype

```
int sys$process_capabilities  
    (unsigned int *pidadr, void *prcnam, struct _generic_64 *select_mask,  
     struct _generic_64 *modify_mask, struct _generic_64 *prev_mask,  
     struct _generic_64 *flags);
```

Arguments

pidadr

OpenVMS usage: process_id
type: longword (unsigned)
access: read only
mechanism: by 32- or 64-bit reference

Process identification (PID) of a kernel thread whose user capability mask is to be modified or returned. The *pidadr* argument is the 32- or 64-bit address of a longword that contains the PID.

Process selection is made through a combination of the *pidadr* and *prcnam* arguments. If neither are specified or if both have a zero value, the service operations are made to the user capability mask of the current kernel thread of the calling process. The *pidadr* argument takes precedence over the *prcnam* argument where both are supplied in the service call.

If the constant `CAP$M_FLAG_DEFAULT_ONLY` is specified in *flags*, then the user portion of the default process user capability mask is modified or returned instead, regardless of the values specified in *pidadr*.

prcnam

OpenVMS usage: process_name
type: character-coded text string
access: read only
mechanism: by 32- or 64-bit descriptor–fixed-length string descriptor

Process name of the process whose user capability mask is to be modified or returned. The *prcnam* argument is the 32- or 64-bit address of a character string descriptor pointing to the process name string. A process can be identified with a 1- to 15-character string. The service operations are made to the user capability mask of the initial thread of the specified process.

You can use the *prcnam* argument only if the process identified by the descriptor has the same UIC group number as the calling process. To obtain information about processes in other groups, the *pidadr* argument must be used.

If *pidadr* and *prcnam* are both specified, then *prcnam* is ignored. If neither argument is specified, then the context of the current kernel thread of the calling process is modified or returned.

select_mask

OpenVMS usage: mask_quadword

type: quadword (unsigned)
access: read only
mechanism: by 32- or 64-bit reference

Mask specifying which bits of the specified process' user capability mask are to be modified. The *select_mask* argument is the 32- or 64-bit address of a quadword bit vector wherein a bit, when set, specifies that the corresponding user capability is to be modified.

The individual user capability bits in *select_mask* can be referenced by their symbolic bit constant names, CAP\$M_USER1 through CAP\$M_USER16. These constants (not zero-relative) specify the position in the mask quadword that corresponds to the bit name. Multiple capabilities can be selected by ORing together the appropriate bits.

Alternatively, the constant CAP\$K_ALL_USER, when specified as the *select_mask* argument, selects all user capabilities.

modify_mask

OpenVMS usage: mask_quadword
type: quadword (unsigned)
access: read only
mechanism: by 32- or 64-bit reference

Mask specifying the settings for those capabilities selected in the *select_mask* argument. The *modify_mask* argument is the 32- or 64-bit address of a quadword bit vector wherein a bit, when set, specifies that the corresponding user capability is to be added to the specified kernel thread; when clear, the corresponding user capability is to be removed.

The symbolic bit constants CAP\$M_USER1 through CAP\$M_USER16 can be used to modify the appropriate bit position in *modify_mask*. Multiple capabilities can be modified by ORing together the appropriate bits.

To add a specific user capability to a kernel thread, that bit position must be set in both *select_mask* and *modify_mask*. To remove a specific user capability from a kernel thread, that bit position must be set in *select_mask* and clear in *modify_mask*.

The symbolic constant CAP\$K_ALL_USER_ADD, when specified in *modify_mask*, indicates that all capabilities specified in *select_mask* are to be added to the appropriate capability set. The symbolic constant CAP\$K_ALL_USER_REMOVE indicates that all specified capabilities are to be removed from the set.

prev_mask

OpenVMS usage: mask_quadword
type: quadword (unsigned)
access: write only
mechanism: by 32- or 64-bit reference

Previous user capability mask for the specified process or thread before execution of this call to \$PROCESS_CAPABILITIES. The *prev_mask* argument is the 32- or 64-bit address of a quadword into which \$PROCESS_CAPABILITIES writes the previous bit mask. If

CAP\$M_FLAG_DEFAULT_ONLY is set in the *flags* argument, then *prev_mask* will contain the user portion of the global default capability mask.

flags

OpenVMS usage: mask_quadword
 type: quadword (unsigned)
 access: read only
 mechanism: by 32- or 64-bit reference

Options selected for the user capability modification. The *flags* argument is a quadword bit vector wherein a bit corresponds to an option. Only the bits specified below are used; the remainder of the quadword bits are reserved and must be zero.

Each option (bit) has a symbolic name, defined by the \$CAPDEF macro. The *flags* argument is constructed by performing a logical OR operation using the symbolic names of each desired option.

The following table describes the symbolic name of each option.

Symbolic Name	Description
CAP\$M_FLAG_DEFAULT_ONLY	Indicates that the specified operations are to be performed on the global context cell instead of on a specific kernel thread. This bit supersedes any individual kernel thread specified in <i>pidadr</i> or <i>prcnam</i> . Specifying this bit constant applies the service operations to the capabilities for all newly created processes.
CAP\$M_FLAG_PERMANENT	Indicates whether to modify the permanent user process capabilities in addition to the current image copy. If CAP\$M_FLAG_PERMANENT is set, then both the permanent and current user process capabilities are modified. If this bit is clear or <i>flags</i> is unspecified, then just the current image process capabilities are modified. This bit also determines which of the capability masks are returned in <i>prev_mask</i> . If set, the permanent mask, used to reinitialize the current set at image rundown, is returned. If the bit is clear or the <i>flags</i> argument is not specified, the current running mask is returned.
CAP\$M_FLAG_CHECK_CPU	Determines whether the kernel thread can be left in a non-runnable state under some circumstances. No operation of this service will allow a transition from runnable to blocked state; however, if the kernel thread is already at a blocked state, this bit determines whether the result of the operation must leave it runnable. If CAP\$M_FLAG_CHECK_CPU is set or <i>flags</i> is unspecified, the kernel thread will be checked to ensure it can safely run on one of the CPUs in the active set; otherwise, any state operations on kernel threads already in a blocked state will be allowed.
CAP\$M_PURGE_WS_IF_NEW_RAD	Causes the working set of the process to be purged if the choice of capability results in a change to the home RAD of the process.

Description

The Modify Process User Capabilities system service, based on the arguments *select_mask* and *modify_mask*, adds or removes user capabilities for the specified kernel thread. If specified, the previous capability mask is returned in *prev_mask*. With the *modify_mask* argument, multiple user capabilities for a kernel thread can be added or removed in the same system service call.

Either *modify_mask* or *prev_mask*, or both, must be specified as arguments. If *modify_mask* is specified, then *select_mask* must be specified as an argument. If *modify_mask* is not specified, then no modifications are made to the user capability mask for the specified kernel thread. In this case, *select_mask* is ignored. If *prev_mask* is not specified, then no previous mask is returned.

No service changes will be allowed if the specified kernel thread will transition from a runnable to blocked state. The `CAP$M_FLAG_CHECK_CPU` bit in the *flags* argument requires that the final thread state be runnable regardless of previous state; otherwise, interim changes that maintain a blocked state are allowed if the thread is already in one.

If the symbolic bit constant `CAP$M_FLAG_DEFAULT_ONLY` is set in the *flags* argument, the user capability modifications or the mask read requests are made only to the global initialization cell regardless of what process selections values are specified in the *pidadr* and *prcnam* arguments.

Required Access or Privileges

The caller must have the `ALTPRI` privilege to call `SY$PROCESS_CAPABILITIES` to modify its own user capability mask. To modify another process' user capability mask, the caller must have:

`ALTPRI`—To modify any process with a matching UIC
`ALTPRI` and `GROUP`—To modify any process in the same UIC group
`ALTPRI` and `WORLD`—To modify any process

To call `SY$PROCESS_CAPABILITIES` simply to retrieve the specific process or global mask, the caller need only have the following privileges:

`None`—To retrieve the state of itself or any process with a matching UIC
`GROUP`—To retrieve the state of any process in the same UIC group
`WORLD`—To retrieve the state of any process

Related Services

`$CPU_CAPABILITIES`

Condition Values Returned

`SS$_NORMAL`

The service completed successfully.

`SS$_BADPARAM`

One of more arguments has an invalid value.

`SS$_ACCVIO`

The service cannot access the locations specified by one or more arguments.

SS\$_NOSUCHTHREAD

The specified kernel thread does not exist.

SS\$_NONEXPR

The specified process does not exist, or an invalid process identification was specified.

SS\$_IVLOGNAM

The process name string has a length of 0 or more than 15 characters.

SS\$_NOPRIV

Insufficient privilege for attempted operation.

SS\$_CPUCAP

No CPU can run the specified process with new capabilities.

SS\$_INSFARG

Fewer than the required number of arguments were specified or no operation was specified.

\$PROCESS_SCAN

Process Scan — Creates and initializes a process context that is used by \$GETJPI to scan processes on the local system or across the nodes in an OpenVMS Cluster system. On Alpha and Integrity server systems, this service accepts 64-bit addresses.

Format

```
SYS$PROCESS_SCAN pidctx [,itmlst]
```

C Prototype

```
int sys$process_scan (unsigned int *pidctx, void *itmlst);
```

Arguments

pidctx

OpenVMS usage:	process_id
type:	longword (unsigned)
access:	modify
mechanism:	by 32- or 64-bit reference (Alpha and Integrity servers)

Context value supplied by \$PROCESS_SCAN to be used as the *pidadr* argument of \$GETJPI. The *pidctx* argument is the 32- or 64-bit address (on Alpha and Integrity server systems) of a longword that is to receive the process context longword. This longword normally contains 0 or a previous context. If it contains a previous context, the old context is deleted. If it contains a value other than 0 or a previous context, the old value is ignored.

itmlst

OpenVMS usage: 32-bit `item_list_3` or 64-bit `item_list_64b`
 type: longword (unsigned) for 32-bit; quadword (unsigned) for 64-bit
 access: read only
 mechanism: by 32- or 64-bit reference (Alpha and Integrity servers)

Item list specifying selection criteria to be used by the scan or to control the scan.

The `itmlst` argument is the 32- or 64-bit address (on Alpha and Integrity server systems) of a list of item descriptors, each of which describes one selection criterion or control option. Within each selection criterion you can include several item entries. An item list in 32-bit format is terminated by a longword of 0; an item list in 64-bit format is terminated by a quadword of 0. All items in an item list must be of the same format—either 32-bit or 64-bit.

The information in the item list is passed to the item descriptor in one of two ways. If the item descriptor can always hold the actual value of the selection criterion, the value is placed in the second longword of the item descriptor and the buffer length is specified as 0. If the item descriptor points to the actual value of the selection criterion, the address of the value is placed in the second longword of the item descriptor and you must specify the buffer length for the selection criterion. Each item code description specifies whether the information is passed by value or by reference.

The following diagram depicts the format of a 32-bit item descriptor that passes the selection criterion as a value:

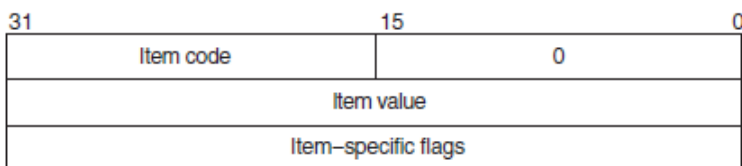

ZK-0949A-GE

The following diagram depicts the format of a 64-bit item descriptor that passes the selection criterion as a value.

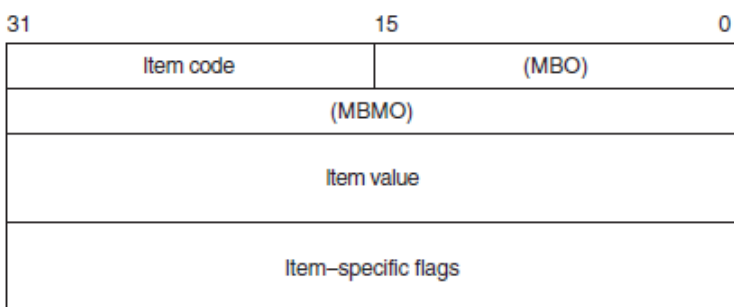

ZK-8924A-GE

The following diagram depicts the format of a 32-bit item descriptor that passes the selection criterion by reference.

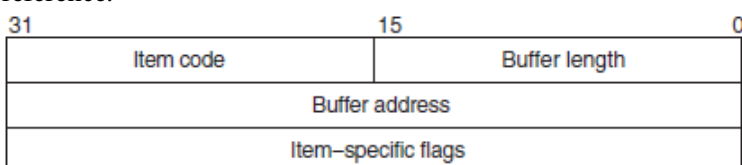

ZK-0948A-GE

The following diagram depicts the format of a 64-bit item descriptor that passes the selection criterion by reference.

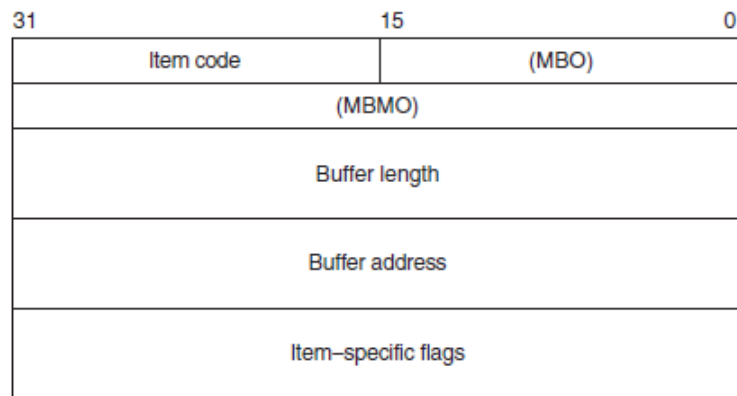

ZK-8925A-GE

The following table defines the item descriptor fields.

Descriptor Field	Definition
Buffer length	Buffer length is specified in a different way for the two types of item descriptors.
	Character string or reference descriptors: A word containing a user-supplied integer specifying the length (in bytes) of the buffer from which \$PROCESS_SCAN retrieves a selection criterion. The length of the buffer needed depends on the item code specified in the item descriptor.
	Immediate value descriptors: The length of the buffer is always specified as 0.
Item code	A word containing the selection criterion. These codes are defined by the \$PSCANDEF macro. Each item code is described after this list of descriptor fields.
Item value	A longword containing the actual value of the selection criterion. When you specify an item code that is passed by value, \$PROCESS_SCAN searches for the actual value contained in the item list. See the description of the buffer address field for information about item codes that are passed by reference.
Buffer address	A longword containing the user-supplied address of the buffer from which \$PROCESS_SCAN retrieves information needed by the scan. When you specify an item code that is passed by reference, \$PROCESS_SCAN uses the address as a pointer to the actual value. See the description of the item value field for information about item codes that are passed by value.
Item-specific flags	A longword that contains flags to help control selection information. Item-specific flags, for example EQL or NEQ, are used to specify how the value specified in the item descriptor is compared to the process value. These flags are defined by the \$PSCANDEF macro. Some flags are common to multiple item codes; other flags are specific to an individual item code. See the description of each item code to determine which flags are used. For item codes that describe bit masks or character strings, these flags control how the bit mask or character string is compared with that in the process. By default, they are compared for equality.

Descriptor Field	Definition
	For item codes that describe integers, these flags specify an arithmetic comparison of an integer item with the process attribute. For example, a PSCAN\$M_GTR selection specifying the value 4 for the item code PSCAN\$_PRIB finds only the processes with a base priority above 4. Without one of these flags, the comparison is for equality.
MBO	Must be 1.
MBMO	Must be -1.

Item Codes

PSCAN\$_ACCOUNT

When you specify PSCAN\$_ACCOUNT, \$GETJPI returns information about processes that match the account field.

If the string supplied in the item descriptor is shorter than the account field, the string is blank-padded for the comparison unless the item-specific flag PSCAN\$M_PREFIX_MATCH is present.

Because the information is a character string, the selection value is passed by reference. The length of the buffer is placed in the first word of the item descriptor and the address of the buffer is placed in the second longword.

Although the current length of the account field is 8 bytes, the PSCAN\$_ACCOUNT buffer can be up to 64 bytes in length. If the buffer length is 0 or greater than 64, the SS\$_IVBUFLN error is returned.

PSCAN\$_AUTHPRI

When you specify PSCAN\$_AUTHPRI, \$GETJPI returns information about processes that match the authorized base priority field.

This integer item code is passed by value; the value is placed in the second longword of the item descriptor. The buffer length must be specified as 0.

The flags that can be used with this item code are listed in Table 5.

PSCAN\$_CURPRIV

When you specify PSCAN\$_CURPRIV, \$GETJPI returns information about processes that match the current privilege field. Privilege bits are defined by the \$PRVDEF macro.

Because the bit mask information is too long to be passed by value, the information is passed by reference. The privilege buffer must be exactly 8 bytes, otherwise the SS\$_IVBUFLN error is returned.

The flags that can be used with this item code are listed in Table 5.

PSCAN\$_GETJPI_BUFFER_SIZE

When you specify PSCAN\$_GETJPI_BUFFER_SIZE, you determine the size of a buffer to be used by \$GETJPI to process multiple requests in a single message. Using this item code can greatly improve the performance of scans on remote nodes, because fewer messages are needed. This item code is ignored during scans on the local node.

This integer item code is passed by value; the value is placed in the second longword of the item descriptor. The buffer length must be specified as 0. The buffer is allocated by \$PROCESS_SCAN; you do not have to allocate a buffer.

If you use PSCAN\$_GETJPI_BUFFER_SIZE with \$PROCESS_SCAN, all calls to \$GETJPI using the context established by \$PROCESS_SCAN must request the same item code information. Because \$GETJPI locates information for more than one process at a time, it is not possible to change the item codes or the length of the buffers used in the \$GETJPI item list. \$GETJPI checks each call and returns the error SS\$_BADPARAM if an attempt is made to change the item list during a buffered process scan. However, the buffer addresses can be changed between \$GETJPI calls.

Because the locating and buffering of information by \$GETJPI is transparent to a calling program, you are not required to change the way \$GETJPI is called when you use this item code.

The \$GETJPI buffer uses the process quota BYTLM. If the buffer is too large for the process quota, \$GETJPI (not \$PROCESS_SCAN) returns the error SS\$_EXBYTLM. If the buffer specified is not large enough to contain the data for at least one process, \$GETJPI returns the error SS\$_BADPARAM.

No item-specific flags are used with PSCAN\$_GETJPI_BUFFER_SIZE.

PSCAN\$_GRP

When you specify PSCAN\$_GRP, \$GETJPI returns information about processes that match the UIC group number.

This integer item code is passed by value; the value is placed in the second longword of the item descriptor. Because the value of the group number is a word, the high-order word of the value is ignored. The buffer length must be specified as 0.

The flags that can be used with this item code are listed in Table 5.

PSCAN\$_HW_MODEL

When you specify PSCAN\$_HW_MODEL, \$GETJPI returns information about processes that match the specified CPU hardware model number.

The hardware model number is an integer, such as VAX\$K_V8840. The VAX\$ symbols are defined by the \$VAXDEF macro.

This integer item code is passed by value; the value is placed in the second longword of the item descriptor. The buffer length must be specified as 0.

The flags that can be used with this item code are listed in Table 5.

PSCAN\$_HW_NAME

When you specify PSCAN\$_HW_NAME, \$GETJPI returns information about processes that match the specified CPU hardware name, such as VAX-11/780, VAX 8800, or VAXstation II/GPX.

Because the information is a character string, the selection value is passed by reference. The length of the selection value is placed in the first word of the item descriptor and the address of the buffer is placed in the second longword.

The PSCAN\$_HW_NAME buffer can be up to 128 bytes in length. If the buffer length is 0 or greater than 128, the SS\$_IVBUFLN error is returned.

The flags that can be used with this item code are listed in Table 5.

PSCAN\$_JOBPRCNT

When you specify PSCAN\$_JOBPRCNT, \$GETJPI returns information about processes that match the subprocess count for the job (the count of all subprocesses in the job tree).

This integer item code is passed by value; the value is placed in the second longword of the item descriptor. The buffer length must be specified as 0.

The flags that can be used with this item code are listed in Table 5.

PSCAN\$_JOBTYPE

When you specify PSCAN\$_JOBTYPE, \$GETJPI returns information about processes that match the job type. The job type values include the following.

Value	Description
JPI\$K_LOCAL	Local interactive process
JPI\$K_DIALUP	Interactive process accessed by a modem line
JPI\$K_REMOTE	Interactive process accessed by using SET HOST
JPI\$K_BATCH	Batch process
JPI\$K_NETWORK	Noninteractive network process
JPI\$K_DETACHED	Detached process

These values are defined by the \$JPIDEF macro. Note that values checked by PSCAN\$_JOBTYPE are similar to PSCAN\$_MODE values.

This integer item code is passed by value; the value is placed in the second longword of the item descriptor. The buffer length must be specified as 0.

The flags that can be used with this item code are listed in Table 5.

PSCAN\$_KT_COUNT

When you specify PSCAN\$_KT_COUNT, \$PROCESS_SCAN uses the current count of kernel threads for the process as a selection criteria. The flags that can be used with this item code are listed in Table 5

PSCAN\$_MASTER_PID

When you specify PSCAN\$_MASTER_PID, \$GETJPI returns information about processes that are descendants of the specified parent process. The master process is the first process created in the job tree. The PSCAN\$_OWNER item is similar, but the owner process is the process that created the target process (the owner process might itself be a subprocess). Although all jobs in a job tree must have the same master, they can have different owners.

This integer item code is passed by value; the value is placed in the second longword of the item descriptor. The buffer length must be specified as 0.

The flags that can be used with this item code are listed in Table 5.

PSCAN\$_MEM

When you specify PSCAN\$_MEM, \$GETJPI returns information about processes that match the UIC member number.

This integer item code is passed by value; the value is placed in the second longword of the item descriptor. Because the value of the member number is a word, the high-order word of the value is ignored. The buffer length must be specified as 0.

The flags that can be used with this item code are listed in Table 5.

PSCAN\$_MODE

When you specify PSCAN\$_MODE, \$GETJPI returns information about processes that match the specified mode. Mode values include the following.

Value	Description
JPI\$K_INTERACTIVE	Interactive process
JPI\$K_BATCH	Batch job
JPI\$K_NETWORK	Noninteractive network job
JPI\$K_OTHER	Detached and other process

These values are defined by the \$JPIDEF macro. Note that values checked by PSCAN\$_MODE are similar to PSCAN\$_JOBTYPE values.

This integer item code is passed by value; the value is placed in the second longword of the item descriptor. The buffer length must be specified as 0.

The flags that can be used with this item code are listed in Table 5.

PSCAN\$_MULTITHREAD

When you specify PSCAN\$_MULTITHREAD, \$PROCESS_SCAN uses the maximum count of kernel threads for the process as a selection criteria. The flags that can be used with this item code are listed in Table 5.

PSCAN\$_NODE_CSID

When you specify PSCAN\$_NODE_CSID, \$GETJPI returns information about processes on the specified nodes. To scan all nodes in an OpenVMS Cluster system, you specify a CSID of 0 and the item-specific flag PSCAN\$_M_NEQ.

This integer item code is passed by value; the value is placed in the second longword of the item descriptor. The buffer length must be specified as 0.

The flags that can be used with this item code are listed in Table 5.

PSCAN\$_NODENAME

When you specify PSCAN\$_NODENAME, \$GETJPI returns information about processes that match the specified node names.

To scan all of the nodes in an OpenVMS Cluster system, specify the node name using an asterisk wildcard (*) and the PSCAN\$_M_WILDCARD item-specific flag.

Because the information is a character string, the selection value is passed by reference. The length of the selection value is placed in the first word of the item descriptor and the address of the buffer is placed in the second longword.

Although the current length of the node name is 6 bytes, the `PSCAN$_NODENAME` buffer can be up to 64 bytes in length. If the buffer length is 0 or greater than 64, the `SS$_IVBUFLLEN` error is returned.

The flags that can be used with this item code are listed in Table 5.

PSCAN\$_OWNER

When you specify `PSCAN$_OWNER`, `$GETJPI` returns information about processes that are immediate descendants of the specified process. The `PSCAN$_MASTER_PID` item is similar, but the owner process is the process that created the target process (the owner process might itself be a subprocess). Although all jobs in a job tree must have the same master, they can have different owners.

This integer item code is passed by value; the value is placed in the second longword of the item descriptor. The buffer length must be specified as 0.

The flags that can be used with this item code are listed in Table 5.

PSCAN\$_PRCCNT

When you specify `PSCAN$_PRCCNT`, `$GETJPI` returns information about processes that match the subprocess count (the count of all immediate descendants of a given process). The `PSCAN$_JOBPRCCNT` item code is similar, except that `JOBPRCCNT` is the count of all subprocesses in a job.

This integer item code is passed by value; the value is placed in the second longword of the item descriptor. The buffer length must be specified as 0.

The flags that can be used with this item code are listed in Table 5.

PSCAN\$_PRCNAM

When you specify `PSCAN$_PRCNAM`, `$GETJPI` returns information about processes that match the specified process names.

The process name string is blank-padded for the comparison unless the item-specific flag `PSCAN$_M_PREFIX_MATCH` is present.

Because the information is a character string, the selection value is passed by reference. The length of the selection value is placed in the first word of the item descriptor and the address of the buffer is placed in the second longword.

Although the current length of the process name field is 15 bytes, the `PSCAN$_PRCNAM` buffer can be up to 64 bytes in length. If the buffer length is 0 or greater than 64, the `SS$_IVBUFLLEN` error is returned.

The flags that can be used with this item code are listed in Table 5.

PSCAN\$_PRI

When you specify `PSCAN$_PRI`, `$GETJPI` returns information about processes that match current priority. Note that the current priority of a process can be temporarily increased as a result of system events such as the completion of I/O.

This integer item code is passed by value; the value is placed in the second longword of the item descriptor. The buffer length must be specified as 0.

The flags that can be used with this item code are listed in Table 5.

PSCAN\$_PRIB

When you specify PSCAN\$_PRIB, \$GETJPI returns information about processes that match base priority.

This integer item code is passed by value; the value is placed in the second longword of the item descriptor. The buffer length must be specified as 0.

The flags that can be used with this item code are listed in Table 5.

PSCAN\$_STATE

When you specify PSCAN\$_STATE, \$GETJPI returns information about processes that match the specified process state. State values, for example SCH\$C_COM and SCH\$C_PFW, are defined by the \$STATEDEF macro.

This integer item code is passed by value; the value is placed in the second longword of the item descriptor. The buffer length must be specified as 0.

The flags that can be used with this item code are listed in Table 5.

PSCAN\$_STS

When you specify PSCAN\$_STS, \$GETJPI returns information that matches the current status mask. Without any item-specific flags, the match is for a process mask that is equal to the pattern. Status bits, for example PCB\$V_ASTPEN or PCB\$V_PSWAPM, are defined by the \$PCBDEF macro.

This bit mask item code uses an immediate value descriptor; the selection value is placed in the second longword of the item descriptor. The buffer length must be specified as 0.

The flags that can be used with this item code are listed in Table 5.

PSCAN\$_TERMINAL

When you specify PSCAN\$_TERMINAL, \$GETJPI returns information that matches the specified terminal names. The terminal name string is blank-padded for the comparison unless the item-specific flag PSCAN\$M_PREFIX_MATCH is present.

Because the information is a character string, the selection value is passed by reference. The length of the selection value is placed in the first word of the item descriptor and the address of the buffer is placed in the second longword.

Although the current length of the terminal name field is 8 bytes, the PSCAN\$_TERMINAL buffer can be up to 64 bytes in length. If the buffer length is 0 or greater than 64, the SS\$_IVBUFLLEN error is returned.

The flags that can be used with this item code are listed in Table 5.

PSCAN\$_UIC

When you specify PSCAN\$_UIC, \$GETJPI returns information about processes that match the UIC identifier. To convert an alphanumeric identifier name to the internal identifier, use the \$ASCTOID system service before calling \$PROCESS_SCAN.

This integer item code is passed by value; the value is placed in the second longword of the item descriptor. The buffer length must be specified as 0.

The flags that can be used with this item code are listed in Table 5.

PSCAN\$_USERNAME

When you specify PSCAN\$_USERNAME, \$GETJPI returns information about processes that match the specified user name.

The user name string is blank-padded for the comparison unless the item-specific flag PSCAN\$_M_PREFIX_MATCH is present.

Because the information is a character string, the selection value is passed by reference. The length of the selection value is placed in the first word of the item descriptor and the address of the buffer is placed in the second longword.

Although the current length of the user name field is 12 bytes, the PSCAN\$_USERNAME buffer can be up to 64 bytes in length. If the buffer length is 0 or greater than 64, the SS\$_IVBUFLLEN error is returned.

The flags that can be used with this item code are listed in Table 5.

Item-Specific Flags

Table 5 lists the flags and the item codes that can be used together. The flags are described in the section following the table.

Table 5. Flags Used with \$PROCESS_SCAN

Item-Specific Flag	Description	Common to the Following \$PROCESS_SCAN Item Codes
PSCAN\$_M_BIT_ALL	All bits set in pattern set in target	_CURPRIV
PSCAN\$_M_BIT_ANY	Any bit set in pattern set in target	_STS
PSCAN\$_M_CASE_BLIND	Match without regard to case of letters	_ACCOUNT
PSCAN\$_M_EQL	Match value exactly (the default)	All except _BUFFER_SIZE
PSCAN\$_M_GEQ	Match if value is greater than or equal to	_AUTHPRI
PSCAN\$_M_GTR	Match if value is greater than	_GRP
PSCAN\$_M_LEQ	Match if value is less than or equal to	_JOBPRCNT
PSCAN\$_M_LSS	Match if value is less than	_PRI
		_PRIB
PSCAN\$_M_NEQ	Match if value is not equal	All except _BUFFER_SIZE
PSCAN\$_M_OR	Match this value or the next value	All except _BUFFER_SIZE
PSCAN\$_M_PREFIX_MATCH	Match on leading substring	_HW_NAME
PSCAN\$_M_WILDCARD	Match a wildcard pattern	_NODENAME _PRCNAM _TERMINAL _USERNAME

PSCAN\$_M_BIT_ALL

If the `PSCAN$M_BIT_ALL` flag is used, all bits set in the pattern mask specified by the item descriptor must also be set in the process mask. Other bits in the process mask can also be set.

For item codes that describe bit masks, such as privilege masks and status words, this flag controls how the pattern bit mask specified by the item descriptor is compared with that in the process. By default, the bit masks are compared for equality.

The `PSCAN$M_BIT_ALL` flag is used only with bit masks.

PSCAN\$M_BIT_ANY

If the `PSCAN$M_BIT_ANY` flag is used, a match occurs if any bit in the pattern mask is also set in the process mask.

For item codes that describe bit masks, such as privilege masks and status words, this flag controls how the pattern bit mask specified by the item descriptor is compared with that in the process. By default, the bit masks are compared for equality.

The `PSCAN$M_BIT_ANY` flag is used only with bit masks.

PSCAN\$M_CASE_BLIND

When you specify `PSCAN$M_CASE_BLIND` to compare the character string specified by the item descriptor with the character string value from the process, `$PROCESS_SCAN` does not distinguish between uppercase and lowercase letters.

The `PSCAN$M_CASE_BLIND` flag is used only with character-string item codes. The `PSCAN$M_CASE_BLIND` flag can be specified with either the `PSCAN$M_PREFIX_MATCH` flag or the `PSCAN$M_WILDCARD` flag.

PSCAN\$M_EQL

When you specify `PSCAN$M_EQL`, `$PROCESS_SCAN` compares the value specified by the item descriptor with the value from the process to see if there is an exact match.

`PSCAN$M_EQL` and `PSCAN$M_NEQ` are used with bit masks, character strings, and integers to control how the item is interpreted. Only one of the flags can be specified; if more than one of these flags is used, the `SS$_BADPARAM` error is returned. If you want to specify that bits not set in the pattern mask must not be set in the process mask, use `PSCAN$M_EQL`.

PSCAN\$M_GEQ

When you specify `PSCAN$M_GEQ`, `$PROCESS_SCAN` selects a process if the value from the process is greater than or equal to the value specified by the item descriptor.

`PSCAN$M_GEQ`, `PSCAN$M_GTR`, `PSCAN$M_LEQ`, and `PSCAN$M_LSS` are used with integer item codes only. Only one of these four flags can be specified; if more than one of these flags is used, the `SS$_BADPARAM` error is returned.

PSCAN\$M_GTR

When you specify `PSCAN$M_GTR`, `$PROCESS_SCAN` selects a process if the value from the process is greater than the value specified by the item descriptor.

`PSCAN$M_GEQ`, `PSCAN$M_GTR`, `PSCAN$M_LEQ`, and `PSCAN$M_LSS` are used with integer item codes only. Only one of these four flags can be specified; if more than one of these flags is used, the `SS$_BADPARAM` error is returned.

PSCAN\$M_LEQ

When you specify PSCAN\$M_LEQ, \$PROCESS_SCAN selects a process if the value from the process is less than or equal to the value specified by the item descriptor.

PSCAN\$M_GEQ, PSCAN\$M_GTR, PSCAN\$M_LEQ, and PSCAN\$M_LSS are used with integer item codes only. Only one of these four flags can be specified; if more than one of these flags is used, the SSS_BADPARAM error is returned.

PSCAN\$M_LSS

When you specify PSCAN\$M_LSS, \$PROCESS_SCAN selects a process if the value from the process is less than the value specified by the item descriptor.

PSCAN\$M_GEQ, PSCAN\$M_GTR, PSCAN\$M_LEQ, and PSCAN\$M_LSS are used with integer item codes only. Only one of these four flags can be specified; if more than one of these flags is used, the SSS_BADPARAM error is returned.

PSCAN\$M_NEQ

When you specify PSCAN\$M_NEQ, \$PROCESS_SCAN selects a process if the value from the process is not equal to the value specified by the item descriptor.

PSCAN\$M_EQL and PSCAN\$M_NEQ are used with bit masks, character strings, and integers to control how the item is interpreted. Only one of the flags can be specified; if more than one of these flags is used, the SSS_BADPARAM error is returned.

PSCAN\$M_OR

When you specify PSCAN\$M_OR, \$PROCESS_SCAN selects processes whose values match the current item descriptor or the next item descriptor. The next item descriptor must have the same item code as the item descriptor with the PSCAN\$M_OR flag. Multiple items are chained together; all except the last item descriptor must have the PSCAN\$M_OR flag.

The PSCAN\$M_OR flag can be specified with any other flag and can be used with bit masks, character strings, and integers. If the PSCAN\$M_OR flag is used between different item codes, or if it is missing between identical item codes, the SSS_BADPARAM error is returned.

PSCAN\$M_PREFIX_MATCH

When you specify PSCAN\$M_PREFIX_MATCH, \$PROCESS_SCAN compares the character string specified in the item descriptor to the leading characters of the requested process value.

For example, to find all process names that start with the letters *AB*, use the string *AB* with the PSCAN\$M_PREFIX_MATCH flag. If you do not specify the PSCAN\$M_PREFIX_MATCH flag, the search looks for a process with the 2-character process name *AB*.

The PSCAN\$M_PREFIX_MATCH flag also allows either the PSCAN\$M_EQL or the PSCAN\$M_NEQ flag to be specified. If you specify PSCAN\$M_NEQ, the service matches those names that do *not* begin with the specified character string.

The PSCAN\$M_PREFIX_MATCH flag is used only with character string item codes. The PSCAN\$M_PREFIX_MATCH flag cannot be specified with the PSCAN\$M_WILDCARD flag; if both of these flags are used, the SSS_BADPARAM error is returned.

PSCAN\$M_WILDCARD

When you specify `PSCAN$M_WILDCARD`, the character string specified by the item descriptor is assumed to be a wildcard pattern. Acceptable wildcard characters are the asterisk (*), which allows the match to substitute any number of character in place of the asterisk, and the percent sign (%), which allows the match to substitute any one character in place of the percent sign. For example, if you want to search for all process names that begin with the letter *A* and end with the string *ER*, use the string *A*ER* with the `PSCAN$M_WILDCARD` flag. If the `PSCAN$M_WILDCARD` flag is not specified, the search looks for the 4-character process name *A*ER*.

The following restrictions apply to the flags above:

- Only one of the flags `PSCAN$M_EQL`, `PSCAN$M_NEQ`, `PSCAN$M_BIT_ALL`, `PSCAN$M_BIT_ANY` can be specified
- `PSCAN$M_CASE_BLIND` item-specific flag also allows either the `PSCAN$M_EQL` or the `PSCAN$M_NEQ` flag to be specified
- Only one of the flags `PSCAN$M_EQL` and `PSCAN$M_WILD_CARD` can be specified

Description

The Process Scan system service creates and initializes a process context that is used by `$GETJPI` to scan processes on the local system or across the nodes in an OpenVMS Cluster system. An item list is used to specify selection criteria to obtain information about specific processes, for example, all processes owned by one user or all batch processes.

The output of the `$PROCESS_SCAN` service is a process context longword named *pidctx*. This process context is then provided to `$GETJPI` as the *pidadr* argument. The process context provided by `$PROCESS_SCAN` enables `$GETJPI` to search for processes across the nodes in an OpenVMS Cluster system and to select processes that match certain selection criteria.

The process context consumes process dynamic memory. This memory is deallocated when the end of the context is reached. For example, when the `$GETJPI` service returns `SS$_NOMOREPROC` or when `$PROCESS_SCAN` is called again with the same *pidctx* longword, the dynamic memory is deallocated. If you anticipate that a scan might be interrupted before it runs out of processes, `$PROCESS_SCAN` should be called a second time (without an *itmlst* argument) to release the memory. Dynamic memory is automatically released when the current image terminates.

`$PROCESS_SCAN` copies the item list and user buffers to the allocated dynamic memory. This means that the item lists and user buffers can be deallocated or reused immediately; they are not referenced during the calls to `$GETJPI`.

The item codes referenced by `$PROCESS_SCAN` are found in data structures that are always resident in the system, primarily the process control block (PCB) and the job information block (JIB). A scan of processes never forces a process that is swapped out of memory to be brought into memory to read nonresident information.

See the `$GETJPI` service for a C program example that uses the `$PROCESS_SCAN` service.

Required Access or Privileges

None

Required Quota

See the description for the `PSCAN$_GETJPI_BUFFER_SIZE` item.

Related Services

\$SCANEXH, \$SCREPRC, \$SDCLEXH, \$DELPRC, \$EXIT, \$FORCEX, \$GETJPI, \$GETJPIW, \$HIBER, \$RESUME, \$SETPRI, \$SETPRN, \$SETPRV, \$SETRWM, \$SUSPND, \$WAKE

Condition Values Returned

SS\$_NORMAL

The service completed successfully.

SS\$_ACCVIO

The *pidctx* argument cannot be written by the caller; the item list cannot be read by the caller; or a buffer for a reference descriptor cannot be read.

SS\$_BADPARAM

The item list contains an invalid item identifier, or an invalid combination of item-specific flags is present. Or, an item list containing both 32-bit and 64-bit item list entries was found.

SS\$_IVBUFLEN

The buffer length field is invalid. For immediate value descriptors, the buffer length must be 0. For reference descriptors, the buffer length cannot be 0 or longer than the maximum for the specified item code. This error is also returned if the total length of the item list plus the length of all of the buffer fields is too large to process.

SS\$_IVSSRQ

The *pidctx* argument was not supplied, or the item list is improperly formed (for example, multiple occurrences of a given item code were interspersed with other item codes).

\$PURGWS

Purge Working Set — Removes a specified range of pages from the current working set of the calling process to make room for pages required by a new program segment.

Format

```
SYS$PURGWS inadr
```

C Prototype

```
int sys$purgws (struct _va_range *inadr);
```

Argument

inadr

OpenVMS usage: address_range

type: longword (unsigned)
access: read only
mechanism: by reference

Starting and ending virtual addresses of the range of pages to be purged. The *inadr* argument is the address of a 2-longword array containing, in order, the starting and ending process virtual addresses. The addresses are adjusted up or down to fall on CPU-specific page boundaries. Only the virtual page number portion of each virtual address is used; the low-order byte-within-page bits are ignored.

Description

The Purge Working Set service removes a specified range of pages from the current working set of the calling process to make room for pages required by a new program segment; however, the Adjust Working Set Limit (\$ADJWSL) service is the preferred mechanism for controlling a process's use of physical memory resources.

The \$PURGWS service locates pages within the specified range and removes them if they are in the working set.

If the starting and ending virtual addresses are the same, only that single page is purged.

To purge the entire working set, specify a range of pages from 0 through 7FFFFFFF; in this case, the image continues to execute and pages are faulted back into the working set as they are needed. If you exceed this range, the service returns SS\$_NOPRIV. On Alpha and Integrity server systems, use the \$PURGE_WS service to specify a larger page range.

Required Access or Privileges

None

Required Quota

None

Related Services

\$ADJSTK, \$ADJWSL, \$CRETVA, \$CRMPSC, \$DELTVA, \$DGBLSC, \$EXPREG, \$LCKPAG, \$LKWSET, \$MGBLSC, \$PURGE_WS, \$SETPRT, \$SETSTK, \$SETSWM, \$ULKPAG, \$ULWSET, \$UPDSEC, \$UPDSECW

Condition Values Returned

SS\$_NORMAL

The service completed successfully.

SS\$_ACCVIO

The input address array cannot be read by the caller.

SS\$_NOPRIV

A page in the specified range is in the system address space.

\$PURGE_WS (Alpha and Integrity servers)

Purge Working Set — On Alpha and Integrity server systems, removes a specified range of pages from the current working set of the calling process to make room for pages required by a new program segment. This service accepts 64-bit addresses.

Format

```
SYS$PURGE_WS start_va_64 ,length_64
```

C Prototype

```
int sys$purge_ws (void *start_va_64, unsigned __int64 length_64);
```

Arguments

start_va_64

OpenVMS usage: address
type: quadword address
access: read only
mechanism: by value

The starting virtual address of the pages to be purged from the working set. The specified virtual address will be rounded down to a CPU-specific page boundary.

length_64

OpenVMS usage: byte count
type: quadword (unsigned)
access: read only
mechanism: by value

Length of the virtual address space to be purged from the working set. The specified length will be rounded up to a CPU-specific page boundary so that it includes all CPU-specific pages in the requested range.

Description

The Purge Working Set service removes a specified range of pages from the current working set of the calling process to make room for pages required by a new program segment. However, the Adjust Working Set Limit (\$ADJWSL) service is the preferred mechanism for controlling a process's use of physical memory resources.

The \$PURGE_WS service locates pages within the specified range and removes them if they are in the working set. To purge the entire working set, specify a range of pages from 0 through FFFFFFFF.FFFFFFFF (or to the highest possible process private virtual address, available from \$GETJPI); in this case, the image continues to execute, and pages are faulted back into the working set.

Required Privileges

None

Required Quota

None

Related Services

\$ADJWSL, \$LCKPAG_64, \$LKWSET_64, \$PURGWS, \$ULKPAG_64, \$ULWSET_64

Condition Values Returned

SS\$_NORMAL

The service completed successfully.

\$PUT

Inserts Record — The Put service inserts a record into a file.

For additional information about this service, see the *VSI OpenVMS Record Management Services Reference Manual*

\$PUTMSG

Put Message — Writes informational and error messages to processes. On Alpha and Integrity server systems, this service accepts 64-bit addresses. Note that the return value from **actrtn* is checked to determine whether or not the message is output.

Format

```
SYS$PUTMSG msgvec , [actrtn] , [facnam] , [actprm]
```

C Prototype

```
int sys$putmsg  
    (void *msgvec, void (*actrtn)(__unknown_params), void *facnam,  
     unsigned __int64 actprm);
```

Arguments

msgvec

OpenVMS usage: cntrlblk
type: longword (unsigned)
access: read only

mechanism: by 32- or 64-bit reference (Alpha and Integrity servers)

Message argument vector specifying the message or messages to be written and options that \$PUTMSG is to use in writing the message or messages. The *msgvec* argument is the 32- or 64-bit address (on Alpha and Integrity server systems) of the message vector.

The message vector consists of one longword followed by one or more message descriptors, one descriptor per message. The following diagram depicts the contents of the first longword:

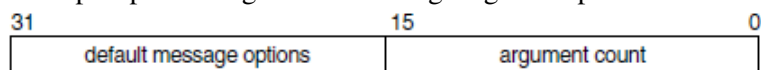

ZK-1717-GE

The following table describes the message vector fields.

Descriptor Field	Definition
Argument count	This word-length field specifies the total number of longwords in the message vector, not including the first longword (of which it is a part).
Default message options	This word-length field specifies which message component or components are to be written. The default message options field is a word-length bit vector wherein a bit, when set, specifies that the corresponding message component is to be written. For a description of each of these components, refer to the Description section.

The following table shows the significant bit numbers. Note that the bit numbers shown (0, 1, 2, 3) are the bit positions from the beginning of the word; however, because the word is the second word in the longword, you should add the number 16 to each bit number to specify its exact offset within the longword.

Bit	Value	Description
0	1	Include message text
	0	Do not include message text
1	1	Include mnemonic name for message text
	0	Do not include mnemonic name for message text
2	1	Include severity level indicator
	0	Do not include severity level indicator
3	1	Include facility prefix
	0	Do not include facility prefix

Bits 4 through 15 must be 0.

You can override the default setting specified by the default message options field for any or all messages by specifying different options in the new message options field of any subsequent message descriptor. When you specify new message options, the options it specifies become the new default settings for all remaining messages until you specify new message options again.

The \$PUTMSG service passes the default message options field to the \$GETMSG service as the *flags* argument.

If you specify the default message options field as 0, the default message options for the process are used; you can set the process default message options by using the DCL command SET MESSAGE.

The Description section shows the format that \$PUTMSG uses to write these message components.

Message Descriptors

Following the first longword of the message vector are one or more message descriptors. A message descriptor can have one of four possible formats, depending on the type of message it describes. There are four types of messages:

- User-supplied
- System
- OpenVMS RMS
- System exception

The following diagrams depict the message descriptors for each type of message.

Message Descriptor for User-Supplied Messages

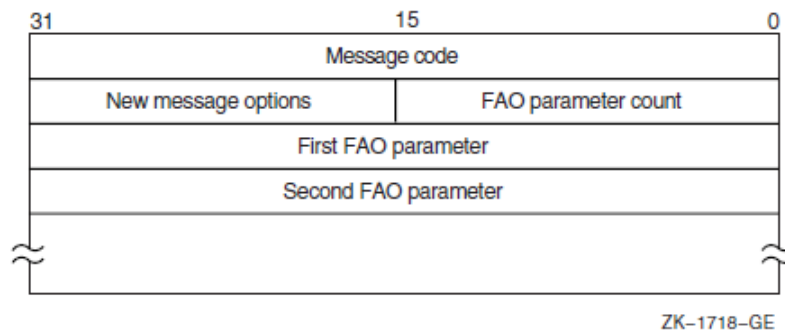

Message Descriptor Field	Definition
Message code	Longword value that uniquely identifies the message. The Description section discusses the message code; the <i>VSI OpenVMS Command Definition, Librarian, and Message Utilities Manual</i> explains how to create message codes.
FAO parameter count	Word-length value specifying the number of longword \$FAO parameters that follow in the message descriptor. The number of \$FAO parameters needed depends on the \$FAO directives used in the message text; some \$FAO directives require one or more parameters, while some directives require none.
New message options	Word-length bit vector specifying new message options for the current message. The contents and format of this field are identical to that of the default message options field.
FAO parameter	Longword value used by an \$FAO directive appearing in the message text. The \$FAO parameters listed in the message descriptor must appear in the order in which they will be used by the \$FAO directives in the message text.

Message Descriptor for System Messages

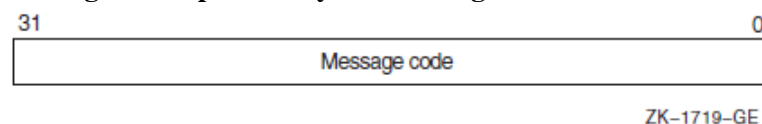

Message Descriptor Field	Definition
Message code	Longword value that uniquely identifies the message. The facility number field in the message code identifies the facility associated with the message. A system message has a facility number of 0. You cannot specify the FAO parameter count, new message options, and FAO parameter fields. Each longword following the message identification field in the message vector will be interpreted as another message identification.

Message Descriptor for OpenVMS RMS Messages

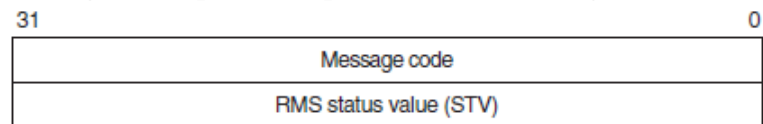

ZK-1720-GE

Message Descriptor Field	Definition
Message code	Longword value that uniquely identifies the message. The <i>facility number</i> field in the message code identifies the facility associated with the message. An OpenVMS RMS message has a facility number of 1. You cannot specify the FAO parameter count, new message options, and FAO parameter fields. The longword following the message identification field in the message vector will be interpreted as a standard value field (STV).
RMS status value	Longword containing an STV for use by an RMS message that has an associated STV value. The \$PUTMSG service uses the STV value as an \$FAO parameter or as another message identification, depending on the RMS message identified by the message identification field. If the RMS message does not have an associated STV, \$PUTMSG ignores the STV longword in the message descriptor.

Message Descriptor for System Exception Messages

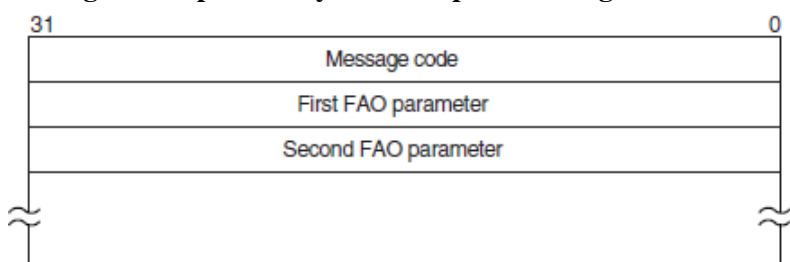

ZK-1721-GE

Message Descriptor Field	Definition
Message code	Longword value that uniquely identifies the message. The facility number field in the message code identifies the facility associated with the message. A system exception message has a facility number of 0. You cannot specify the FAO parameter count and new message options fields. The longword or longwords following the message code field in the message vector will be interpreted as \$FAO parameters.

On Alpha and Integrity server systems, 64-bit message vectors can be used for applications that require them. A 64-bit message vector begins with the same argument count longword as the 32-bit message vector. After the argument count longword is another longword containing the value `SS$_SIGNAL64`, which signals that a 64-bit message vector follows. Subsequent message vector elements have a layout analogous to 32-bit message vectors but are 64-bits wide.

For example, the following diagram depicts the format of a 32-bit message vector:

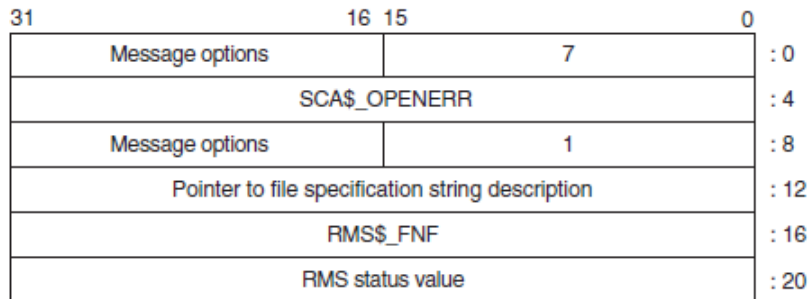

ZK-8549A-GE

The 64-bit version of that same message vector would have the following format:

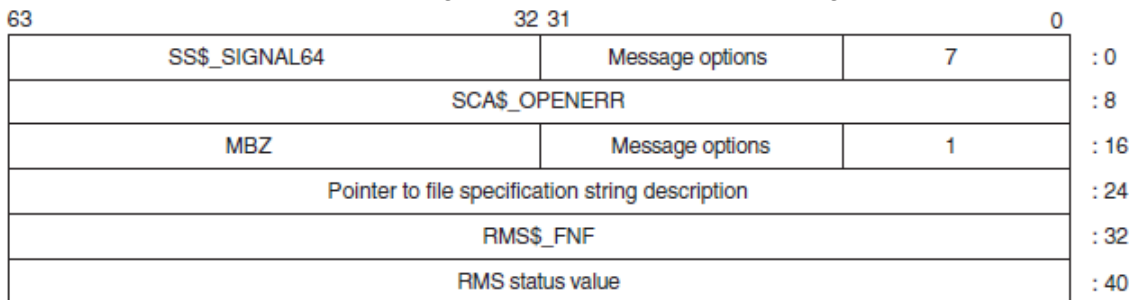

ZK-8550A-GE

The `$PUTMSG` service accepts either the 32-bit or the 64-bit form of the message vector on Alpha systems.

actrtn

OpenVMS usage: procedure
 type: procedure value
 access: call without stack unwinding
 mechanism: by 32- or 64-bit reference (Alpha and Integrity servers)

User-supplied action routine to be executed during message processing. The *actrtn* argument is the 32- or 64-bit address (on Alpha and Integrity server systems) of this routine.

Note that the first argument passed to the action routine is the address of a character string descriptor pointing to the message text; the parameter specified by *actprm* is the second.

The action routine receives control after a message is formatted but before it is actually written to the user.

The completion code in general register R0 from the action routine indicates whether the message should be written. If the low-order bit of R0 is set (1), then the message will be written. If the low-order bit is cleared (0), then the message will not be written.

If you do not specify *actrtn* or specify it as 0 (the default), no action routine executes.

Because \$PUTMSG writes messages only to SYSS\$ERROR and SYSS\$OUTPUT, an action routine is useful when output must be directed to, for example, a file.

facnam

OpenVMS usage: char_string
 type: character-coded text string
 access: read only
 mechanism: by 32- or 64-bit descriptor–fixed-length string descriptor (Alpha and Integrity servers)

Facility prefix to be used in the first or only message written by \$PUTMSG. The *facnam* argument is the 32- or 64-bit address (on Alpha and Integrity server systems) of a character string descriptor pointing to this facility prefix.

If you do not specify *facnam*, \$PUTMSG uses the default facility prefix associated with the message.

actprm

OpenVMS usage: user_arg
 type: longword (unsigned)
 access: read only
 mechanism: by value

Parameter to be passed to the action routine. The *actprm* argument is a longword value containing this parameter. If you do not specify *actprm*, no parameter is passed.

Description

In the operating system, a message is identified by a longword value, which is called the message code. To construct a message code, you specify values for its four fields, using the Message utility. The following diagram depicts the longword message code.

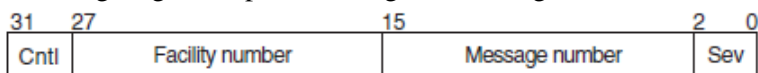

ZK-1722-GE

Thus, each message has a unique longword value associated with it: its message code. You can give this longword value a symbolic name using the Message utility. Such a symbolic name is called the message symbol.

The Message utility describes how to construct a message symbol according to the conventions for operating system messages. Basically, the message symbol has two parts: (1) a facility prefix, which is an abbreviation of the name of the facility with which the message is associated, and (2) a mnemonic name for the message text, which serves to hint at the nature of the message. These two parts are separated by an underscore character (_) in the case of a user-constructed message and by a dollar sign/underscore (\$_) in the case of system messages.

The message components written by \$PUTMSG are derived both from the message code and from the message symbol. For additional information about both the message code and the message symbol, refer to the *VSI OpenVMS Command Definition, Librarian, and Message Utilities Manual*.

The \$PUTMSG service writes the message components in the following format:

```
%FACILITY-L-IDENT, message text
```

where:

%	Is the prefix used for the first message written. The hyphen (-) is the prefix used for the remaining messages.
FACILITY	Is the facility prefix taken from the message symbol. This facility prefix can be overridden by a facility prefix specified in the <i>facnam</i> argument in the call to \$PUTMSG.
L	Is the severity level indicator. The severity level indicator is taken from the message code.
IDENT	Is a mnemonic name for the message text, taken from the message symbol.
message text	Is the message text specified in the message source file.

The \$PUTMSG service does not check the length of the argument list and therefore cannot return the `SS$_INSFARG` (insufficient arguments) condition value. Be sure you specify the required number of arguments.

If an error occurs while \$PUTMSG calls the Formatted ASCII Output (\$FAO) service, \$FAO parameters specified in the message vector do not appear in the output.

You cannot call the \$PUTMSG service from kernel mode.

Required Access or Privileges

None

Required Quota

None

Related Services

\$ALLOC, \$ASSIGN, \$BRKTHRU, \$BRKTHRUW, \$CANCEL, \$CREMBX, \$DALLOC, \$DASSGN, \$DELMBX, \$DEVICE_SCAN, \$DISMOU, \$GETDVI, \$GETDVIW, \$GETMSG, \$GETQUI, \$GETQUIW, \$INIT_VOL, \$MOUNT, \$QIO, \$QIOW, \$SNDERR, \$SNDJBC, \$SNDJBCW, \$SNDOPR

Condition Values Returned

`SS$_NORMAL`

The service completed successfully.

Example

```
#include <ssdef.h>
#include <rmsdef.h>
#include <starlet.h>
```

```
main()
{
    int msgvec[] = {3,                /* Arg count and message flags */
                   SS$_ABORT,        /* Message code */
                   RMS$_FNF,         /* RMS Message code */
                   0};               /* RMS Status value */

    return (sys$putmsg(msgvec));     /* Generate message */
}
```

\$QIO

Queue I/O Request — Queues an I/O request to a channel associated with a device. This service completes asynchronously; for synchronous completion, use the Queue I/O Request and Wait (\$QIOW) service. For additional information about system service completion, see the Synchronize (\$SYNCH) service. On Alpha and Integrity server systems, this service accepts 64-bit addresses.

Format

```
SYS$QIO
    [efn] ,chan ,func ,[iosb] ,[astadr] ,[astprm]
    ,[p1] ,[p2] ,[p3] ,[p4] ,[p5] ,[p6]
```

C Prototype

```
int sys$qio
(unsigned int efn, unsigned short int chan, unsigned int func,
 struct _iosb *iosb, void (*astadr)(__unknown_params),
 __int64 astprm, void *p1, __int64 p2, __int64 p3, __int64 p4,
 __int64 p5, __int64 p6);
```

Arguments

efn

OpenVMS usage: ef_number
type: longword (unsigned)
access: read only
mechanism: by value

Event flag that \$QIO is to set when the I/O operation completes. The *efn* argument is a longword value containing the number of the event flag; however, \$QIO uses only the low-order byte.

If you do not specify *efn*, event flag 0 is used.

When \$QIO begins execution, it clears the specified event flag or event flag 0 if *efn* was not specified.

The specified event flag is set if the service terminates without queuing an I/O request.

chan

OpenVMS usage: channel

type: word (unsigned)
 access: read only
 mechanism: by value

I/O channel assigned to the device to which the request is directed. The *chan* argument is a word value containing the number of the I/O channel; however, \$QIO uses only the low-order word.

Specifying an invalid value for the *chan* argument will result in either SS\$_IVCHAN or SS\$_IVIDENT being returned.

func

OpenVMS usage: function_code
 type: longword (unsigned)
 access: read only
 mechanism: by value

Device-specific function codes and function modifiers specifying the operation to be performed. The *func* argument is a longword containing the function code.

Each device has its own function codes and function modifiers. For complete information about the function codes and function modifiers that apply to the particular device to which the I/O operation is to be directed, refer to the *VSI OpenVMS I/O User's Reference Manual*.

iosb

OpenVMS usage: io_status_block
 type: quadword (unsigned)
 access: write only
 mechanism: by 32- or 64-bit reference (Alpha and Integrity servers)

I/O status block to receive the final completion status of the I/O operation. The *iosb* argument is the address of the quadword I/O status block. The following diagram depicts the structure of the I/O status block.

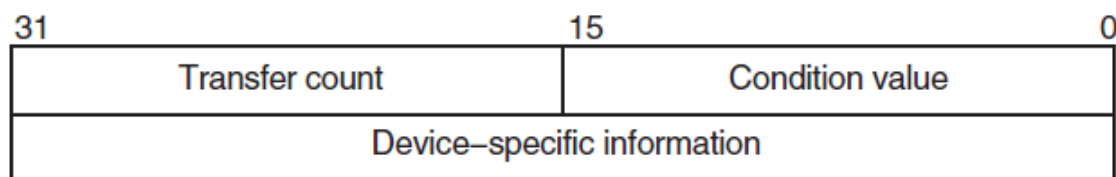

ZK-1723-GE

The following table defines the I/O status block fields.

Status Block Field	Definition
Condition value	Word-length condition value that \$QIO returns when the I/O operation actually completes.
Transfer count	Number of bytes of data transferred in the I/O operation. For information about how specific devices handle this field of the I/O status block, refer to the <i>VSI OpenVMS I/O User's Reference Manual</i> .

Status Block Field	Definition
Device-specific information	Contents of this field vary depending on the specific device and on the specified function code. For information on how specific devices handle this field of the I/O status block, refer to the <i>VSI OpenVMS I/O User's Reference Manual</i> .

When \$QIO begins execution, it clears the quadword I/O status block if the *iosb* argument is specified.

Though this argument is optional, VSI strongly recommends that you specify it, for the following reasons:

- If you are using an event flag to signal the completion of the service, you can test the I/O status block for a condition value to be sure that the event flag was not set by an event other than service completion.
- If you are using the \$SYNCH service to synchronize completion of the service, the I/O status block is a required argument for \$SYNCH.
- The condition value returned in R0 and the condition value returned in the I/O status block provide information about different aspects of the call to the \$QIO service. The condition value returned in R0 gives you information about the success or failure of the service call itself; the condition value returned in the I/O status block gives you information about the success or failure of the service operation. Therefore, to accurately assess the success or failure of the call to \$QIO, you must first check the condition value returned in R0. If R0 contains a successful value, then you must check the condition value in the I/O status block.

astadr

OpenVMS usage: `ast_procedure`
 type: `procedure value`
 access: `call without stack unwinding`
 mechanism: `by 32- or 64-bit reference (Alpha and Integrity servers)`

AST service routine to be executed when the I/O completes. The *astadr* argument is the address of the AST routine.

The AST routine executes at the access mode of the caller of \$QIO.

astprm

OpenVMS usage: `user_arg`
 type: `quadword unsigned (Alpha and Integrity servers)`
 access: `read only`
 mechanism: `by 64-bit value (Alpha and Integrity servers)`

AST parameter to be passed to the AST service routine. On Alpha and Integrity server systems, the *astprm* argument is a quadword value containing the AST parameter.

p1 to p6

OpenVMS usage: `varying_arg`
 type: `quadword (unsigned) (Alpha and Integrity servers)`
 access: `read only`

mechanism: by 32- or 64-bit reference or by 64-bit value, depending on the I/O function (Alpha and Integrity servers)

Optional device-specific and function-specific I/O request parameters. For example, the *p1* parameter usually specifies a buffer by reference. Other parameters, such as the buffer size, disk block number, or carriage control are often passed by value.

For more information about these parameters, see the *VSI OpenVMS I/O User's Reference Manual*.

Description

The Queue I/O Request service operates only on assigned I/O channels and only from access modes that are equal to or more privileged than the access mode from which the original channel assignment was made.

The \$QIO service uses system dynamic memory to construct a database to queue the I/O request and might require additional memory depending on the queued device.

For \$QIO, you can synchronize completion (1) by specifying the *astadr* argument to have an AST routine execute when the I/O completes or (2) by calling the Synchronize (\$SYNCH) service to await completion of the I/O operation. The \$QIOW service completes synchronously, and it is the best choice when synchronous completion is required.

For information about how to use the \$QIO service for network operations, refer to the *VSI OpenVMS DECnet Networking Manual*.

Required Access or Privileges

LOG_IO or PHY_IO is required, depending upon the device type and the requested operation. DIAGNOSE is required to issue a \$QIO with an associated diagnostic buffer. In addition, read or write access is generally required for the device. For more information, see the *VSI OpenVMS Guide to System Security*.

Required Quota

The \$QIO service uses the following quotas:

- The process's quota for buffered I/O limit (BIOLM) or direct I/O limit (DIOLM)
- The process's buffered I/O byte count (BYTLM) quota
- The process's AST limit (ASTLM) quota, if an AST service routine is specified

Related Services

\$ALLOC, \$ASSIGN, \$BRKTHRU, \$BRKTHRUW, \$CANCEL, \$CREMBX, \$DALLOC, \$DASSGN, \$DELMBOX, \$DEVICE_SCAN, \$DISMOU, \$GETDVI, \$GETDVIW, \$GETMSG, \$GETQUI, \$GETQUIW, \$INIT_VOL, \$MOUNT, \$PUTMSG, \$QIOW, \$SENDERR, \$SENDJBC, \$SENDJBCW, \$SENDOPR, \$IO_CLEANUP, \$IO_PERFORM, \$IO_SETUP

Condition Values Returned

SS\$_NORMAL

The service completed successfully. The I/O request was successfully queued.

SS\$_ABORT

A network logical link was broken.

SS\$_ACCVIO

Either the I/O status block cannot be written by the caller, or the parameters for device-dependent function codes are specified incorrectly.

SS\$_CONNECFAIL

The connection to a network object timed out or failed.

SS\$_DEVOFFLINE

The specified device is off line and not currently available for use.

SS\$_EXQUOTA

The process has (1) exceeded its AST limit (ASTLM) quota, (2) exceeded its buffered I/O byte count (BYTLM) quota, (3) exceeded its buffered I/O limit (BIOLM) quota, (4) exceeded its direct I/O limit (DIOLM) quota, or (5) requested a buffered I/O transfer smaller than the buffered byte count quota limit (BYTLM), but when added to other current buffer requests, the buffered I/O byte count quota was exceeded.

SS\$_FILALRACC

A logical link is already accessed on the channel (that is, a previous connect on the channel).

SS\$_FILEFULL

File full; allocation failure. An attempt to extend a file will exceed the maximum supported size of the file. For ODS-2 and ODS-5 disks, this is 2 TB (4,294,967,295 blocks). Reduce the size of the extend request. If the difference between the maximum file size and the current file is less than the cluster size, the file cannot be extended.

SS\$_ILLEFC

You specified an illegal event flag number.

SS\$_INSFMEM

The system dynamic memory is insufficient for completing the service.

SS\$_INVLOGIN

The access control information was invalid at the remote node.

SS\$_IVCHAN

You specified an invalid channel number, that is, a channel number of 0, or you failed to specify a channel number.

SS\$_IIDENT

You specified a channel number greater than the number of channels assigned for the process.

SS\$_IVDEVNAM

The NCB has an invalid format or content.

SS\$_LINKABORT

The network partner task aborted the logical link.

SS\$_LINKDISCON

The network partner task disconnected the logical link.

SS\$_LINKEXIT

The network partner task was started, but exited before confirming the logical link (that is, \$ASSIGN to SYS\$NET).

SS\$_NOLINKS

No logical links are available. The maximum number of logical links as set for the executor MAXIMUM LINKS parameter was exceeded.

SS\$_NOPRIV

The specified channel does not exist or was assigned from a more privileged access mode, or the process does not have the necessary privileges to perform the specified functions on the device associated with the specified channel.

SS\$_NOSUCHNODE

The specified node is unknown.

SS\$_NOSUCHOBJ

The network object number is unknown at the remote node; or for a TASK= connect, the named DCL command procedure file cannot be found at the remote node.

SS\$_NOSUCHUSER

The remote node could not recognize the login information supplied with the connection request.

SS\$_NOT64DEVFUNC

On Alpha and Integrity server systems, this fatal condition value is returned under the following circumstances: (1) The caller has specified a 64-bit virtual address in the P1 device dependent parameter but the device driver does not support 64-bit addresses with the requested I/O function. (2) The caller has specified a 64-bit address for a diagnostic buffer but the device driver does not support 64-bit addresses for diagnostic buffers. (3) Some device drivers might also return this condition value when 64-bit buffer addresses are passed using the P2 through P6 parameters and the driver does not support a 64-bit address with the requested I/O function.

SS\$_PATHLOST

The path to the network partner task node was lost.

SS\$_PROTOCOL

A network protocol error occurred. This error is most likely due to a network software error.

SS\$_REJECT

The network object rejected the connection.

SS\$_REMRSRC

The link could not be established because system resources at the remote node were insufficient.

SS\$_SHUT

The local or remote node is no longer accepting connections.

SS\$_THIRDPARTY

The logical link was terminated by a third party (for example, the system manager).

SS\$_TOOMUCHDATA

The task specified too much optional or interrupt data.

SS\$_UNASEFC

The process is not associated with the cluster containing the specified event flag.

SS\$_UNREACHABLE

The remote node is currently unreachable.

SS\$_UNSUPPORTED

Unsupported operation or function. An attempt has been made to create a contiguous file with a size greater than the supported maximum. For ODS-2 and ODS-5 disks, this value is 1,073,741,824 blocks. Reduce the size of the request when creating such a file.

Condition Values Returned in the I/O Status Block

Device-specific condition values; the *VSI OpenVMS I/O User's Reference Manual* lists these condition values for each device.

\$QIOW

Queue I/O Request and Wait — The Queue I/O Request and Wait service queues an I/O request to a channel associated with a device.

Format

```
SY$QIOW
    [efn] ,chan ,func , [iosb] , [astadr] , [astprm]
    , [p1] , [p2] , [p3] , [p4] , [p5] , [p6]
```

C Prototype

```
int sys$qiow
    (unsigned int efn, unsigned short int chan, unsigned int func,
```



```
struct _iosb *iosb, void (*astadr)(__unknown_params),
__int64 astprm, void *p1, __int64 p2, __int64 p3,
__int64 p4, __int64 p5, __int64 p6);
```

Description

The \$QIOW service completes synchronously; however, VSI recommends that you use an IOSB with this service to avoid premature completion.

For asynchronous completion, use the Queue I/O Request (\$QIO) service.

In all other respects, \$QIOW is identical to \$QIO. For more information about \$QIOW, refer to the description of \$QIO.

For additional information about system service completion, refer to the Synchronize (\$SYNCH) service.

On Alpha and Integrity server systems, this service accepts 64-bit addresses.

\$READ

Retrieves Bytes from File — The Read service retrieves a specified number of bytes from a file (beginning on a block boundary) and transfers them to memory. A Read service using block I/O can be performed on any file organization.

For additional information about this service, see the *VSI OpenVMS Record Management Services Reference Manual*.

\$READEF

Read Event Flags — Returns the current status of all 32 event flags in a local or common event flag cluster and indicates whether the specified event flag is set or clear. On Alpha and Integrity server systems, this service accepts 64-bit addresses.

Format

```
SYS$READEF efn ,state
```

C Prototype

```
int sys$readef (unsigned int efn, unsigned int *state);
```

Arguments

efn

OpenVMS usage:	ef_number
type:	longword (unsigned)
access:	read only
mechanism:	by value

Number of any event flag in the cluster whose status is to be returned. The *efn* argument is a longword containing this number; however, \$READEF uses only the low-order byte. Specifying an event flag within a cluster requests that \$READEF return the status of all event flags in that cluster.

There are two local event flag clusters, which are local to the process: cluster 0 and cluster 1. Cluster 0 contains event flag numbers 0 to 31, and cluster 1 contains event flag numbers 32 to 63.

There are two common event flag clusters: cluster 2 and cluster 3. Cluster 2 contains event flag numbers 64 to 95, and cluster 3 contains event flag numbers 96 to 127.

state

OpenVMS usage: mask_longword
type: longword (unsigned)
access: write only
mechanism: by 32- or 64-bit reference (Alpha and Integrity servers)

State of all event flags in the specified cluster. The *state* argument is the 32- or 64-bit address (on Alpha and Integrity server systems) of a longword into which \$READEF writes the state (set or clear) of the 32 event flags in the cluster.

Condition Values Returned

SS\$_WASCLR

The service completed successfully. The specified event flag is clear. Note that this is also the same value as SS\$_NORMAL.

SS\$_WASSET

The service completed successfully. The specified event flag is set. Note that while the message id is the same as SS\$_ACCVIO, the severity bits are different.

SS\$_ACCVIO

The longword that is to receive the current state of all event flags in the cluster cannot be written by the caller.

SS\$_ILLEFC

You specified an illegal event flag number.

SS\$_UNASEFC

The process is not associated with the cluster containing the specified event flag.

\$REGISTRY (Alpha and Integrity servers)

Interface to the OpenVMS Registry Database — On Alpha and Integrity server systems, interface to the OpenVMS Registry database server. The \$REGISTRY service allows you to query, update, and set keys, subkeys, and values in the OpenVMS Registry database. The \$REGISTRY service supports both asynchronous and synchronous operations. For asynchronous completion, use the Registry

(\$REGISTRY) system service. For synchronous completion, use the Registry and Wait (\$REGISTRYW) system service. The \$REGISTRYW system service is identical to the \$REGISTRY system service, except that \$REGISTRYW returns to the caller after the system completes the requested operation. For additional information about system service completion, see the Synchronize (\$SYNCH) system service. This system service is 64-bit compatible.

Format

```
SYSS$REGISTRY
    [efn] ,func ,0 ,itmlst ,[iosb or iosb_64] [,astadr or astadr_64]
    [,astprm or astprm_64] [,timeout]
```

C Prototype

```
int sys$registry
(unsigned int efn, unsigned int func, void *, void *itmlst,
 struct _iosb *iosb, ...);
```

Arguments

efn

OpenVMS usage: ef_number
type: longword (unsigned)
access: read only
mechanism: by value

Number of the event flag to be used by \$REGISTRY. If you do not specify the event flag, the system defaults to event flag 0. The event flag is initially cleared by \$REGISTRY and then set when the operation completes.

func

OpenVMS usage: function_code
type: longword (unsigned)
access: read only
mechanism: by value

Function code specifying the action that \$REGISTRY is to perform. The *func* argument is a longword containing this function code. The function code can contain function modifiers. For more information on function modifiers, see the Function Modifiers section.

A single call to \$REGISTRY can specify only one function code. All function codes require additional information to be passed in the call with the *itmlst* argument.

itmlst

OpenVMS usage: 32-bit item_list_3 or 64-bit item_list_64b
type: longword (unsigned) for 32-bit; quadword (unsigned) for 64-bit
access: read only

mechanism: by 32- or 64-bit reference

Item list supplying information that the system will use to perform the function specified by the *func* argument.

The *itmlst* argument is the address of the item list. The item list consists of one or more sets of item descriptors. Each descriptor is either an *item_list_3* or *item_list_64b* format.

Some function codes allow you to specify multiple operations in a single call. In this case, you must place the *REG\$_SEPARATOR* item code between each set of item codes. Each request, separated by a *REG\$_SEPARATOR* item code, can contain the item codes in any order.

You can specify item codes as either input or output parameters. Input parameters modify functions, set context, or describe the information to be returned. Output parameters return the requested information.

For *item_list_3* lists, you must terminate the list with a longword of 0. For *item_list_64b* lists, you must terminate the list with a quadword of 0.

The following diagram shows the structure of an *item_list_3* descriptor:

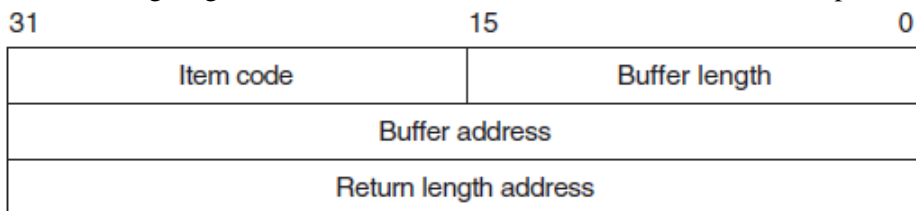

ZK-5186A-GE

The following diagram shows the structure of an *item_list_64b* descriptor:

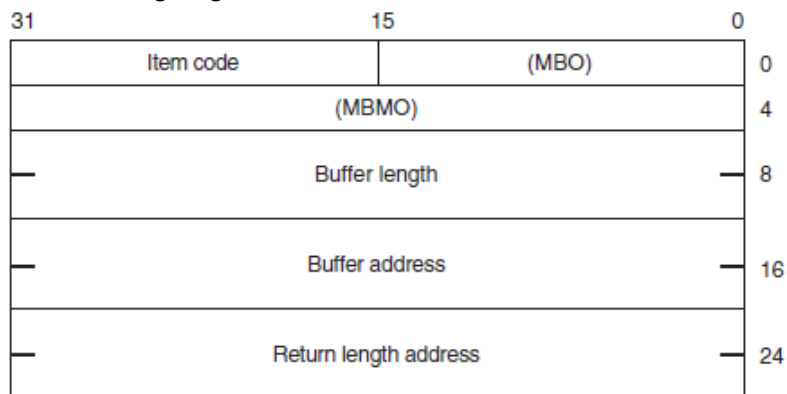

ZK-8782A-AI

The following table defines the item descriptor fields:

Descriptor Field	Definition
Buffer length	A word that specifies the length of the buffer. The buffer either supplies information to be used by \$REGISTRY, or receives information from \$REGISTRY. The required length of the buffer varies, depending on the item code specified. Each item code description specifies the required length.
Item code	A word containing a symbolic code that describes the type of information currently in the buffer or that is returned in the buffer. The buffer address field points to the location of the buffer.

Descriptor Field	Definition
Buffer address	A longword that contains the address of the buffer that specifies or receives the information.
Return length address	A longword that contains the address of a word that specifies the actual length in bytes of the information returned by \$REGISTRY. The information resides in a buffer identified by the buffer address field. The field applies to output item list entries only, and must be 0 (zero) for input entries. If the return length address is 0, it is ignored.

iosb or iosb_64

OpenVMS usage: status_block
type: buffer
access: write only
mechanism: by reference

Status block to receive the final completion status and information of the \$REGISTRY operation.

If multiple operations are requested for a function code, the value returned in *iosb* is either `SS$_NORMAL` or `SS$_REGERROR`.

A more specific return status for each operation is returned in the `REG$_RETURNSTATUS` item code (if specified).

The *iosb* argument is the address of the \$REGISTRY status block:

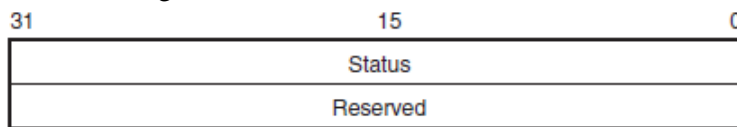

VM-0226A-AI

When \$REGISTRY begins execution, it clears the quadword I/O status block if you specify the **iosb** argument.

Although the *iosb* argument is optional, VSI strongly recommends that you specify it for the following reasons:

- If you are using an event flag to signal the completion of the service, you can test the I/O status block for a condition value to be sure that the event flag was not set by an event other than service completion.
- If you are using the \$SYNCH system service to synchronize completion of the service, the I/O status block is a required argument for \$SYNCH.

The condition value returned in R0 and the condition value returned in the I/O status block provide information about different aspects of the call to the \$REGISTRY service. The condition value returned in R0 provides information about the success or failure of the service call itself; the condition value returned in the I/O status block provides information about the success or failure of the service operation.

To assess the success or failure of the call to \$REGISTRY accurately, you must first check the condition value returned in R0. If R0 contains a successful value, you must check the condition value in the I/O status block.

The following table defines the item descriptor fields:

Descriptor Field	Definition
Status	A longword specifying the final status of the \$REGISTRY service. If you request multiple operations for a function code, the system returns either SSS_NORMAL or SSS_REGERROR to <i>iosb</i> . This field is set to 0 (zero) when the operation begins.
Reserved	A reserved longword.

astadr or astadr_64

OpenVMS usage: ast_procedure
 type: procedure value
 access: call without stack unwinding
 mechanism: by reference

AST service routine to be executed when \$REGISTRY completes. The *astadr* argument is the address of this routine. If you specify *astadr*, the AST routine executes at the same access mode as the caller of the \$REGISTRY service.

If the \$REGISTRY service is not called successfully (that is, if it returns an error immediately), the AST routine is not executed.

astprm or astprm_64

OpenVMS usage: user_arg
 type: longword (unsigned)
 access: read only
 mechanism: by value

AST parameter to be passed to the AST service routine specified by the *astadr* argument. The *astprm* argument specifies this longword parameter.

timeout

OpenVMS usage: longword_unsigned
 type: longword (unsigned)
 access: read only
 mechanism: by value

Timeout value specifies the number of seconds allotted to \$REGISTRY to perform the request. If the Registry server does not complete the request within the time you allot, \$REGISTRY returns REG\$_NORESPONSE.

Function Codes

Table 6 provides a summary of valid function codes, a brief description of their function, and the OpenVMS Registry rights identifier required to perform the function.

You can find a detailed description of each item code in the Item Codes section.

The OpenVMS Registry identifier is required only if you do not provide a valid NT access token and you do not have the SYSPRV privilege. If you have a granted REG\$UPDATE identifier, you can perform all the functions in Table 6.

Table 6. Valid Function Codes

Function Code	Identifier	Description
REG\$FC_CLOSE_KEY	REG\$LOOKUP	Closes an open key or subkey.
REG\$FC_CREATE_KEY	REG\$UPDATE	Creates (and opens) a subkey.
REG\$FC_DELETE_KEY	REG\$UPDATE	Removes a subkey from a key.
REG\$FC_DELETE_VALUE	REG\$UPDATE	Removes a value from a key.
REG\$FC_ENUM_KEY	REG\$LOOKUP	Lists (enumerates) the subkeys of a key.
REG\$FC_ENUM_VALUE	REG\$LOOKUP	Lists (enumerates) the values of a key.
REG\$FC_FLUSH_KEY	REG\$UPDATE	Ensures that all information for the key is backed to disk.
REG\$FC_MODIFY_KEY	REG\$UPDATE	Modifies a key.
REG\$FC_MODIFY_TREE_KEY	REG\$UPDATE	Modifies a key and all its subkeys.
REG\$FC_NOTIFY_CHANGE_KEY_VALUE	REG\$UPDATE	Notifies when a key or value has changed.
REG\$FC_OPEN_KEY	REG\$LOOKUP	Opens a key or subkey.
REG\$FC_QUERY_KEY	REG\$LOOKUP	Fetches information about a key.
REG\$FC_QUERY_VALUE	REG\$LOOKUP	Fetches information about a value.
REG\$FC_SEARCH_TREE_DATA	REG\$LOOKUP	Searches the value data of key and its subkeys.
REG\$FC_SEARCH_TREE_KEY	REG\$LOOKUP	Searches the names of a key and its subkeys.
REG\$FC_SEARCH_TREE_VALUE	REG\$LOOKUP	Searches the values of a key and its subkeys.
REG\$FC_SET_VALUE	REG\$UPDATE	Changes the data associated with a value name.

REG\$FC_CLOSE_KEY

This request releases the open resources of the specified key. If REG\$_KEYID indicates a predefined key, the system ignores the action and returns success.

Specify the item codes as follows:

Item Code	Required	Parameter Type
REG\$_KEYID	Yes	Input
REG\$_RETURNSTATUS	No	Output

REG\$FC_CREATE_KEY

If the key does not exist, this request creates a new subkey under the key specified by REG\$_KEYID. If the key does exist, the system does not modify it.

If you specify the REG\$_KEYRESULT item code, the system opens the specified subkey.

The system returns the result in the REG\$_DISPOSITION item code buffer.

Using this function code, you can group multiple requests into a single call to the \$REGISTRY service. To use the multiple-request feature, you must use the REG\$_SEPARATOR item code to indicate the end of the set of item codes for the current request and that there is another request to process.

To set a value for a key, call the \$REGISTRY service with the REG\$FC_SET_VALUE function code.

Specify the item codes as follows:

Item Code	Required	Parameter Type
REG\$_CACHEACTION	No	Input
REG\$_CLASSNAME	No	Input (Pointer to Unicode string. Unicode character is 4 bytes long.)
REG\$_DISPOSITION	No	Output
REG\$_KEYID	Yes	Input
REG\$_KEYRESULT	No	Output
REG\$_LINKPATH	No	Input (Pointer to Unicode string. Unicode character is 4 bytes long.)
REG\$_LINKTYPE	No	Input
REG\$_RETURNSTATUS	No	Output
REG\$_SECACCESS	No	Input
REG\$_SECURITYPOLICY	No	Input
REG\$_SEPARATOR	No	n/a
REG\$_SUBKEYNAME	Yes	Input (Pointer to Unicode string. Unicode character is 4 bytes long.)
REG\$_VOLATILE	No	Input

If you specify the REG\$_LINKPATH item code, it must point to a key path already defined in the OpenVMS Registry; otherwise the system returns the REG\$_INVALIDPATH error.

Note

If you do not specify the REG\$_CACHEACTION item code, the new key is created with the same cache action value as the parent key. The same rule applies to the REG\$_VOLATILE and REG\$_SECURITYPOLICY item codes.

REG\$FC_DELETE_KEY

This request removes the specified subkey and its values from the OpenVMS Registry database. If the specified key has subkeys, the key is not deleted. You must delete the subkeys first.

Using this function code, you can group multiple requests into a single call to the \$REGISTRY service. If you use this multiple-request feature, use the REG\$_SEPARATOR item code to indicate the end of the set of item codes for the current request and that there is another request to process.

Specify the item codes as follows:

Item Code	Required	Parameter Type
REG\$_KEYID	Yes	Input
REG\$_KEYPATH	No	Input (Pointer to Unicode string. Unicode character is 4 bytes long.)
REG\$_RETURNSTATUS	No	Output
REG\$_SEPARATOR	No	n/a
REG\$_SUBKEYNAME	Yes	Input (Pointer to Unicode string. Unicode character is 4 bytes long.)

REG\$FC_DELETE_VALUE

This request deletes the specified value from the key.

Using this function code, you can group multiple requests into a single call to the \$REGISTRY service. If you use this multiple-request feature, use the REG\$_SEPARATOR item code to indicate the end of the set of item codes for the current request and that there is another request to process.

Specify the item codes as follows:

Item Code	Required	Parameter Type
REG\$_KEYID	Yes	Input
REG\$_KEYPATH	No	Input (Pointer to Unicode string. Unicode character is 4 bytes long.)
REG\$_RETURNSTATUS	No	Output
REG\$_SEPARATOR	No	n/a
REG\$_VALUENAME	Yes	Input

REG\$FC_ENUM_KEY

This request retrieves information about one subkey of the key. You identify the subkey in the REG\$_SUBKEYINDEX item code.

To enumerate all the key's subkeys, the application must call the \$REGISTRY service repeatedly using the REG\$FC_ENUM_KEY function code. Begin with a REG\$_SUBKEYINDEX of zero, then increment the count until the request returns a REG\$_NOMOREITEMS error.

Specify the item codes as follows:

Item Code	Required	Parameter Type
REG\$_CACHEACTION	No	Output
REG\$_CLASSNAME	No	Output (Pointer to Unicode string. Unicode character is 4 bytes long.)
REG\$_KEYID	Yes	Input
REG\$_KEYPATH	No	Input (Pointer to Unicode string. Unicode character is 4 bytes long.)
REG\$_LASTWRITE	No	Output
REG\$_LINKCOUNT	No	Output

Item Code	Required	Parameter Type
REG\$_LINKPATH	No	Output (Pointer to Unicode string. Unicode character is 4 bytes long.)
REG\$_LINKTYPE	No	Output
REG\$_RETURNSTATUS	No	Output
REG\$_SECURITYPOLICY	No	Output
REG\$_SUBKEYINDEX	Yes	Input
REG\$_SUBKEYNAME	No	Output (Pointer to Unicode string. Unicode character is 4 bytes long.)
REG\$_VOLATILE	No	Output

REG\$FC_ENUM_VALUE

This request retrieves information about a value of the specified key identifier. The value to retrieve is identified in the REG\$_VALUEINDEX item code.

To enumerate all a key's values, the application must call the \$REGISTRY service repeatedly using the REG\$FC_ENUM_VALUE function code. Begin with a REG\$_VALUEINDEX of zero, then increment the count until the request returns a REG\$_NOMOREITEMS error.

Specify the item codes as follows:

Item Code	Required	Parameter Type
REG\$_DATAFLAGS	No	Output
REG\$_DATATYPE	No	Output
REG\$_KEYID	Yes	Input
REG\$_KEYPATH	No	Input (Pointer to Unicode string. Unicode character is 4 bytes long.)
REG\$_RETURNSTATUS	No	Output
REG\$_VALUEDATA	No	Output
REG\$_VALUEDATASIZE	No	Output
REG\$_VALUEINDEX	Yes	Input
REG\$_VALUENAME	No	Output
REG\$_VOLATILE	No	Output

REG\$FC_FLUSH_KEY

This request writes all the information about a specified key to disk.

This request returns only after the operation is complete and all attributes of the key have been written to the OpenVMS Registry database.

Specify the item codes as follows:

Item Code	Required	Parameter Type
REG\$_KEYID	Yes	Input
REG\$_KEYPATH	No	Input (Pointer to Unicode string. Unicode character is 4 bytes long.)

Item Code	Required	Parameter Type
REG\$_RETURNSTATUS	No	Output

REG\$FC_MODIFY_KEY

This request modifies a specified key's attributes.

Specify the item codes as follows:

Item Code	Required	Parameter Type
REG\$_CACHEACTION	No	Input
REG\$_CLASSNAME	No	Input (Pointer to Unicode string. Unicode character is 4 bytes long.)
REG\$_KEYID	Yes	Input
REG\$_KEYPATH	No	Input (Pointer to Unicode string. Unicode character is 4 bytes long.)
REG\$_LINKPATH	No	Input (Pointer to Unicode string. Unicode character is 4 bytes long.)
REG\$_LINKTYPE	No	Input
REG\$_NEWNAME	No	Input
REG\$_RETURNSTATUS	No	Output
REG\$_SECURITYPOLICY	No	Input

To remove the link from the specified key, enter a REG\$_LINKPATH item code with an address of zero. You cannot add a link to a key that has either values or subkeys (or both).

REG\$FC_MODIFY_TREE_KEY

This request modifies a specified key and all its subkey attributes. No link will be followed or modified.

Specify the item codes as follows:

Item Code	Required	Parameter Type
REG\$_CACHEACTION	No	Input
REG\$_CLASSNAME	No	Input (Pointer to Unicode string. Unicode character is 4 bytes long.)
REG\$_KEYID	Yes	Input
REG\$_KEYPATH	No	Input (Pointer to Unicode string. Unicode character is 4 bytes long.)
REG\$_RETURNSTATUS	No	Output
REG\$_SECURITYPOLICY	No	Input

REG\$FC_NOTIFY_CHANGE_KEY_VALUE

This request notifies the calling process when a specified key or any of its subkeys has changed. That is, the requested function waits for the specified condition before returning.

Specify the item codes as follows:

Item Code	Required	Parameter Type
REG\$_FLAGSUBKEY	Yes	Input
REG\$_KEYID	Yes	Input
REG\$_KEYPATH	No	Input (Pointer to Unicode string. Unicode character is 4 bytes long.)
REG\$_NOTIFYFILTER	Yes	Input
REG\$_RETURNSTATUS	No	Output

REG\$FC_OPEN_KEY

This request opens the specified key. If you do not specify a subkey, the system opens the key specified in REG\$_KEYID.

If REG\$_KEYID specifies a key other than a predefined key, the system opens the key again (duplicates the key).

Specify the item codes as follows:

Item Code	Required	Parameter Type
REG\$_KEYID	Yes	Input
REG\$_KEYRESULT	Yes	Output
REG\$_KEYPATH	No	Input (Pointer to Unicode string. Unicode character is 4 bytes long.)
REG\$_RETURNSTATUS	No	Output
REG\$_SECACCESS	Yes	Input
REG\$_SUBKEYNAME	No	Input (Pointer to Unicode string. Unicode character is 4 bytes long.)

REG\$FC_QUERY_KEY

This request retrieves attributes about a specified key.

Specify the item codes as follows:

Item Code	Required	Parameter Type
REG\$_CACHEACTION	No	Output
REG\$_CLASSNAME	No	Output (Pointer to Unicode string. Unicode character is 4 bytes long.)
REG\$_CLASSNAMEMAX	No	Output
REG\$_KEYID	Yes	Input
REG\$_KEYPATH	No	Input (Pointer to Unicode string. Unicode character is 4 bytes long.)
REG\$_LASTWRITE	No	Output
REG\$_LINKCOUNT	No	Output
REG\$_LINKPATH	No	Output (Pointer to Unicode string. Unicode character is 4 bytes long.)

Item Code	Required	Parameter Type
REG\$_LINKTYPE	No	Output
REG\$_RETURNSTATUS	No	Output
REG\$_SECURITYPOLICY	No	Output
REG\$_SUBKEYNAMEMAX	No	Output
REG\$_SUBKEYSNUMBER	Yes	Output
REG\$_VALUEDATAMAX	No	Output
REG\$_VALUENAMEMAX	No	Output
REG\$_VALUENUMBER	No	Output
REG\$_VOLATILE	No	Output

REG\$FC_QUERY_VALUE

This request retrieves the type, data flags, and data for the specified value name.

Using this function code, you can group multiple requests into a single call to the \$REGISTRY service.

If you use this multiple-request feature, use the REG\$_SEPARATOR item code to indicate the end of the set of item codes for the current request and that there is another request to process.

Specify the item codes as follows:

Item Code	Required	Parameter Type
REG\$_DATAFLAGS	No	Output
REG\$_DATATYPE	No	Output
REG\$_KEYPATH	No	Input (Pointer to Unicode string. Unicode character is 4 bytes long.)
REG\$_KEYID	Yes	Input
REG\$_LINKCOUNT	No	Output
REG\$_LINKPATH	No	Output (Pointer to Unicode string. Unicode character is 4 bytes long.)
REG\$_LINKTYPE	No	Output
REG\$_RETURNSTATUS	No	Output
REG\$_SEPARATOR	No	n/a
REG\$_VALUEDATA	No	Output
REG\$_VALUEDATASIZE	No	Output
REG\$_VALUENAME	Yes	Input
REG\$_VOLATILE	No	Output

REG\$FC_SEARCH_TREE_DATA

This request scans a specified key and all its descendants for a match with a specified set of data information.

The set of data information can be either the REG\$_DATAFLAGS item code, or the pair REG\$_DATATYPE and REG\$_VALUEDATA item codes, or all three item codes.

The REG\$_FLAGOPCODE item code specifies how the REG\$_DATAFLAGS item code should be matched against the database. (See the item codes description for more information about the REG\$_FLAGOPCODE item code.)

Every time the system finds a match, it appends the path name relative to the specified key to the REG\$_PATHBUFFER item code. A Unicode null character is used to separate the value path names.

If the buffer supplied by the application is not big enough to hold all the value path names found, the system returns the SS\$_BUFFEROVF error message in the *iosb* argument, and the length required to complete the operation successfully is returned in the REG\$_REQLENGTH item (if specified).

Use the ellipsis (...) wildcard to match zero or more subkeys in the REG\$_KEYPATH item code.

(For example, Hardware\...\disks finds all the paths that start with the Hardware subkey and end with the disk subkey, with zero or more subkeys in between.)

Use the asterisk (*) wildcard to match an entire subkey or a portion of a subkey in the REG\$_KEYPATH item code.

Use the percent (%) wildcard to match one character in a key name in the REG\$_KEYPATH item code.

Specify the item codes as follows:

Item Code	Required	Parameter Type
REG\$_DATAFLAGS	No	Input
REG\$_DATATYPE	No	Input
REG\$_FLAGOPCODE	No	Input
REG\$_KEYPATH	No	Input (Pointer to Unicode string. Unicode character is 4 bytes long.)
REG\$_KEYID	Yes	Input
REG\$_PATHBUFFER	Yes	Output
REG\$_REQLENGTH	No	Output
REG\$_RETURNSTATUS	No	Output
REG\$_VALUEDATA	No	Input

REG\$FC_SEARCH_TREE_KEY

This request scans a specified key and all its descendants for a specified key path.

For this function code, a valid key path is a Unicode string that can include the ellipsis (...), asterisk (*), or percent (%) wildcard character, but that cannot start with the backslash character (\).

Use the ellipsis (...) wildcard to match zero or more subkeys in the REG\$_KEYPATH item code. (For example, Hardware\...\disks finds all the paths that start with the Hardware subkey and end with the disk subkey, with zero or more subkeys in between.)

Use the asterisk (*) wildcard to match an entire subkey or a portion of a subkey in the REG\$_KEYPATH item code.

Use the percent (%) wildcard to match one character in a key name in the REG\$_KEYPATH item code.

An example of a valid key path is as follows:

```
hardware\system\*\disk%%
```

Every time the system finds a match, the system appends its path name relative to the specified key identifier to the REG\$_PATHBUFFER item code. A Unicode null character (4 bytes) separates the subkey path names.

If the buffer supplied by the application is not big enough to contain all the subkey path names found, the system returns the SS\$_BUFFEROVF error message in the *iosb* argument, and the system returns the required length to complete the operation successfully in the REG\$_REQLENGTH item (if specified).

Specify the item codes as follows:

Item Code	Required	Parameter Type
REG\$_KEYID	Yes	Input
REG\$_KEYPATH	No	Input (Pointer to Unicode string. Unicode character is 4 bytes long.)
REG\$_PATHBUFFER	Yes	Output
REG\$_REQLENGTH	No	Output
REG\$_RETURNSTATUS	No	Output

REG\$FC_SEARCH_TREE_VALUE

This request scans a specified key and all its descendants for a specified value name.

For this function code a valid key name is a Unicode string that can include the ellipsis (...), asterisk (*), or percent (%) wildcard character, but cannot start with the backslash character (\).

Use the ellipsis (...) wildcard to match zero or more subkeys in the REG\$_KEYPATH item code. (For example, Hardware\...\disks finds all the paths that start with the Hardware subkey and end with the disk subkey, with zero or more subkeys in between.)

Use the asterisk (*) wildcard to match an entire subkey or a portion of a subkey in the REG\$_KEYPATH item code.

Use the percent (%) wildcard to match one character in a key name in the REG\$_KEYPATH item code.

An example of a valid key path is as follows:

```
hardware\system\...
```

For this function code, a valid name is a Unicode string that can include the asterisk (*) and percent (%) wildcard characters.

Every time the system finds a match, the system appends its path name relative to the specified key identifier to the REG\$_PATHBUFFER item code. A Unicode null character (4 bytes) separates the subkey path names.

If the buffer supplied by the application is not big enough to contain all the subkey path names found, the system returns the SS\$_BUFFEROVF error message in the *iosb* argument, and the system returns the required length to complete the operation successfully in the REG\$_REQLENGTH item (if specified).

Specify the item codes as follows:

Item Code	Required	Parameter Type
REG\$_KEYPATH	No	Input (Pointer to Unicode string. Unicode character is 4 bytes long.)
REG\$_KEYID	Yes	Input
REG\$_PATHBUFFER	Yes	Output
REG\$_REQLENGTH	No	Output
REG\$_RETURNSTATUS	No	Output
REG\$_VALUENAME	Yes	Input

REG\$FC_SET_VALUE

This request sets value and type information for a specified key.

Using this function code, you can group multiple requests into a single call to the \$REGISTRY service.

If you use this multiple-request feature, use the REG\$_SEPARATOR item code to indicate the end of the set of item codes for the current request and that there is another request to process.

When a value is set to a link, the system validates the link unless you specify the REG\$_M_IGNORE_LINKS function code modifier.

Specify the item codes as follows:

Item Code	Required	Parameter Type
REG\$_DATAFLAGS	No	Input
REG\$_DATATYPE	No	Input
REG\$_KEYID	Yes	Input
REG\$_KEYPATH	No	Input (Pointer to Unicode string. Unicode character is 4 bytes long.)
REG\$_LINKPATH	No	Input (Pointer to Unicode string. Unicode character is 4 bytes long.)
REG\$_LINKTYPE	No	Input
REG\$_RETURNSTATUS	No	Output
REG\$_SEPARATOR	No	n/a
REG\$_VALUEDATA	No	Input
REG\$_VALUENAME	No	Input

Item Codes

Table 7 provides a summary of item codes that are valid as an item descriptor in the *itmlst* argument. The table lists the item codes, input/output usage, and data types.

Complete descriptions of each item code are provided in the sections that follow this table.

Table 7. Item Code Summary

Item Code	Input/Output	Data Type
REG\$_CACHEACTION	Input, output	Longword

Item Code	Input/Output	Data Type
REG\$_CLASSNAME	Input, output	(Pointer to Unicode string. Unicode character is 4 bytes long.)
REG\$_CLASSNAMEMAX	Output	Longword
REG\$_DATAFLAGS	Input, output	Quadword
REG\$_DATATYPE	Input, output	Longword
REG\$_DISPOSITION	Output	Longword
REG\$_FLAGOPCODE	Input	Longword
REG\$_FLAGSUBKEY	Input	Longword
REG\$_KEYID	Input, output	Longword
REG\$_KEYPATH	Input	(Pointer to Unicode string. Unicode character is 4 bytes long.)
REG\$_KEYRESULT	Output	Longword
REG\$_LASTWRITE	Output	Quadword
REG\$_LINKCOUNT	Output	Longword
REG\$_LINKPATH	Input, output	(Pointer to Unicode string. Unicode character is 4 bytes long.)
REG\$_LINKTYPE	Input, output	Longword
REG\$_NEWNAME	Input	Unicode string
REG\$_NOTIFYFILTER	Input	Longword
REG\$_PATHBUFFER	Output	Buffer
REG\$_REQLENGTH	Output	Longword
REG\$_RETURNSTATUS	Output	Longword
REG\$_SECACCESS	Input	Longword
REG\$_SECURITYPOLICY	Input, output	Longword
REG\$_SEPARATOR	n/a	None
REG\$_SUBKEYINDEX	Input	Longword
REG\$_SUBKEYNAME	Input, output	(Pointer to Unicode string. Unicode character is 4 bytes long.)
REG\$_SUBKEYNAMEMAX	Output	Longword
REG\$_SUBKEYSNUMBER	Output	Longword
REG\$_VALUEDATA	Input, output	Buffer
REG\$_VALUEDATAMAX	Output	Longword
REG\$_VALUEDATASIZE	Output	Longword
REG\$_VALUEINDEX	Input	Longword
REG\$_VALUENAME	Input, output	Unicode string
REG\$_VALUENAMEMAX	Output	Longword
REG\$_VALUENUMBER	Output	Longword
REG\$_VOLATILE	Input, output	Longword

REG\$_CACHEACTION

The REG\$_CACHEACTION item code is an input item code. It is a longword flag that specifies whether the information on a specified object should be written to disk immediately. It takes one of the following values:

Cache Value	Description
REG\$_WRITEBEHIND	Write information about the specified object written to disk at a later time (default).
REG\$_WRITETHRU	Write information about the specified object to disk immediately.

Note

If you do not specify this item code, the value or key inherits its value from the parent object. By default, the entry points (REG\$_HKEY_CLASSES_ROOT, REG\$_HKEY_LOCAL_MACHINE, and REG\$_HKEY_USERS) are set with a value equal to that of REG\$_WRITEBEHIND.

REG\$_CLASSNAME

The REG\$_CLASSNAME item code is, depending on the function code, either an input or output item code.

The class name is an information field for a key. The type of an object is an example of a class name. It can be composed of any string of Unicode characters. A Unicode character is 4 bytes long.

REG\$_CLASSNAMEMAX

The REG\$_CLASSNAMEMAX item code is an output item code. It receives the length, in bytes, of the longest string specifying a subkey class name.

REG\$_DATAFLAGS

Depending on the function code, the REG\$_DATAFLAGS item code is either an input or output item code. It is a 64-bit application-dependent value data flag.

REG\$_DATATYPE

Depending on the function code, the REG\$_DATATYPE item code is either an input or output item code.

It is a longword that either specifies the type of information to be stored as a value data or receives the type of information of a specified value data component.

It takes one of the following values:

Type code	Description
REG\$_BINARY	Binary data
REG\$_DWORD	A 32-bit number
REG\$_EXPAND_SZ	A string of Unicode characters
REG\$_MULTI_SZ	A concatenated array of REG\$_SZ strings
REG\$_NONE	No defined value type (default)
REG\$_QWORD	A 64-bit number
REG\$_SZ	A null-terminated Unicode string

Note

The difference between REG\$K_EXPAND_SZ and REG\$K_SZ:

A string is a set of characters usually in human-readable form. Many value entries in the OpenVMS Registry are written using a **string** (REG_SZ) or an **expandable string** (REG_EXPAND_SZ) format.

An expandable string is usually human-readable text, but it can also include a variable that will be replaced when the string is called by an application.

For example, on a Windows NT system, in the value entry %SystemRoot%\System32\Bootok.exe, %SystemRoot% is the expandable portion of the variable. This part is replaced with the actual location of the directory that contains the Windows NT system files.

REG\$_DISPOSITION

The REG\$_DISPOSITION item code is an output item code. It is a longword and takes one of the following values:

Disposition value	Description
REG\$K_CREATENEWKEY	The key did not exist and was created.
REG\$K_OPENEXISTINGKEY	The key existed and was opened.

REG\$_FLAGOPCODE

The REG\$_FLAGOPCODE item code is an input item code. It is a longword flag that indicates how the REG\$_DATAFLAGS input item code should be matched against the data flags field in the OpenVMS Registry database. It takes one of the following values:

Operator code options	Description
REG\$K_ANY	The data field in the OpenVMS Registry database must contain at least one of the flags in the REG\$_DATAFLAGS input item code.
REG\$K_EXACTMATCH	The REG\$_DATAFLAGS input item code must match exactly the data flags field in the OpenVMS Registry database.
REG\$K_EXCLUDE	The data flags field in the OpenVMS Registry database must <i>not</i> contain the flags in the REG\$_DATAFLAGS input item code.
REG\$K_INCLUDE	The data flags field in the OpenVMS Registry database must contain, at a minimum, the flags in the REG\$_DATAFLAGS input item code.
REG\$K_NOTANY	The data field in the OpenVMS Registry database must <i>not</i> contain any of the flags in the REG\$_DATAFLAGS input item code.

REG\$_FLAGSUBKEY

The REG\$_FLAGSUBKEY item code is an input item code. It is a longword Boolean field that indicates the following:

- If set to 1, report changes in a specified key and any of its subkeys.
- If set to 0, report changes to a specified key only.

REG\$_KEYID

The REG\$_KEYID item code is an input item code. It is a longword that contains the key identifier.

REG\$_KEYRESULT

The REG\$_KEYRESULT item code is an output item code. It is a longword that receives a key identifier. The key identifier can be passed to other Registry calls using the REG\$_KEYID item code.

REG\$_KEYPATH

The REG\$_KEYPATH item code is an input item code. It is a string of Unicode characters that specifies a key path. A Unicode character is 4 bytes long.

REG\$_LASTWRITE

The REG\$_LASTWRITE item code is an output item code. It is a quadword representation of absolute time that receives the time a specified key was last written to (including changes to its values).

REG\$_LINKCOUNT

The REG\$_LINKCOUNT item code is an output item code. It is longword count of the number of symbolic links that refer to the item.

REG\$_LINKPATH

The REG\$_LINKPATH item code is, depending on the function code, either an input or an output item code. It is a string of Unicode characters that specifies the key path to which a specified key is linked. A Unicode character is 4 bytes long.

REG\$_LINKTYPE

The REG\$_LINKTYPE item code is, depending on the function code, either an input or an output item code. It is longword type that indicates the link type.

Link Type	Description
REG\$K_NONE	No link (default)
REG\$K_SYMBOLICLINK	Symbolic (logical) link

REG\$_NEWNAME

The REG\$_NEWNAME item code is a string of Unicode characters that specifies the new name of the key.

REG\$_NOTIFYFILTER

The REG\$_NOTIFYFILTER item code is an input item code. It is a longword mask that specifies which changes to the specified key and its subkeys and values to report. It takes any combination of the following values:

Value	Description
REG\$M_CHANGEATTRIBUTES	An attribute change of the specified key or its subkeys.
REG\$M_CHANGELASTSET	Changes to the last write time of the specified key or its subkeys.
REG\$M_CHANGENAME	A key name change, including creation and deletion, of the specified key or its subkeys.

Note

The system report changes to subkeys of the specified key only if the REG\$_FLAGSUBKEY item code is set to 1.

REG\$_PATHBUFFER

The REG\$_PATHBUFFER item code is an output item code. It is a buffer that receives a set of either key paths or value paths, separated by a null Unicode character (4 bytes long). (The third longword of the item descriptor contains the number of bytes written to the buffer.)

REG\$_REQLENGTH

The REG\$_REQLENGTH item code is an output item code. It is a longword that receives the required buffer size (in bytes) to complete the operation successfully.

REG\$_RETURNSTATUS

The REG\$_RETURNSTATUS item code is an output item code. It is a longword that receives the final completion status for a specified operation. For more information, see the Condition Values Returned section.

REG\$_SECACCESS

The REG\$_SECACCESS item code is an input item code. It is a longword mask that specifies the desired security access for the new key. It takes any combination of the following values:

Security access mask	Description
REG\$_M_ALLACCESS	A combination of the following access values: REG\$_K_CREATELINK REG\$_K_CREATESUBKEY REG\$_K_ENUMSUBKEYS REG\$_K_NOTIFY REG\$_K_QUERYVALUE REG\$_K_SETVALUE
REG\$_M_CREATELINK	Allows creation of a symbolic link.
REG\$_M_CREATESUBKEY	Allows creation of subkeys.
REG\$_M_ENUMSUBKEYS	Allows enumeration of subkeys.
REG\$_M_EXECUTE	Allows read access.
REG\$_M_NOTIFY	Allows change notification.
REG\$_M_QUERYVALUE	Allows queries of subkey data.
REG\$_M_READ	A combination of the following access values: REG\$_K_ENUMSUBKEYS REG\$_K_QUERYVALUE REG\$_K_NOTIFY
REG\$_M_SETVALUE	Allows setting of values and data.
REG\$_M_WRITE	A combination of the following access values: REG\$_K_CREATESUBKEY

Security access mask	Description
	REG\$K_SETVALUE

REG\$_SECURITYPOLICY

The REG\$_SECURITYPOLICY item code is an input item code. It is a longword that specifies the security policy to enforce for the key.

It takes the following value:

Policy Setting	Description
REG\$K_POLICY_NT_40	Access is required to the first key and the requested key (default).

REG\$_SEPARATOR

The REG\$_SEPARATOR item code is an empty item code that provides a separator between sets of item codes.

Using this item code, you can group multiple requests into a single call to the \$REGISTRY service. If you use this multiple-request feature, use the REG\$_SEPARATOR item code to indicate the end of the set of item codes for the current request and that there is another request to process.

REG\$_SUBKEYINDEX

The REG\$_SUBKEYINDEX item code is an input item code. It is a longword that specifies the index of the subkey to retrieve.

REG\$_SUBKEYNAME

The REG\$_SUBKEYNAME item code is an input item code. It is a string of Unicode characters that specifies the name of a subkey. A Unicode character is 4 bytes long.

REG\$_SUBKEYNAMEMAX

The REG\$_SUBKEYNAMEMAX item code is an output item code. It is a longword that receives the length (in characters) of a specified key's longest subkey name.

REG\$_SUBKEYSNUMBER

The REG\$_SUBKEYSNUMBER item code is an output item code. It is a longword that receives the number of subkeys contained in a specified key.

REG\$_VALUEDATA

The REG\$_VALUEDATA item code is, depending on the function code, either an input or output item code. It is a buffer that contains either the value data component to write to the OpenVMS Registry (input), or it receives a data value component from the OpenVMS Registry (output).

REG\$_VALUEDATAMAX

The REG\$_VALUEDATAMAX item code is an output item code. It is a longword that receives the length (in bytes) of the specified key's longest data component value.

REG\$_VALUEDATASIZE

The REG\$_VALUEDATASIZE item code is an output item code. It is used to specify the address and size of a buffer that receives the length, in bytes, of the value data. The buffer size should be 4 bytes.

REG\$_VALUEINDEX

The REG\$_VALUEINDEX item code is an input item code. It is a longword that specifies the index of the value to retrieve within a specified key. Note that the value index starts at zero and can be any value up to one less than the count returned by REG\$_VALUENUMBER.

REG\$_VALUENAME

The REG\$_VALUENAME item code is, depending on the function code, either an input or an output item code. It is a string of Unicode characters that specifies the name of a value.

REG\$_VALUENAMEMAX

The REG\$_VALUENAMEMAX item code is an output item code. It is a longword that receives the length (in characters) of a specified key's longest value name.

REG\$_VALUENUMBER

The REG\$_VALUENUMBER item code is an output item code. It is a longword that receives the number of values contained in a specified key.

REG\$_VOLATILE

The REG\$_VOLATILE item code identifies the volatility of an item. As an output, it returns the volatility of the object. On OpenVMS, volatile keys and values are lost when all nodes running an OpenVMS Registry server are rebooted. (In a standalone system, volatile keys and values are lost when the system reboots.)

Volatile Type	Description
REG\$K_CLUSTER	The item is removed when the cluster reboots.
REG\$K_NONE	The item is not volatile (default).

Function Modifiers

You can optionally specify the high-order bits of a function code value with function modifiers. These individual bits can alter the operation of the function.

For example, you can specify the function modifier REG\$M_CASE_SENSITIVE with the function REG\$FC_CREATE_KEY. When you use the function and function modifier together, the data passed to the OpenVMS Registry is treated as case sensitive. The two values are written in VSI C as REG\$M_CASE_SENSITIVE IREG\$FC_CREATE_KEY.

The OpenVMS Registry function modifiers are defined in the header file REGDEF.H.

REG\$M_CASE_SENSITIVE

Use case sensitive matching for keys and values.

REG\$M_DISABLE_WILDCARDS

Treat wildcard characters as normal characters for this function.

REG\$M_IGNORE_LINKS

Force the operation to not follow any symbolic links associated with a key or a value.

By default, if a key or value is symbolically linked to another key or value, the system follows all links so that the operation specified by the function code is performed on the linked key or value.

When you specify the REG\$M_IGNORE_LINKS function modifier, the operation specified by the function code affects only the specified key or value, not the linked key or value.

By default, if a key or value has a symbolic link, it can not be deleted. If you specify the REG\$M_IGNORE_LINKS function modifier, the system deletes the key or value.

REG\$M_NOW

Write to disk immediately, regardless of the REG\$_CACHEACTION item code value.

Description

The \$REGISTRY service provides the means to create, delete and modify registry keys, key values, and key attributes.

The \$REGISTRY service uses process P1 space to store handles to keys.

The \$REGISTRY service must be called at IPL 0, and requires system dynamic memory to deliver AST requests.

Related Services

\$REGISTRYW

Condition Values Returned

SS\$_NORMAL

Normal successful completion.

SS\$_ACCVIO

One of the arguments cannot be read/written.

SS\$_BADPARAM

Function code or one of the item list code is invalid.

SS\$_EXASTLM

Exceeded AST limit.

SS\$_INSFARG

Insufficient number of argument supplied.

SS\$_INSFP1POOL

Not enough process P1 space available.

SS\$_NOIMPERSONATE

The caller does not have the privilege to obtain information about the specified personae.

SS\$_TOO_MANY_ARGS

Too many arguments.

REG\$_ACCESSDENIED

Requested access to key is denied.

REG\$_IPLTOOHIGH

Callers above IPL 0 cannot call this service.

Condition Values Returned in the I/O Status Block

SS\$_NORMAL

Normal successful completion.

SS\$_ACCVIO

One of the arguments cannot be read/written.

SS\$_BADPARAM

Function code or one of the item list code is invalid.

SS\$_EXASTLM

Exceeded AST limit.

SS\$_INSFARG

Insufficient number of argument supplied.

SS\$_INSFP1POOL

Not enough process P1 space available.

SS\$_NOIMPERSONATE

The caller does not have the privilege to obtain information about the specified personae.

SS\$_TOO_MANY_ARGS

Too many arguments.

REG\$_ACCESSDENIED

Requested access to key is denied.

REG\$_BUFFEROVF

Buffer overflow.

REG\$_DBALREADYLOADED

Database is already loaded.

REG\$_DBNOTYETLOADED

Database is not yet loaded.

REG\$_EXQUOTA

Registry file quota or page file quota exceeded.

REG\$_HASLINK

Key has a link to another key.

REG\$_HAVESUBKEYS

Cannot delete a key with subkeys.

REG\$_INTERNERR

Registry internal error.

REG\$_INVCACHEACTION

Invalid cache action parameter.

REG\$_INVCREENTIALS

NT credentials are not valid.

REG\$_INVDATA

Invalid data value.

REG\$_INVDATATYPE

Invalid data type parameter.

REG\$_INVFUNCCODE

Invalid function code.

REG\$_INVKEYFLAGS

Invalid key flags.

REG\$_INVKEYID

Key does not exist or invalid key ID was specified.

REG\$_INVKEYNAME

Invalid key name.

REG\$_INVLINK

Invalid link or link type.

REG\$_INVLINKPATH

Invalid link path.

REG\$_INVPARAM

Invalid parameter.

REG\$_INVPATH

Invalid key path.

REG\$_INVSECDESCRIPTOR

Invalid security descriptor.

REG\$_INVSECPOLICY

Invalid security policy parameter.

REG\$_INVVALNAME

Invalid value name.

REG\$_INVVOLROOTKEY

Cannot create a new file with a volatile root key.

REG\$_IPLTOOHIGH

Callers above IPL 0 cannot call this service.

REG\$_KEYCHANGED

Key or subkey has changed.

REG\$_KEYLOCKED

Key locked by another thread.

REG\$_KEYNAMEEXIST

Key name already exists.

REG\$_NOKEY

Specified key does not exist.

REG\$_NOMOREITEMS

No more items for specified key.

REG\$_NOPATHFOUND

Path not found.

REG\$_NORESPONSE

OpenVMS Registry server failed to respond within the allotted time period.

REG\$_NOTROOTKEY

Invalid root key index.

REG\$_NOTSUPPORTED

Function code, item code, or item value is not supported.

REG\$_NOVALUE

Specified value does not exist.

REG\$_REQRECEIVED

Received request for key change notification.

REG\$_RESERVED

Cannot delete or modify a reserved key or value.

REG\$_SECVIO

Violates the security access method specified when this key was last opened.

REG\$_STRINGTOOLONG

Input string too long.

REG\$_STRINGTRUNC

Output buffer is not large enough to contain the converted string.

REG\$_TOOMANYOPENKEY

Number of opened keys exceeds the limit.

REG\$_VALUEEXIST

Value already exists.

REG\$_VOLMISMATCH

Cannot create nonvolatile subkey for a volatile key.

This service can also return status values from the following system services: \$CLREF, \$SYNCH, \$PERSONA_EXTENSION_LOOKUP, and \$PERSONA_QUERY.

\$REGISTRYW (Alpha and Integrity servers)

Interface to the OpenVMS Registry Database and Wait — On Alpha and Integrity server systems, interface to the OpenVMS Registry database server. The \$REGISTRY service supports both asynchronous and synchronous operations. For asynchronous completion, use the Registry (\$REGISTRY) system service. For synchronous completion, use the Registry and Wait (\$REGISTRYW) system service. The \$REGISTRYW system service is identical to the \$REGISTRY system service, except that \$REGISTRYW returns to the caller after the system completes the requested operation. For

additional information about system service completion, see the Synchronize (\$SYNCH) system service. This system service is 64-bit compatible.

Format

```
SYSS$REGISTRYW  
    [efn] ,func ,0 ,itmlst ,[iosb or iosb_64] [,astadr or astadr_64]  
    [,astprm or astprm_64] [,timeout]
```

C Prototype

```
int sys$registryw  
    (unsigned int efn, unsigned int func, void *, void *itmlst,  
    struct _iosb *iosb, ...);
```

\$RELEASE

Unlocks Record — The Release service unlocks the record specified by the contents of the record file address (RAB\$W_RFA) field of the RAB.

For additional information about this service, see the *VSI OpenVMS Record Management Services Reference Manual*.

\$RELEASE_GALAXY_LOCK (Alpha Only)

Release OpenVMS Galaxy Lock — Releases ownership of an OpenVMS Galaxy lock. Note that this system service is supported only in an OpenVMS Alpha Galaxy environment. For more information about programming with OpenVMS Galaxy system services, see the *VSI OpenVMS Alpha Partitioning and Galaxy Guide*.

Format

```
SYSS$RELEASE_GALAXY_LOCK handle
```

C Prototype

```
int sys$release_galaxy_lock (unsigned __int64 lock_handle);
```

Arguments

handle

OpenVMS usage:	galaxy lock handle
type:	quadword (unsigned)
access:	read
mechanism:	input by value

The 64-bit lock handle that identifies the lock to be released. This value is returned by SYSS\$CREATE_GALAXY_LOCK.

Description

This service releases ownership of an OpenVMS Galaxy lock. Because a Galaxy lock can be acquired multiple times by the same owner (nested ownership), the lock is not released until the ownership count goes to zero. If the lock ownership is completely released and there are other threads waiting for the lock, they are released from their wait states.

Required Access or Privileges

Write access to lock.

Required Quota

None

Related Services

\$ACQUIRE_GALAXY_LOCK, \$CREATE_GALAXY_LOCK,
\$CREATE_GALAXY_LOCK_TABLE, \$DELETE_GALAXY_LOCK,
\$DELETE_GALAXY_LOCK_TABLE, \$GET_GALAXY_LOCK_INFO,
\$GET_GALAXY_LOCK_SIZE

Condition Values Returned

SS\$_NORMAL

Normal completion.

SS\$_IVLOCKID

Invalid lock id.

SS\$_IVLOCKOP

Invalid lock operation.

SS\$_IVLOCKTBL

Invalid lock table.

\$REMOVE

Deletes File Name — The Remove service deletes a file name from a directory. It is the reverse of the Enter service.

For additional information about this service, see the *VSI OpenVMS Record Management Services Reference Manual*.

\$REM_HOLDERS

Remove Holder Record from Rights Database — Deletes the specified holder record from the target identifier's list of holders.

Format

```
SYS$REM_HOLDER id ,holder
```

C Prototype

```
int sys$rem_holder (unsigned int id, struct _generic_64 *holder);
```

Arguments

id

OpenVMS usage: rights_id
type: longword (unsigned)
access: read only
mechanism: by value

Binary value of target identifier whose holder is deleted when \$REM_HOLDER completes execution. The *id* argument is a longword containing the identifier value.

holder

OpenVMS usage: rights_holder
type: quadword (unsigned)
access: read only
mechanism: by reference

Identifier of holder being deleted when \$REM_HOLDER completes execution. The *holder* argument is the address of a quadword containing the UIC identifier of the holder in the first longword and the value of 0 in the second longword.

Description

The Remove Holder Record from Rights Database service removes the specified holder record from the target identifier's list of holders.

Required Access or Privileges

Write access to the rights database is required.

Required Quota

None

Related Services

\$ADD_HOLDER, \$ADD_IDENT, \$ASCTOID, \$CREATE_RDB, \$FIND_HELD, \$FIND HOLDER,
\$FINISH_RDB, \$GRANTID, \$IDTOASC, \$MOD_HOLDER, \$MOD_IDENT, \$REM_IDENT,
\$REVOKID

Condition Values Returned

SS\$_NORMAL

The service completed successfully.

SS\$_ACCVIO

The *holder* argument cannot be read by the caller.

SS\$_INSFMEM

The process dynamic memory is insufficient for opening the rights database.

SS\$_IIDENT

The specified identifier or holder identifier is of invalid format.

SS\$_NORIGHTSDB

The rights database does not exist.

SS\$_NOSUCHID

The specified identifier does not exist in the rights database, or the specified holder identifier does not exist in the rights database.

RMS\$_PRV

The user does not have write access to the rights database.

Because the rights database is an indexed file accessed with OpenVMS RMS, this service can also return RMS status codes associated with operations on indexed files. For descriptions of these status codes, refer to the *VSI OpenVMS Record Management Services Reference Manual*.

\$REM_IDENT

Remove Identifier from Rights Database — Removes the specified identifier record and all its holder records (if any) from the rights database.

Format

```
SY$REM_IDENT id
```

C Prototype

```
int sys$rem_ident (unsigned int id);
```

Argument

id

OpenVMS usage: `rights_id`

type: longword (unsigned)
access: read only
mechanism: by value

Binary value of identifier deleted from rights database when \$REM_IDENT completes execution. The *id* argument is a longword containing the identifier value.

Description

The Remove Identifier from Rights Database service removes from the rights database the specified identifier record, all its holder records (if any), and all records in identifiers that the deleted identifier held.

Required Access or Privileges

Write access to the rights database is required.

Required Quota

None

Related Services

\$ADD HOLDER, \$ADD_IDENT, \$ASCTOID, \$CREATE_RDB, \$FIND_HELD, \$FIND HOLDER, \$FINISH_RDB, \$GRANTID, \$IDTOASC, \$MOD HOLDER, \$MOD_IDENT, \$REM HOLDER, \$REVOKID

Condition Values Returned

SS\$_NORMAL

The service completed successfully.

SS\$_INSFMEM

The process dynamic memory is insufficient for opening the rights database.

SS\$_IIDENT

The specified identifier is of invalid format.

SS\$_NORIGHTSDB

The rights database does not exist.

SS\$_NOSUCHID

The specified identifier does not exist in the rights database.

RMS\$_PRV

The user does not have write access to the rights database.

Because the rights database is an indexed file accessed with OpenVMS RMS, this service can also return RMS status codes associated with operations on indexed files. For descriptions of these status codes, refer to the *VSI OpenVMS Record Management Services Reference Manual*.

\$RENAME

Rename File — You can use the Rename service to change the name, type, or version of a file, or to move a file to another directory by changing its directory specification. However, you cannot use this service to move a file to another device.

For additional information about this service, see the *VSI OpenVMS Record Management Services Reference Manual*.

\$RESCHED

Reschedule Process — Requests reschedule of a process.

Format

SYS\$RESCHED

C Prototype

```
int sys$resched (void);
```

Arguments

None.

Description

The Reschedule Process service requests that the set of runnable processes on the system be evaluated by their priority, with the potential result that the current process may be descheduled and requeued.

\$RESCHED is intended to allow a process running at priority *n* to voluntarily relinquish the remainder of its run quantum to another process of the same priority. When the set of all runnable processes is evaluated, one of the following will occur:

1. The process executing \$RESCHED will be descheduled, while another process of equal or higher priority is selected to run. The descheduled process is placed at the end of its priority queue and all other processes at that priority will run before the process that called \$RESCHED runs again. When the process does run again, \$RESCHED completes and returns control to the application.
2. If, after the evaluation of all runnable processes, the process that executed \$RESCHED remains the highest-priority runnable process, that process remains current and continues to run. In this case, \$RESCHED returns immediately.

Required Access or Privileges

None

Required Quota

None

Related Services

None

Condition Values Returned

SS\$_NORMAL

The service completed successfully.

\$RESUME

Resume Process — Causes a process previously suspended by the Suspend Process (\$SUSPND) service to resume execution or cancels the effect of a subsequent suspend request.

Format

```
SYS$RESUME [pidadr] , [prcnam]
```

C Prototype

```
int sys$resume (unsigned int *pidadr, void *prcnam);
```

Arguments

pidadr

OpenVMS usage: process_id
type: longword (unsigned)
access: modify
mechanism: by reference

Process identification (PID) of the process to be resumed. The *pidadr* argument is the address of a longword containing the PID. The *pidadr* argument can refer to a process running on the local node or a process running on another node in the cluster.

You must specify the *pidadr* argument to delete processes in other UIC groups.

prcnam

OpenVMS usage: process_name
type: character-coded text string
access: read only
mechanism: by descriptor-fixed-length string descriptor

Name of the process to be resumed. The *prcnam* argument is the address of a character string descriptor pointing to the process name.

A process running on the local node can be identified with a 1- to 15-character string. To identify a process on a particular node on a cluster, specify the full process name, which includes the node name as well as the process name. The full process name can contain up to 23 characters.

You can use the *prcnam* argument to resume only processes in the same UIC group as the calling process, because process names are unique to UIC groups, and the operating system uses the UIC group number of the calling process to interpret the process name specified by the *prcnam* argument. You must use the *pidadr* argument to delete processes in other UIC groups.

Description

The Resume Process service (1) causes a process previously suspended by the Suspend Process (\$SUSPND) service to resume execution or (2) cancels the effect of a subsequent suspend request.

If you specify neither the *pidadr* nor *prcnam* argument, the resume request is issued on behalf of the calling process.

If the longword value at address *pidadr* is 0, the PID of the target process is returned.

If one or more resume requests are issued for a process that is not suspended, a subsequent suspend request completes immediately; that is, the process is not suspended. No count of outstanding resume requests is maintained.

Required Access or Privileges

Depending on the operation, the calling process might need one of the following privileges to use \$RESUME:

- GROUP privilege to resume execution of a process in the same group unless the process has the same UIC as the calling process
- WORLD privilege to resume execution of any process in the system

Required Quota

None

Related Services

\$SCANEXH, \$CREPRC, \$DCLEXH, \$DELPRC, \$EXIT, \$FORCEX, \$GETJPI, \$GETJPIW, \$HIBER, \$PROCESS_SCAN, \$SETPRI, \$SETPRN, \$SETPRV, \$SETRWM, \$SUSPND, \$WAKE

Condition Values Returned

SS\$_NORMAL

The service completed successfully.

SS\$_ACCVIO

The process name string or string descriptor cannot be read by the caller, or the process identification cannot be written by the caller.

SS\$_INCOMPAT

The remote node is running an incompatible version of the operating system.

SS\$_IVLOGNAM

The specified process name has a length of 0 or has more than 15 characters.

SS\$_NONEXPR

The specified process does not exist, or an invalid process identification was specified.

SS\$_NOPRIV

The process does not have the privilege to resume the execution of the specified process.

SS\$_NOSUCHNODE

The process name refers to a node that is not currently recognized as part of the cluster.

SS\$_REMRSRC

The remote node has insufficient resources to respond to the request. (Bring this error to the attention of your system manager.)

SS\$_UNREACHABLE

The remote node is a member of the cluster but is not accepting requests. (This is normal for a brief period early in the system boot process.)

\$REVOKID

Revoke Identifier from Process — Removes the specified identifier from the rights list of the process or the system. If the identifier is listed as a holder of any other identifier, the appropriate holder records are also deleted.

Format

```
SYS$REVOKID
    [pidadr] , [prcnam] , [id] , [name] , [prvatr]
```

C Prototype

```
int sys$revokid
    (unsigned int *pidadr, void *prcnam, struct _generic_64 *id, void *name,
     unsigned int *prvatr, unsigned int segment);
```

Arguments

pidadr

OpenVMS usage: process_id
type: longword (unsigned)

access: modify
mechanism: by reference

Process identification (PID) number of the process affected when \$REVOKID completes execution. The *pidadr* argument is the address of a longword containing the PID of the process to be affected. You use `-1` to indicate the system rights list. When *pidadr* is passed, it is also returned; therefore, you must pass it as a variable rather than a constant.

prcnam

OpenVMS usage: process_name
type: character-coded text string
access: read only
mechanism: by descriptor–fixed-length string descriptor

Process name on which \$REVOKID operates. The *prcnam* argument is the address of a character string descriptor containing the process name. The maximum length of the name is 15 characters. Because the UIC group number is interpreted as part of the process name, you must use *pidadr* to specify the rights list of a process in a different group.

id

OpenVMS usage: rights_id
type: quadword (unsigned)
access: modify
mechanism: by reference

Identifier and attributes to be removed when \$REVOKID completes execution. The *id* argument is the address of a quadword containing the binary identifier code to be removed in the first longword and the attributes in the second longword.

Symbol values are offsets to the bits within the longword. You can also obtain the values as masks with the appropriate bit set using the prefix `KGB$M` rather than `KGB$V`. The following symbols for each bit position are defined in the system macro library (`$KGBDEF`).

Bit Position	Meaning When Set
<code>KGB\$V_DYNAMIC</code>	Allows unprivileged holders of the identifier to remove it from or add it to the process rights database by using the DCL command <code>SET RIGHTS_LIST</code> .
<code>KGB\$V_NOACCESS</code>	Makes any access rights of the identifier null and void. This attribute is intended as a modifier for a resource identifier or the Subsystem attribute.
<code>KGB\$V_RESOURCE</code>	Allows holders of an identifier to charge disk space to the identifier. It is used only for file objects.
<code>KGB\$V_SUBSYSTEM</code>	Allows holders of the identifier to create and maintain protected subsystems by assigning the Subsystem ACE to the application images in the subsystem.

You must specify either *id* or *name*. Because the *id* argument is returned as well as passed if you specify *name*, you must pass it as a variable rather than a constant in this case.

name

OpenVMS usage: char_string

type: character-coded text string
 access: read only
 mechanism: by descriptor–fixed-length string descriptor

Name of the identifier removed when \$REVOKID completes execution. The *name* argument is the address of a descriptor pointing to the name of the identifier.

prvatr

OpenVMS usage: mask_longword
 type: longword (unsigned)
 access: write only
 mechanism: by reference

Attributes of the deleted identifier. The *prvatr* argument is the address of a longword used to store the attributes of the identifier.

Description

The Revoke Identifier from Process service removes the specified identifier from the rights list of the process or the system. If the identifier is listed as a holder of any other identifier, the appropriate holder records are also deleted.

The result of passing the *pidadr* or the *prcnam* argument, or both, to \$REVOKID is summarized in the following table.

Note that a value of 0 in either of the following tables indicates that the contents of the address specified by the argument is the value 0. The word *omitted* indicates that the argument was not supplied.

prcnam	pidadr	Result
Omitted	Omitted	Current process ID is used; process ID is not returned.
Omitted	0	Current process ID is used; process ID is returned.
Omitted	Specified	Specified process ID is used.
Specified	Omitted	Specified process name is used; process ID is not returned.
Specified	0	Specified process name is used; process ID is returned.
Specified	Specified	Specified process ID is used and process name is ignored.

The result of passing either the *name* or the *id* argument, or both, to SYS\$REVOKID is summarized in the following table.

name	id	Result
Omitted	Omitted	Illegal. The INSFARG condition value is returned.
Omitted	Specified	Specified identifier value is used.
Specified	Omitted	Specified identifier name is used; identifier value is not returned.
Specified	0	Specified identifier name is used; identifier value is returned.
Specified	Specified	Specified identifier value is used and identifier name is ignored.

Because the Revoke Identifier from Process service removes the specified identifier from the rights list of the process or the system, this service is meant for use by a privileged subsystem to alter the access rights profile of a user, based on installation policy. It is not meant for use by the general system user.

Required Access or Privileges

You need CMKRNL privilege to invoke this service. In addition, you need GROUP privilege to modify the rights list of a process in the same group as the calling process (unless the process has the same UIC as the calling process). You need WORLD privilege to modify the rights list of a process outside the caller's group. You need SYSNAM privilege to modify the system rights list.

Required Quota

None

Related Services

\$ADD HOLDER, \$ADD_IDENT, \$ASCTOID, \$CREATE_RDB, \$FIND_HELD, \$FIND HOLDER, \$FINISH_RDB, \$GRANTID, \$IDTOASC, \$MOD HOLDER, \$MOD_IDENT, \$REM HOLDER, \$REM_IDENT

Condition Values Returned

SS\$_WASCLR

The service completed successfully; the rights list did not contain the specified identifier.

SS\$_WASSET

The service completed successfully; the rights list already held the specified identifier.

SS\$_ACCVIO

The *pidadr* argument cannot be read or written; *prcnam* cannot be read; *id* cannot be read or written; *name* cannot be read; or *prvatr* cannot be written.

SS\$_INSFARG

You did not specify either the *id* or the *name* argument.

SS\$_INSFMEM

The process dynamic memory is insufficient for opening the rights database.

SS\$_IIDENT

The specified identifier name is invalid; the identifier name is longer than 31 characters, contains an illegal character, or does not contain at least one nonnumeric character.

SS\$_IVLOGNAM

You specified an invalid process name.

SS\$_NONEXPR

You specified a nonexistent process.

SS\$_NOPRIV

The caller does not have CMKRNL privilege or is not running in executive or kernel mode; or the caller lacks GROUP, WORLD, or SYSNAM privilege as required.

SS\$_NOSUCHID

The specified identifier name does not exist in the rights database. Note that the binary identifier, if given, is not validated against the rights database.

SS\$_NOSYSNAM

The operation requires SYSNAM privilege.

SS\$_RIGHTSFULL

The rights list of the process or system is full.

RMS\$_PRV

The user does not have read access to the rights database.

Because the rights database is an indexed file accessed with OpenVMS RMS, this service can also return RMS status codes associated with operations on indexed files. For descriptions of these status codes, refer to the *VSI OpenVMS Record Management Services Reference Manual*.

\$REWIND

Sets to First Record — The Rewind service sets the context of a record stream to the first record in the file. RMS alters the context of the next record to indicate the first record as being the next record. For additional information about this service, see the *VSI OpenVMS Record Management Services Reference Manual*.

\$RMSRUNDWN

RMS Rundown — Closes all files opened by OpenVMS RMS for the image or process and halts I/O activity. This routine performs a \$CLOSE service for each file opened for processing.

Format

```
SYS$RMSRUNDWN buf-addr ,type-value
```

C Prototype

```
int sys$rmsrundwn ( void *buf-addr, unsigned char *type-value);
```

Arguments

buf-addr

OpenVMS usage: char_string

type: character-coded text string
access: write only
mechanism: by descriptor

A descriptor pointing to a 22-byte buffer that is to receive the device identification (16 bytes) and the file identification (6 bytes) of an improperly closed output file. The *buf-addr* argument is the address of the descriptor that points to the buffer.

type-value

OpenVMS usage: byte_unsigned
type: byte (unsigned)
access: read only
mechanism: by value

A single byte code that specifies the type of I/O rundown to be performed. The *type-value* argument is the actual value used.

This type of code has the following values and meanings:

0	Rundown of image and indirect I/O for process permanent files.
1	Rundown of image and process permanent files. The caller's mode must not be user.
2	Abort RMS I/O. The caller's mode must be either executive or kernel (the system calls the I/O rundown control routine with this argument for process deletion).

Description

The RMS Rundown service closes all files opened by OpenVMS RMS for the image or process and halts I/O activity. This routine performs a \$CLOSE service for each file opened for processing. In addition to closing all files and terminating I/O activity, the I/O rundown control routine releases all locks held on records in shared files, clears buffers, and returns other resources allocated for file processing. You should continue to call the rundown control routine until you receive the success completion status code of RMS\$_NORMAL.

Note that, prior to the execution of the \$CLOSE service, the rundown control routine cancels all outstanding file operations specified in a File Access Block (FAB) or any QIO requests related to file operations (an Open, Create, or Extend service, for example). It also cancels any read/write requests to nondisk devices such as terminals or mailboxes prior to the execution of the \$CLOSE service, resulting in possible loss of data. All read/write requests of disk I/O buffers, however, are allowed to complete, which guarantees that none of the data written to disk files will be lost.

There is no predefined macro of the form \$RMSRUNDWN_G or \$RMSRUNDWN_S to call this service.

Required Access or Privileges

None

Required Quota

None

Related Services

\$ALLOC, \$ASSIGN, \$BRKTHRU, \$BRKTHRUW, \$CANCEL, \$CLOSE, \$CREMBX, \$DALLOC, \$DASSGN, \$DELMBX, \$DEVICE_SCAN, \$DISMOU, \$GETDVI, \$GETDVIW, \$GETMSG, \$GETQUI, \$GETQUIW, \$INIT_VOL, \$MOUNT, \$PUTMSG, \$QIO, \$QIOW, \$SETDDIR, \$SETDFPROT, \$SNDERR, \$SNDJBC, \$SNDJBCW, \$SNDOPR

Condition Values Returned

RMS\$_NORMAL

The service completed successfully.

RMS\$_CCF

The I/O rundown routine cannot close the file.

RMS\$_IAL

The argument list is invalid. An output file could not be closed successfully, and the user buffer could not be written.

\$RPCC_64 (Alpha and Integrity servers)

Read 64-Bit Process Cycle Counter — On Alpha and Integrity server systems, returns a 64-bit, process-based, high-resolution time counter.

Format

`SYS$RPCC_64`

C Prototype

```
uint64 sys$rpcc_64 ();
```

Description

On Alpha and Integrity server systems, returns a 64-bit long version of the current process cycle counter.

On Alpha systems, this service must be called at least once within each wrap period of the least significant 32 bits of the counter.

For more information, see the `RPCC()` C-language built-in documentation and the `RPCC` instruction in the *Alpha Architecture Handbook*.

Required Access or Privileges

None

Required Quota

None

SSCAN_INTRUSION

Scan Intrusion Database — Scans the intrusion database for suspects or intruders during a login attempt, audits login failures and updates records, or adds new records to the intrusion database.

Format

```
SYSSSCAN_INTRUSION
    logfail_status , failed_user , job_type , [source_terminal]
    , [source_node] , [source_user] , [source_addr] , [failed_password]
    , [parent_user] , [parent_id] , [flags]
```

C Prototype

```
int sys$scan_intrusion
    (unsigned int logfail_status, void *failed_user, unsigned int job_type,
    void *source_terminal, void *source_node, void *source_user,
    void *source_address, void *failed_password, void *parent_user,
    unsigned int parent_id, unsigned int flags);
```

Arguments

logfail_status

OpenVMS usage: status code
type: longword (unsigned)
access: read only
mechanism: by value

Reason why the user's login attempt failed. The *logfail_status* argument is a longword containing the login failure status code.

The *logfail_status* argument can contain any valid message code. For example, the value of the *logfail_status* argument is SS\$_NOSUCHUSER if the user name the user entered does not exist on the system.

If the *logfail_status* argument contains a failure status, the service performs a suspect scan. Here, the service searches the intrusion database for intruder suspects as well as intruders. If the value of the *logfail_status* argument is a successful message, such as SS\$_NORMAL, the service scans the database only for intruders. For more information about how the database works, see the *VSI OpenVMS Guide to System Security*.

failed_user

OpenVMS usage: char_string or item_list_3
type: character-coded text string or longword (unsigned)
access: read only
mechanism: by descriptor–fixed-length string descriptor or by reference

If the CIA\$M_ITEMLIST flag is FALSE:

This argument is the user name associated with the unsuccessful login attempt. The *failed_user* argument is the address of a character-string descriptor pointing to the failed user name.

A failed user name consists of 1 to 32 alphanumeric characters.

If the CIA\$M_ITEMLIST flag is TRUE:

The *failed_user* argument is the address of a 32-bit item list. If the item list is used, one item, the CIA\$_FAILED_USERNAME item, must be present in the item list.

The following table lists the valid item descriptions for the *failed_user* argument:

Item	Description
CIA\$_FAILED_USERNAME	Address of a buffer containing the failed user name.
CIA\$_SCSNODE	Address of the 8-character null-padded SCS node name on which the intrusion happened.
CIA\$_USER_DATA	Address of a 256-byte buffer, available for passing third party specified data.

job_type

OpenVMS usage: job type
type: longword (unsigned)
access: read only
mechanism: by value

Type of job that failed. The *job_type* argument is a longword indicating the type of job that failed.

The \$JPIDEF macro defines the following values for the *job_type* argument:

- JPI\$K_BATCH
- JPI\$K_DETACHED
- JPI\$K_DIALUP
- JPI\$K_LOCAL
- JPI\$K_NETWORK
- JPI\$K_REMOTE

source_terminal

OpenVMS usage: char_string
type: character-coded text string
access: read only
mechanism: by descriptor–fixed-length string descriptor

Source terminal where the login attempt is occurring. The *source_terminal* argument is the address of a character-string descriptor pointing to the device name of the terminal from which the login attempt originates.

A source terminal device name consists of 1 to 64 alphanumeric characters, including underscores (_) and colons (:).

source_node

OpenVMS usage: char_string
type: character-coded text string
access: read only
mechanism: by descriptor–fixed-length string descriptor

Name of the node from which the user's login attempt originates. The *source_node* argument is the address of a character-string descriptor pointing to the source node name string.

A source node name consists of 1 to 1024 characters. No specific characters, format, or case is required for a source node name string.

source_user

OpenVMS usage: char_string
type: character-coded text string
access: read only
mechanism: by descriptor–fixed-length string descriptor

User name associated with the login attempt. The *source_user* argument is the address of a character-string descriptor pointing to the source user name string.

A source user name consists of 1 to 32 alphanumeric characters, including dollar signs (\$) and underscores (_).

source_addr

OpenVMS usage: node address
type: descriptor
access: read only
mechanism: by reference

Source DECnet for OpenVMS address from which the login attempt originates. The *source_addr* argument is the address of a descriptor containing the source node address.

failed_password

OpenVMS usage: char_string
type: character-coded text string
access: read only
mechanism: by descriptor–fixed-length string descriptor

Password the user entered for the login attempt. The *failed_password* argument is the address of a character-string descriptor pointing to the plaintext password the user entered to log in.

A failed password is a password of 0 to 32 characters that did not allow the user to log in to the system. This argument is not stored in the intrusion database and is only used for auditing during break-in attempts.

parent_user

OpenVMS usage: char_string
 type: character-coded text string
 access: read only
 mechanism: by descriptor-fixed-length string descriptor

Parent process name of the failed login. The *parent_user* argument is the address of a character-string descriptor pointing to the parent process name of the failed login process.

A parent process name consists of 1 to 15 characters. This argument should be specified only for failed spawn commands.

parent_id

OpenVMS usage: process_id
 type: longword (unsigned)
 access: read only
 mechanism: by value

Process identification of the parent process from which the login was attempted. The *parent_id* argument is a longword containing the parent process identification.

flags

OpenVMS usage: mask_longword
 type: longword (unsigned)
 access: read only
 mechanism: by value

Operational instructions for the service. The *flags* argument is a longword bit mask wherein each bit corresponds to an option.

Each flag option has a symbolic name. The \$CIADEF macro defines the following valid names for the \$SCAN_INTRUSION service.

Symbolic Name	Description
CIA\$M_NOAUDIT	If set, this flag indicates that the service should instruct the security server to not audit the login failure or the break-in attempt. If the flag is set, you are expected to do your own auditing.
CIA\$M_IGNORE_RETURN	Specifies that the service should not wait for the return status from the security server. No return status from the server's function will be returned to the caller.
CIA\$M_ITEMLIST	If FALSE, the <i>failed_user</i> argument is a character string. If TRUE, this argument is a 32-bit item list.
CIA\$M_REAL_USERNAME	If set, indicates that the user name passed as the failed user name is read and known to the system.

Symbolic Name	Description
CIA\$M_SECONDARY_PASSWORD	Indicates that the failed password passed to the service was the secondary password. If the flag is clear, the password is assumed to be the primary password.

Description

The Scan Intrusion service performs the following functions:

- Scans the intrusion database for intruders so that successful logins are evaded if the system is taking evasive action.
- Adds login failures to the intrusion database.
- Changes records in the intrusion database from suspects to intruders when the number of login failures by the specified user or from the specified source reaches the value of the LGI_BREAK_LIM system parameter.
- Disables user accounts if the LGI_BRK_DISUSER flag is set and the number of login attempts on a real user has reached LGI_BRK_LIM.
- Audits login failures or break-in attempts on behalf of the caller.

The information that \$SCAN_INTRUSION stores in the intrusion database is based on the setting of the LGI_BRK_TERM system parameter and the information passed by the caller. For more information about how the intrusion database functions and the use of the LGI system parameters, see the *VSI OpenVMS Guide to System Security*.

Required Access or Privileges

\$SCAN_INTRUSION requires the SECURITY privilege.

Required Quota

None

Related Services

\$DELETE_INTRUSION, \$SHOW_INTRUSION

Condition Values Returned

SS\$_NORMAL

The service completed successfully.

SS\$_ACCVIO

One or more of the arguments were not readable.

SS\$_BADBUFLN

The length of one or more of the specified arguments is out of range.

SS\$_BADPARAM

An invalid flag was specified in the *flags* argument.

SS\$_NOSECURITY

The caller does not have SECURITY privilege.

This service can also return any of the following messages passed from the security server:

SECSRV\$_INSUFINFO

Not enough information is supplied to form an intrusion record.

SECSRV\$_INTRUDER

An intruder matching the information passed to the service exists in the intrusion database.

SECSRV\$_NOMATCH

No intruders or suspects exist that match the information passed to the service.

SECSRV\$_SERVERNOTACTIVE

The security server is not currently active. Try the request again later.

SECSRV\$_SUSPECT

A suspect matching the information passed to the service exists in the intrusion database.

\$SCHDWK

Schedule Wakeup — Schedules the awakening (restarting) of a process that has placed itself in a state of hibernation with the Hibernate (\$HIBER) service.

Format

```
SYS$SCHDWK [pidadr] , [prcnam] , daytim , [reptim]
```

C Prototype

```
int sys$schdwk
(unsigned int *pidadr, void *prcnam, struct _generic_64 *daytim,
 struct _generic_64 *reptim);
```

Arguments

pidadr

OpenVMS usage: process_id
type: longword (unsigned)
access: modify
mechanism: by reference

Process identification (PID) of the process to be awakened. The *pidadr* argument is the address of a longword containing the PID. The *pidadr* argument can refer to a process running on the local node or a process running on another node in the OpenVMS Cluster system.

You must specify the *pidadr* argument to awaken processes in other UIC groups.

prcnam

OpenVMS usage: process_name
type: character-coded text string
access: read only
mechanism: by descriptor–fixed length string descriptor

Name of the process to be awakened. The *prcnam* is the address of a character string descriptor pointing to the process name. A process running on the local node can be identified with a string of from 1 to 15 characters.

To identify a process on a particular node on a cluster, specify the full process name, which includes the node name as well as the process name. The full process name can contain up to 23 characters.

You can use the *prcnam* argument to awaken only processes in the same UIC group as the calling process because process names are unique to UIC groups, and the operating system uses the UIC group number of the calling process to interpret the process name specified by the *prcnam* argument. You must use the *pidadr* argument to awaken processes in other UIC groups.

daytim

OpenVMS usage: date_time
type: quadword
access: read only
mechanism: by reference

Time at which the process is to be awakened. The *daytim* argument is the address of a quadword containing this time in the system 64-bit time format. A positive time value specifies an absolute time at which the specified process is to be awakened. A negative time value specifies an offset (delta time) from the current time.

reptim

OpenVMS usage: date_time
type: quadword (unsigned)
access: read only
mechanism: by reference

Time interval at which the wakeup request is to be repeated. The *reptim* argument is the address of a quadword containing this time interval. The time interval must be expressed in delta time format.

The time interval specified cannot be less than 10 milliseconds; if it is, \$SCHDWK automatically increases it to 10 milliseconds.

If you do not specify *reptim*, a default value of 0 is used, which specifies that the wakeup request is not to be repeated.

Description

The Schedule Wakeup service schedules the awakening of a process that has placed itself in a state of hibernation with the Hibernate (\$HIBER) service. A wakeup can be scheduled for a specified absolute time or for a delta time and can be repeated at fixed intervals.

If you specify neither the *pidadr* nor the *prcnam* argument, the wakeup request is issued on behalf of the calling process. If the longword value at address *pidadr* is 0, the PID of the target process is returned.

\$SCHDWK uses the system dynamic memory to allocate a timer queue entry.

If you issue one or more scheduled wakeup requests for a process that is not hibernating, a subsequent hibernate request by the target process completes immediately; that is, the process does not hibernate. No count of outstanding wakeup requests is maintained.

You can cancel scheduled wakeup requests that have not yet been processed by using the Cancel Wakeup (\$CANWAK) service.

If a specified absolute time value has already passed and no repeat time is specified, the timer expires at the next clock cycle (within 10 milliseconds).

Required Access or Privileges

Depending on the operation, the calling process might need one of the following privileges to use \$SCHDWK:

- GROUP privilege to schedule wakeup requests for a process in the same group unless it has the same UIC
- WORLD privilege to schedule wakeup requests for any other process in the system

Required Quota

This service uses the process's timer queue entries (TQELM) quota. If you specify an AST routine, the service uses the AST limit (ASTLM) quota of the calling process to schedule a wakeup request.

Related Services

\$ASCTIM, \$BINTIM, \$CANTIM, \$CANWAK, \$GETTIM, \$NUMTIM, \$SETIME, \$SETIMR

Condition Values Returned

SS\$_NORMAL

The service completed successfully.

SS\$_ACCVIO

The expiration time, repeat time, process name string, or string descriptor cannot be read by the caller, or the process identification cannot be written by the caller.

SS\$_EXQUOTA

The process has exceeded its AST limit quota.

SS\$_INCOMPAT

The remote node is running an incompatible version of the operating system.

SS\$_INSFMEM

The system dynamic memory is insufficient for allocating a timer queue entry.

SS\$_IVLOGNAM

The process name string has a length of 0 or has more than 15 characters.

SS\$_IVTIME

The specified delta repeat time is a positive value, or an absolute time plus delta repeat time is less than the current time.

SS\$_NONEXPR

The specified process does not exist, or an invalid process identification was specified.

SS\$_NOPRIV

The process does not have the privilege to schedule a wakeup request for the specified process.

SS\$_NOSUCHNODE

The process name refers to a node that is not currently recognized as part of the OpenVMS Cluster system.

SS\$_REMRSRC

The remote node has insufficient resources to respond to the request. (Bring this error to the attention of your system manager.)

SS\$_UNREACHABLE

The remote node is a member of the cluster but is not accepting requests. (This is normal for a brief period early in the system boot process.)

\$SCHED

Affect Process Scheduling — Affects process scheduling. This service is intended for use by a class scheduler process.

Format

```
SYS$SCHED func ,p1 ,p2 ,p3
```

C Prototype

```
int sys$sched
(unsigned int func, unsigned int *p1, unsigned int *p2,
 unsigned int *p3);
```

Arguments

func

OpenVMS usage: function_code
 type: longword (unsigned)
 access: write only
 mechanism: by value

Function code specifying the action \$SCHD is to perform. The *func* argument is a longword containing this code.

See the Function Codes section for a list of valid function codes for \$SCHD.

p1, p2, p3

OpenVMS usage: longword
 type: longword (unsigned)
 access: varies
 mechanism: varies

The meaning of the *p1*, *p2*, and *p3* arguments depends on the function code specified in the *func* argument, and is defined in the Function Codes section.

Function Codes

This section defines each of the \$SCHD function codes and describes the values of the *p1* argument, *p2* argument, and *p3* argument for each function.

CSH\$_READ_ALL

When you specify CSH\$_READ_ALL, \$SCHD returns a buffer containing information, including an index, EPID, and priority, for all processes.

The format of the buffer is defined in the \$CSHDEF macro and consists of a series of CSHP fields.

The following table shows the *p1* argument, *p2* argument, and *p3* argument values for the CSH\$_READ_ALL function code.

Argument	Access	Description
<i>p1</i>	Read	Address of the buffer.
<i>p2</i>	Write	Address of the longword size of the buffer.
<i>p3</i>	Write	Address of the longword size of the per-process entry.

CSH\$_READ_NEW

When you specify CSH\$_READ_NEW, \$SCHD returns a buffer containing information, including an index, EPID, and priority, for all processes for which a class assignment has not been made.

The format of the buffer is defined in the \$CSHDEF macro and consists of a series of CSHP fields.

The following table shows the *p1* argument, *p2* argument, and *p3* argument values for the CSH\$_READ_NEW function code.

Argument	Access	Description
<i>p1</i>	Read	Address of the buffer.
<i>p2</i>	Write	Address of the longword size of the buffer.
<i>p3</i>	Write	Address of the longword size of the per-process entry.

The following table describes the information returned in the buffer fields for both CSH\$_READ_ALL and CSH\$_READ_NEW.

Buffer Field	Definition
CSHP\$_ACCOUNT	Account string from the user authorization file (first eight characters).
CSHP\$_CPUTIM	Process CPU time used, in 10-millisecond ticks.
CSHP\$_EPID	Process ID (PID). If CSHP information is insufficient to determine the right class for a process, the PID can be used with the \$GETJPI(W) system service to obtain additional detail.
CSHP\$_PIX	A unique integer assigned to the process for its duration. Applications might want to use this value to index arrays.
CSHP\$_PRI	Current process priority.
CSHP\$_PRIB	Base process priority.
CSHP\$_STATUS	Undefined; reserved to OpenVMS.

CSH\$_READ_QUANT

When you specify CSH\$_READ_QUANT, \$SCHED returns a buffer containing information about how many ticks are left for each class. Data is returned in a series of longwords, one longword per class, starting with class number 0.

The following table defines the *p1* argument, *p2* argument, and *p3* argument values when specifying the CSH\$_READ_QUANT function code.

Argument	Access	Description
<i>p1</i>	Read	Address of the buffer.
<i>p2</i>	Read	Address of the longword size of the buffer.
<i>p3</i>	—	Unused.

CSH\$_SET_ATTN_AST

Enables attention asynchronous system traps (ASTs).

The following table defines the *p1* argument, *p2* argument, and *p3* argument values when specifying the CSH\$_SET_ATTN_AST function code.

Argument	Access	Description
<i>p1</i>	Read	Address of an AST routine.
<i>p2</i>	Read	Access mode to deliver AST.
<i>p3</i>	—	Unused.

CSH\$_SET_CLASS

Places processes in classes with or without windfall capability. The caller supplies a buffer consisting of CSHC blocks.

The format of the buffer is defined in the \$CSHDEF macro. The following table describes the information contained in the buffer.

Buffer Field	Definition
CSHC\$L_EPID	Process ID (PID) of the process to affect.
CSHC\$W_CLASS	Class into which to place the process. Class 65535 (hexadecimal FFFF) has a special interpretation: the associated process is not to be class scheduled and will, therefore, never run out of class quantum. The largest class number is 8191.
CSHC\$W_WINDFALL	Determines whether the process is to share windfall. A value of 1 permits the process to share windfall; a value of 0 prevents the process from sharing windfall. Values other than 0 and 1 are undefined and can cause unpredictable behavior in future releases of the operating system.

The following table defines the *p1* argument, *p2* argument, and *p3* argument values when specifying the CSH\$_SET_CLASS function code.

Argument	Access	Description
<i>p1</i>	Read	Address of the buffer.
<i>p2</i>	Read	Address of the longword size of the buffer.
<i>p3</i>	Read	Address of the longword size of the entry used. Should be CSHC\$K_LENGTH or equivalent.

CSH\$_SET_NEW

Indicates to the class scheduler that the next READ_NEW will return information about the calling process. This function should be used only in executive or kernel mode.

The following table defines the *p1* argument, *p2* argument, and *p3* argument values when specifying the CSH\$_SET_NEW function code.

Argument	Access	Description
<i>p1</i>	—	Unused.
<i>p2</i>	Read	PID (by value).
<i>p3</i>	—	Unused.

CSH\$_SET_QUANT

Establishes class quantum and enables class scheduling. The caller supplies a buffer that allocates CPU ticks to classes, one longword per class, starting with class number 0. Class-scheduled processes will have their quantum deducted from the appropriate longword, and will be removed from execution if class quantum is decremented to 0.

The following table defines the *p1* argument, *p2* argument, and *p3* argument values when specifying the CSH\$_SET_QUANT function code.

Argument	Access	Description
<i>p1</i>	Read	Address of the buffer.
<i>p2</i>	Read	Address of the longword size of buffer.
<i>p3</i>	—	Unused.

CSH\$_SET_TIMEOUT

Establishes a nonstandard timeout. If the application does not issue a CSH\$_SET_QUANT within the timeout period, all class scheduling is stopped and processes are returned to normal scheduling. The default value, 30 seconds, should be suitable for most circumstances.

The following table defines the *p1* argument, *p2* argument, and *p3* argument values when specifying the CSH\$_SET_TIMEOUT function code.

Argument	Access	Description
<i>p1</i>	—	Unused.
<i>p2</i>	Read	Time in seconds (by value).
<i>p3</i>	—	Unused.

Description

The Affect Process Scheduling service is used by class scheduler processes to affect scheduling.

Use the *func* argument to specify which action \$SCHED is to perform.

Required Access or Privileges

ALTPRI is required to affect processes. Group access is required to affect processes in the same UIC group. World access is required to affect processes in different UIC groups. SYSPRV is required to set the timeout value.

Required Quota

None

Related Services

\$GETJPI, \$GETJPIW, \$SETPRI

Condition Values Returned

SS\$_NORMAL

Service completed successfully.

SS\$_ACCVIO

Buffer, length, or size locations not writeable.

SS\$_BADPARAM

Specified a class higher than currently defined, or an element size of 0 was specified.

SS\$_BUFFEROVF

Buffer is too small, only some data transferred.

SS\$_INCLASS

Returned if a process (specified by the input PID) already belongs to a scheduling class. This can happen if the process was previously class scheduled at login through the class scheduler permanent database file, or by issuing the command, SET PROCESS/SCHEDULING_CLASS="class_name".

SS\$_INSFMEM

System dynamic memory is insufficient to complete the service.

SS\$_NOSUCHUSER

Supplied PID is not valid.

\$SEARCH

Scans Directory File — The Search service scans a directory file and fills in various NAM block fields. This service should be preceded by the Parse service, in order to initialize the NAM block appropriately. For additional information about this service, see the *VSI OpenVMS Record Management Services Reference Manual*.

\$SETAST

Set AST Enable — Enables or disables the delivery of asynchronous system traps (ASTs) for the access mode from which the service call was issued.

Format

```
SYS$SETAST enbflg
```

C Prototype

```
int sys$setast (char enbflg);
```

Argument

enbflg

OpenVMS usage:	boolean
type:	byte (unsigned)
access:	read only
mechanism:	by value

Value specifying whether ASTs are to be enabled. The *enbflg* argument is a byte containing this value. The value 1 enables AST delivery for the calling access mode; the value 0 disables AST delivery.

Description

The Set AST Enable service enables or disables the delivery of ASTs for the access mode from which the service call was issued.

Required Access or Privileges

When an image is executing in user mode, ASTs are always enabled for more privileged access modes. If ASTs are disabled for a more privileged access mode, the operating system cannot deliver ASTs for less privileged access modes until ASTs are enabled once again for the more privileged access mode. Therefore, a process that has disabled ASTs for a more privileged access mode must reenables ASTs for that mode before returning to a less privileged access mode.

Required Quota

None

Related Services

\$DCLAST, \$SETPRA

Condition Values Returned

SS\$_WASCLR

The service completed successfully. AST delivery was previously disabled for the calling access mode.

SS\$_WASSET

The service completed successfully. AST delivery was previously enabled for the calling access mode.

\$SETCLUEVT

Set Cluster Event — Establishes a request for notification when an OpenVMS Cluster configuration event occurs.

Format

```
SYS$SETCLUEVT event ,astadr ,[astprm] ,[acmode] ,[handle]
```

C Prototype

```
int sys$setcluevt
(unsigned int event, void (*astadr)(__unknown_params), int astprm,
 unsigned int acmode, struct _generic_64 *handle);
```

Arguments

event

OpenVMS usage: event_code
 type: longword (unsigned)
 access: read only
 mechanism: by value

Event code indicating the type of cluster configuration event for which an AST is to be delivered. The *event* argument is a value indicating which type of event is of interest.

Each event type has a symbolic name. The \$CLUEVTDEF macro defines the following symbolic names.

Symbolic Name	Description
CLUEVT\$C_ADD	One or more OpenVMS nodes have been added to the OpenVMS Cluster system.
CLUEVT\$C_REMOVE	One or more OpenVMS nodes have been removed from the OpenVMS Cluster system.

astadr

OpenVMS usage: ast_procedure
 type: procedure value
 access: call without stack unwinding
 mechanism: by reference

Notification AST routine to receive control after a change in OpenVMS Cluster configuration occurs.

astprm

OpenVMS usage: user_arg
 type: longword (unsigned)
 access: read only
 mechanism: by value

Optional AST parameter to be passed to the AST service routine. The *astprm* argument is a longword value containing the AST parameter.

acmode

OpenVMS usage: access_mode
 type: longword (unsigned)
 access: read only
 mechanism: by value

Optional access mode at which the configuration event AST is to execute. The *acmode* argument is a longword containing the access mode.

Each access mode has a symbolic name. The \$PSLDEF macro defines the following symbols for the four access modes.

Symbol	Access Mode
PSL\$C_KERNEL	Kernel

Symbol	Access Mode
PSL\$C_EXEC	Executive
PSL\$C_SUPER	Supervisor
PSL\$C_USER	User

The value of the access mode must not be more privileged than the access mode of the caller.

handle

OpenVMS usage: identifier
type: quadword (unsigned)
access: write only
mechanism: by reference

Optional identifier to receive a value that uniquely identifies this AST request. \$SETCLUEVT sets this handle to a unique value so that it can later be used to identify the request in the \$CLRCLUEVT and \$TSTCLUEVT services.

Description

The Set Cluster Event service establishes a request for notification when a cluster configuration event occurs. The service establishes only one AST notification for a configuration event. To receive AST notification for all cluster configuration events, the \$SETCLUEVT service must be reissued within the notification AST routine. The service will verify that the input parameters specify a valid request, allocate appropriate data structures to hold the request, and enqueue the request for notification.

You must specify an event type and an AST address. You can specify an AST parameter, the access mode, and an address into which to place the handle of this request.

Errors will be returned in the following cases:

- If quotas are exceeded, an error identifying the specific quota will be returned. It is important to note that this routine will return an error and will not retry an attempt to get quota if quota is exhausted on the first attempt. See the Condition Values Returned section for types of errors that can be returned.
- If the *astadr* argument is omitted, SS\$_BADPARAM will be returned.
- If the *event* argument is omitted or incorrectly specified, SS\$_BADPARAM will be returned.
- If the access mode parameter is more privileged than the mode of the caller, the mode of the caller will be used.
- If specified, the *handle* argument must be readable and writable from the mode of the caller. SS\$_ACCVIO is returned if this is not the case.

Required Access or Privileges

None

Required Quota

None

Related Services

\$CLRCLUEVT, \$STSTCLUEVT

Condition Values Returned

SS\$_NORMAL

The service completed successfully.

SS\$_ACCVIO

Unable to process parameters for improper use.

SS\$_BADPARAM

The event was improperly specified.

SS\$_EXASTLM

The process exceeded its quota for outstanding AST requests.

SS\$_INSFMEM

The system dynamic memory is insufficient to complete the service.

\$SETDDIR

Set Default Directory — Allows you to read and change the default directory string for the process. Do not include any device or file name strings in the default directory string; include only the [DIR] syntax. Modify the device portion of the current default directory location through the specification of the SYS\$DISK logical name. Redefine this logical name using either the \$CRELNM system service or the LIB\$SET_LOGICAL RTL routine.

Format

```
SYS$SETDDIR [new-dir-addr] , [length-addr] , [cur-dir-addr]
```

C Prototype

```
int sys$setddir  
    (void *newdiraddr, unsigned short int *lengthaddr, void *curdiraddr);
```

Arguments

new-dir-addr

OpenVMS usage: char_string
type: character-coded text string
access: read only
mechanism: by descriptor—fixed-length string descriptor

A descriptor of the new default directory. The *new-dir-addr* argument is the address of the descriptor that points to the buffer containing the new directory specification that RMS will use to set the new process-default directory. If the default directory is not to be changed, the value of the *new-dir-addr* argument should be 0.

length-addr

OpenVMS usage: word_unsigned
type: word (unsigned)
access: write only
mechanism: by reference

A word that is to receive the length of the current default directory. The *length-addr* argument is the address of the word that will receive the length. If you do not want this value returned, specify the value 0.

cur-dir-addr

OpenVMS usage: char_string
type: character-coded text string
access: write only
mechanism: by descriptor—fixed-length string descriptor

A descriptor of a buffer that is to receive the current default directory string. The *cur-dir-addr* argument is the address of the descriptor that points to the buffer area that is to receive the current directory string.

Description

The Set Default Directory service allows you to read and change the default directory string for the process. You should restore the previous default directory string to its original state unless you want the changed default directory string to last beyond the exit of your image. The new directory name string is checked for correct syntax.

There is no predefined macro of the form \$SETDDIR_G or \$SETDDIR_S to call this service.

On Alpha and Integrity server systems, the Set Default Directory service attempts to replace the default directory string with a DID abbreviation if the length of the resulting default directory exceeds 255 characters. If this happens, then in addition to the normal syntax check, the entire path to that specification, including the device, is verified and must exist for the call to succeed.

Required Access or Privileges

None

Required Quota

None

Related Services

\$ALLOC, \$ASSIGN, \$BRKTHRU, \$BRKTHRUW, \$CANCEL, \$CREMBX, \$DALLOC, \$DASSGN, \$DELMBX, \$DEVICE_SCAN, \$DISMOU, \$GETDVI, \$GETDVIW, \$GETMSG, \$GETQUI,

\$GETQUIW, \$INIT_VOL, \$MOUNT, \$PUTMSG, \$QIO, \$QIOW, \$SNDERR, \$SNDJBC, \$SNDJBCW, \$SNDOPR

Condition Values Returned

RMS\$_NORMAL

The service completed successfully.

RMS\$_DIR

The directory name contains an error.

RMS\$_IAL

The argument list is invalid.

\$SETDFPROT

Set Default File Protection — Allows you to read and write the default file protection for the process.

Format

```
SYS$SETDFPROT [new-def-prot-addr] , [cur-def-prot-addr]
```

C Prototype

```
int sys$setdfprot
(unsigned short int *newdefprotaddr,
 unsigned short int *curdefprotaddr);
```

Arguments

new-def-prot-addr

OpenVMS usage: file_protection
type: word (unsigned)
access: read only
mechanism: by reference

A word that specifies the new default file protection specification. The *new-def-prot-addr* argument is the address of the word that specifies the desired protection. If you do not want the process-default file protection to be changed, specify the value 0.

cur-def-prot-addr

OpenVMS usage: file_protection
type: word (unsigned)
access: write only

mechanism: by reference

A word that is to receive the current default file protection specification. The *cur-def-prot-addr* argument is the address of the word that receives the current process-default protection. If you do not want the current default file protection, specify the value 0.

Description

The Set Default File Protection service allows you to read and write the default file protection for the process. You should restore the old default file protection specification unless you want the changed default to last beyond the exit of your image.

There is no predefined macro of the form `$SETDEFPROT_G` or `$SETDEFPROT_S` to call this service.

Required Access or Privileges

None

Required Quota

None

Related Services

`$ALLOC`, `$ASSIGN`, `$BRKTHRU`, `$BRKTHRUW`, `$CANCEL`, `$CREMBX`, `$DALLOC`,
`$DASSGN`, `$DELMBX`, `$DEVICE_SCAN`, `$DISMOU`, `$GETDVI`, `$GETDVIW`, `$GETMSG`,
`$GETQUI`, `$GETQUIW`, `$GET_SECURITY`, `$INIT_VOL`, `$MOUNT`, `$PUTMSG`, `$QIO`, `$QIOW`,
`$SET_SECURITY`, `$SNERR`, `$SNDJBC`, `$SNDJBCW`, `$SNDOPR`

Condition Values Returned

`RMS$_NORMAL`

The service completed successfully.

`RMS$_IAL`

The argument list is invalid.

`$SETDTI`

Set Distributed Transaction Information — The Set Distributed Transaction Information service removes resource managers from transactions. It can also be used to modify transaction states.

Format

```
SYS$SETDTI  
    [efn], [flags], iosb, [astadr], [astprm], [contxt], func, itmlst
```

C Prototype

```
int sys$setdti
```



```
(unsigned int efn, unsigned int flags, struct _iosb *iosb,
 void (*astadr)(__unknown_params), int astprm, unsigned int *contxt,
 unsigned short int *func, void *itmlst);
```

Arguments

efn

OpenVMS usage: ef_number
 type: longword (unsigned)
 access: read only
 mechanism: by value

Number of the event flag that is set when the service completes. If this argument is omitted, event flag 0 is used.

flags

OpenVMS usage: mask_longword
 type: longword (unsigned)
 access: read only
 mechanism: by value

Flags specifying options for the service. The *flags* argument is a longword bit mask in which each bit corresponds to an option flag. The \$DDTMDEF macro defines symbolic names for the option flag described in Table 8. All undefined bits must be 0. If this argument is omitted, no flags are used.

Table 8. \$SETDTI Operation Flag

Flag Name	Description
DDTM\$M_SYNC	Specifies successful synchronous completion by returning SS\$_SYNCH. When SS\$_SYNCH is returned, the AST routine is not called, the event flag is not set, and the I/O status block is not filled in.

iosb

OpenVMS usage: io_status_block
 type: quadword (unsigned)
 access: write only
 mechanism: by reference

The I/O status block in which the completion status of the service is returned as a condition value. See the Condition Values Returned section.

The following diagram shows the structure of the I/O status block:

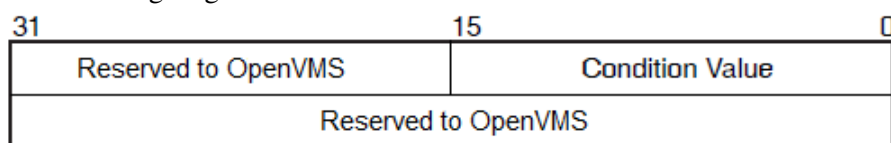

VM-0778A-AI

astadr

OpenVMS usage: ast_procedure
 type: procedure entry mask
 access: call without stack unwinding
 mechanism: by reference

The AST routine executed when the service completes, if SS\$_NORMAL is returned in R0. The *astadr* argument is the address of the entry mask of this routine. The routine is executed in the same access mode as that of the caller of the \$SETDTI service.

astprm

OpenVMS usage: user_arg
 type: longword (unsigned)
 access: read only
 mechanism: by value

The AST parameter passed to the AST routine specified by the *astadr* argument.

contxt

OpenVMS usage: contxt
 type: longword (unsigned)
 access: modify
 mechanism: by reference

Context value obtained from a call to \$GETDTI. It implicitly specifies a node and transaction manager log identifier.

func

OpenVMS usage: function_code
 type: word (unsigned)
 access: read only
 mechanism: by value

Function modifier that specifies the set operation to be performed. The *func* argument is a longword value containing the function code.

Table 9 lists the available function codes:

Table 9. \$SETDTI Function Codes

Function	Description
DTI\$K_DELETE_RM_NAME	Deletes the resource manager specified in <i>itmlst</i> item DTI\$_TRANSACTION_INFORMATION, DTI\$_PART_NAME from the transaction specified by DTI\$_TRANSACTION_INFORMATION, DTI\$_TID.

Function	Description
DTISK_DELETE_TRANSACTION	Deletes the transaction specified by <i>itmlst</i> item DTI\$_TRANSACTION_INFORMATION, DTI\$_TID.
DTISK_MODIFY STATE	Modifies the transaction specified by <i>itmlst</i> item DTI\$_TRANSACTION_INFORMATION, DTI\$_TID, using the transaction state specified in DTI\$_B_STATE.

itmlst

OpenVMS usage: item_list_3
type: longword (unsigned)
access: read only
mechanism: by reference

Item list specifying the transaction information that \$SETDTI is to use. The *itmlst* argument is the address of a list of item descriptors, each of which describes an item of information. The list of item descriptors is terminated by a longword of 0. Each item descriptor in the item list acts as an input argument to \$SETDTI and as such is only required to be read only.

The following diagram depicts the format of a single item descriptor:

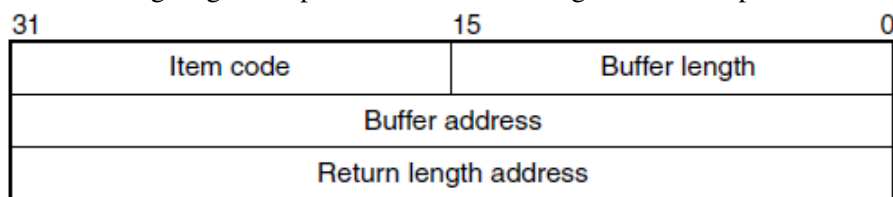

VM-0780A-AI

The following table describes the *itmlst* item descriptor fields:

Field	Description
Buffer length	A word containing a user-supplied integer specifying the length (in bytes) of a buffer from which \$SETDTI is to read the information. The length of the buffer needed depends on the item code specified in the item code field of the item descriptor. If the value of buffer length is too small, \$SETDTI will return an error status.
Item code	A word containing a user-supplied symbolic code specifying the search item that \$SETDTI is to use. The \$DTIDEF macro defines these codes. Each item code is described in the Item Codes section.
Buffer address	A longword containing the user-supplied address of the buffer from which \$SETDTI reads the item information.
Return length address	This longword that is not used in the item list as all items are read-only.

Item Codes

DTI\$_TRANSACTION_INFORMATION

When you specify DTI\$_TRANSACTION_INFORMATION, \$SETDTI uses the fields in the following table to perform the \$SETDTI call. Each function requires a specific set of fields from the transaction

record to perform its operation. If one or more of these fields is not present or valid, then the \$SETDTI call will fail. The fields required by each function are listed in the *func* argument description.

Item	Description
DTI\$B_PART_NAME_LEN	A byte containing the length of the participant name field DTI\$T_PART_NAME.
DTI\$B_STATE	A byte containing the state of the transaction. Two states are valid: DTI\$K_COMMITTED and DTI\$K_ABORTED.
DTI\$T_PART_NAME	A character field containing DTI\$B_PART_NAME_LEN characters that specifies a resource manager name. To ensure smooth operation in a mixed-network environment, refer to the chapter entitled Managing DECdtm Services in the <i>VSI OpenVMS System Manager's Manual</i> , for information on defining node names.
DTI\$T_PART_LOG_ID	Reserved to OpenVMS.
DTI\$T_TID	A 16-byte field containing the transaction identifier.

Description

The \$SETDTI service can be used either to remove resource managers from transactions, or to modify transaction states.

The \$SETDTI service removes resource managers from a single transaction or from all transactions when they no longer have any further interest in a transaction. A call to \$SETDTI typically follows a call to \$GETDTI that established a search context and returned the state of an unresolved transaction.

When a resource manager is recovering from a system failure it will use \$GETDTI to return the state of all unresolved transactions. If the resource manager can recover the transaction, then it needs to be removed from the transaction in the same way it would have been removed had it been able to call \$ACK_EVENT with the forget status before the system failure.

To remove a resource manager, \$SETDTI uses the following fields from the DTI\$_TRANSACTION_INFORMATION item descriptor in the *itmlst* argument:

- Transaction Identifier (TID)
- Resource Manager name
- Resource Manager log identifier

This information, along with the search context, is used to remove the resource manager from the transaction. If the TID field is zero in the DTI\$_TRANSACTION_INFORMATION item descriptor, then the resource manager will be removed from all committed transactions in which it was involved.

When searching for a resource manager, a comparison is made of the leftmost bytes in the transaction manager's log records. This feature enables multiple instances of resource manager classes to be removed from the transaction manager's log after performing a recovery.

The \$SETDTI service can also be used to modify transaction states. It can perform two state transitions: from prepared to committed, or from prepared to aborted. To modify transaction states, \$SETDTI uses the following fields from the DTI\$_TRANSACTION_INFORMATION item descriptor in the *itmlst* argument:

- Transaction Identifier (TID)

- Transaction state

To modify a transaction state, first modify the DTI\$B_STATE field in the DTI\$_TRANSACTION_INFORMATION item descriptor to either DTI\$K_COMMITTED and DTI\$K_ABORTED. Then specify the function code DTI\$K_MODIFY_TRANSACTION to instruct \$SETDTI to perform the state transition.

Note that because DECdtm uses a presumed abort protocol, changing the transaction state to aborted is the same as deleting the transaction.

SYSPRV privilege is required to retrieve or modify information about transactions with which the process is not currently associated.

In most cases, the search context remains valid across multiple calls to \$SETDTI. That is, a call to \$GETDTI may be followed by one or more calls to \$SETDTI without the context becoming invalid. However, the search context is invalidated when a resource manager is deleted from all transactions by specifying a zero TID.

Required Privileges

SYSPRV is required to modify transactions with which the process is not currently associated.

Required Quotas

BYTLM, ASTLM

Related Services

\$ABORT_TRANS, \$ABORT_TRANSW, \$ACK_EVENT, \$ADD_BRANCH, \$ADD_BRANCHW, \$CREATE_UID, \$DECLARE_RM, \$DECLARE_RMW, \$END_BRANCH, \$END_BRANCHW, \$END_TRANS, \$END_TRANSW, \$FORGET_RM, \$FORGET_RMW, \$GETDTI, \$GETDTIW, \$GET_DEFAULT_TRANS, \$JOIN_RM, \$JOIN_RMW, \$SETDTIW, \$SET_DEFAULT_TRANS, \$SET_DEFAULT_TRANSW, \$START_BRANCH, \$START_BRANCHW, \$START_TRANS, \$START_TRANSW, \$TRANS_EVENT, \$TRANS_EVENTW

Condition Values Returned

SS\$_NORMAL

If returned in R0, the request was successfully queued. If returned in the I/O status block, the service completed successfully.

SS\$_SYNCH

The service completed successfully and synchronously (returned only if the DDTM\$M_SYNC flag is set).

SS\$_ACCVIO

An argument was not accessible to the caller.

SS\$_BADLOGVER

There was an invalid or unsupported log version.

SS\$_BADPARAM

Either the options flags were invalid or the *tid* argument was omitted but the *bid* argument was not zero.

SS\$_BADSTATE

There was an invalid transaction state in the ITMLST. Valid states are DTISK_COMMITTED and DTISK_ABORTED.

SS\$_BUGCHECK

A failure has occurred during the processing of the request.

SS\$_EXASTLM

The process AST limit (ASTLM) was exceeded.

SS\$_ILLEFC

The event flag number was invalid.

SS\$_INSFARGS

A required argument was missing.

SS\$_INSFMEM

There was insufficient system dynamic memory for the operation.

SS\$_INVLOG

The log format is invalid.

SS\$_NOSUCHFILE

The transaction manager log cannot be found.

SS\$_NOSUCHNODE

The subordinate DECnet node is unknown.

SS\$_NOSUCHPART

The participant is not part of the transaction.

SS\$_NOSUCHTID

The designated TID is unknown.

SS\$_NOSYSPRV

The caller does not have the SYSPRV privilege.

SS\$_PROTOCOL

There is a message protocol error.

SS\$_REMRSRC

There are insufficient resources at the remote node.

SS\$_UNREACHABLE

A superior node is unreachable.

\$SETDTIW

Set Distributed Transaction Information and Wait — Sets the process current transaction and removes resource managers from transactions. \$SETDTIW\$ always waits for the request to complete before returning to the caller. Other than this, it is identical to \$SETDTI.

Format

```
SYS$SETDTIW
    [efn], [flags], iosb, [astadr], [astprm], [contxt], func, itmlst
```

C Prototype

```
int sys$setdtiw
(unsigned int efn, unsigned int flags, struct _iosb *iosb,
 void (*astadr)(__unknown_params), int astprm, unsigned int *contxt,
 unsigned short int *func, void *itmlst);
```

\$SETEF

Set Event Flag — Sets an event flag in a local or common event flag cluster. The condition value returned by \$SETEF indicates whether the specified flag was previously set or clear. After the event flag is set, processes waiting for the event flag to be set resume execution.

Format

```
SYS$SETEF efn
```

C Prototype

```
int sys$setef (unsigned int efn);
```

Argument

efn

OpenVMS usage:	ef_number
type:	longword (unsigned)
access:	read only
mechanism:	by value

Number of the event flag to be set. The *efn* argument is a longword containing this number; however, \$SETEF uses only the low-order byte.

Two local event flag clusters are local to the process: cluster 0 and cluster 1. Cluster 0 contains event flag numbers 0 to 31, and cluster 1 contains event flag numbers 32 to 63.

There are two common event flag clusters: cluster 2 and cluster 3. Cluster 2 contains event flag numbers 64 to 95, and cluster 3 contains event flag numbers 96 to 127.

Condition Values Returned

SS\$_WASCLR

The service completed successfully. The specified event flag was previously 0.

SS\$_WASSET

The service completed successfully. The specified event flag was previously 1.

SS\$_ILLEFC

You specified an illegal event flag number.

SS\$_UNASEFC

The process is not associated with the cluster containing the specified event flag.

\$SETEXV

Set Exception Vector — Assigns a condition handler address to the primary, secondary, or last chance exception vectors, or removes a previously assigned handler address from any of these three vectors.

Format

```
SYS$SETEXV [vector] , [address] , [acmode] , [prvhnd]
```

C Prototype

```
int sys$setexv
(unsigned int vector, int (*address)(__unknown_params),
 unsigned int acmode, void *(*(prvhnd)));
```

Arguments

vector

OpenVMS usage: longword_unsigned
type: longword (unsigned)
access: read only
mechanism: by value

Vector for which a condition handler is to be established or removed. The *vector* argument is a longword value. The value 0 (the default) specifies the primary exception vector; the value 1, the secondary vector; and the value 2, the last chance exception vector.

address

OpenVMS usage: procedure
type: procedure value
access: call without stack unwinding
mechanism: by reference

Condition handler address to be established for the exception vector specified by the *vector* argument. The *adres* argument is a longword value containing the address of the condition handler routine.

If you do not specify *adres* or specify it as the value 0, the condition handler address already established for the specified vector is removed; that is, the contents of the longword vector is set to 0.

acmode

OpenVMS usage: access_mode
type: longword (unsigned)
access: read only
mechanism: by value

Access mode for which the exception vector is to be modified. The *acmode* argument is a longword containing the access mode. The \$PSLDEF macro defines symbols for the four access modes.

The most privileged access mode used is the access mode of the caller. Exception vectors for access modes more privileged than the caller's access mode cannot be modified.

prvhnd

OpenVMS usage: procedure value
type: longword (unsigned)
access: write only
mechanism: by reference

Previous condition handler address contained by the specified exception vector. The *prvhnd* argument is the address of a longword into which \$SETEXV writes the handler's procedure value.

Description

The Set Exception Vector service (1) assigns a condition handler address to the primary, secondary, or last chance exception vectors or (2) removes a previously assigned handler address from any of these three vectors. A process cannot modify a vector associated with a more privileged access mode.

The operating system provides two different methods for establishing condition handlers:

- Using the call stack associated with each access mode. Each call frame includes a longword to contain the address of a condition handler associated with that frame.
- Using the software exception vectors (by using \$SETEXV) associated with each access mode. These vectors are set aside in the control region (P1 space) of the process.

The modular properties associated with the first method do not apply to the second. The software exception vectors are intended primarily for performance monitors and debuggers. For example, the primary exception vector and the last chance exception vector are used by the OpenVMS Debugger for user mode access, and DCL uses the last chance exception vector for supervisor mode access.

User mode exception vectors are canceled at image exit.

Required Access or Privileges

None

Required Quota

None

Related Services

\$DCLCMH, \$UNWIND

Condition Values Returned

SS\$_NORMAL

The service completed successfully.

SS\$_ACCVIO

The longword to receive the previous contents of the vector cannot be written by the caller.

\$SETFLT

Set Fault Characteristic on Pages — On Alpha and Integrity server systems, allows a process to change the fault characteristic on a page or range of pages.

Format

```
SYS$SETFLT inadr , [retadr] , [acmode] , fault_flag
```

C Prototype

```
int sys$setflt
    (struct _va_range *inadr, struct _va_range *retadr, unsigned int acmode,
     unsigned int fault_flag);
```

Arguments

inadr

OpenVMS usage: address_range
type: longword (unsigned)
access: read only
mechanism: by reference

Starting and ending virtual addresses of the range of pages whose fault characteristic is to be changed. The *inadr* argument is the address of a 2-longword array containing, in order, the starting and ending process virtual addresses.

Addresses are adjusted up or down to fall on CPU-specific page boundaries. Only the virtual page number portion of each virtual address is used; the low-order byte-within-page bits are ignored.

If the starting and ending virtual addresses are the same, the fault characteristic is changed for a single page.

retadr

OpenVMS usage: address_range
 type: longword (unsigned)
 access: write only
 mechanism: by reference—array reference or descriptor

Starting and ending virtual addresses of the range of pages whose fault characteristic was actually changed by \$SETFLT. The *retadr* argument is the address of a 2-longword array containing, in order, the starting and ending process virtual addresses.

If an error occurs while the fault characteristic is being changed, \$SETFLT writes into *retadr* the range of pages that were successfully changed before the error occurred. If no pages were affected before the error occurred, \$SETFLT writes the value --1 into each longword of the 2-longword array.

acmode

OpenVMS usage: access_mode
 type: longword (unsigned)
 access: read only
 mechanism: by value

Access mode associated with the call to \$SETFLT. The *acmode* argument is a longword containing the access mode. The \$PSLDEF macro defines symbols for the access modes.

The \$SETFLT service uses whichever of the following two access modes is less privileged: (1) the access mode specified by *acmode* or (2) the access mode of the caller. To change the fault characteristic of any page in the specified range, the resultant access mode must be equal to or more privileged than the access mode of the owner of that page.

fault_flag

OpenVMS usage: mask_longword
 type: longword (unsigned)
 access: read only
 mechanism: by value

Flag mask specifying the request options. The *fault_flag* argument is a longword bit vector in which each bit corresponds to a flag. The \$FLTDEF macro and the FLTDEF.H file define a symbolic name for each flag.

The \$FLTDEF macro defines the following symbolic names for the fault characteristic codes:

Symbol	Description
FLT\$M_NO_EXECUTE	Fault on execute access attempt
FLT\$M_EXECUTABLE	Allow execute access

If you specify the fault characteristic as the value 0, the characteristic defaults to no execute access.

Description

The Set Fault Characteristic on Pages service allows a process to change the fault characteristic on a page or range of pages.

Required Access or Privileges

None

Required Quota

None

Related Services

\$CRETVA, \$EXPREG, \$SETPRT

Condition Values Returned

SS\$_NORMAL

The service completed successfully.

SS\$_ACCVIO

The input address array cannot be read by the caller; the output address array or the byte to receive the previous protection cannot be written by the caller; or an attempt was made to change the fault characteristic of a nonexistent page.

SS\$_BADPARAM

A bad *fault_flag* argument was specified.

SS\$_LENVIO

A page in the specified range is beyond the end of the program or control region.

SS\$_NOPRIV

A page in the specified range is in the system address space.

SS\$_PAGOWNVIO

The process attempted to change the fault characteristic on a page owned by a more privileged access mode.

\$SETFLT_64

Set Fault Characteristic — On Alpha and Integrity server systems, allows a process to change the fault characteristic (for example, *no execute*) on a page or range of pages.

Format

```
$SETFLT_64
    start_va_64 , length_64 , acmode , fault_flag , return_va_64
    , return_length_64
```

Arguments

start_va_64

OpenVMS usage: address
type: quadword address
access: read only
mechanism: by value

The starting virtual address of the range of pages whose fault characteristic is to be changed. The specified virtual address will be rounded down to a CPU-specific page boundary.

length_64

OpenVMS usage: byte count
type: quadword (unsigned)
access: read only
mechanism: by value

Length of the virtual address space whose fault characteristic is to be changed. The specified length will be rounded up to a CPU-specific page boundary so that it includes all CPU-specific pages in the requested range.

acmode

OpenVMS usage: access_mode
type: longword (unsigned)
access: read only
mechanism: by value

Access mode associated with the call to \$SETFLT_64. The *acmode* argument is a longword containing the access mode. The \$PSLDEF macro defines symbols for the four access modes.

The most privileged access mode used is the access mode of the caller. The calling process can modify pages only if those pages are owned by an access mode equal to or less privileged than the access mode of the calling process.

fault_flag

OpenVMS usage: mask_longword
type: longword (unsigned)
access: read only
mechanism: by value

Flag mask specifying the request options. The *fault_flag* argument is a longword bit vector in which each bit corresponds to a flag. The \$FLTDEF macro and the FLTDEF.H file define a symbolic name for each flag.

The \$FLTDEF macro defines the following symbolic names for the fault characteristic codes:

Symbol	Description
FLT\$M_NO_EXECUTE	Fault on execute access attempt
FLT\$M_EXECUTABLE	Allow execute access

If you specify the fault characteristic as the value 0, the characteristic defaults to no execute access.

return_va_64

OpenVMS usage: address
type: quadword address
access: write only
mechanism: by 32-bit or 64-bit reference

The lowest process virtual address of the range of pages whose fault characteristics were actually changed.

return_length_64

OpenVMS usage: byte count
type: quadword (unsigned)
access: write only
mechanism: by 32-bit or 64-bit reference

The length of the virtual address range whose fault characteristics were actually changed. The *return_length_64* argument is the 32-bit or 64-bit virtual address of a naturally aligned quadword into which the service returns the length of the virtual address range in bytes.

Description

The Set Fault Characteristic service sets the fault characteristics (for example, *no execute*) for the specified range of pages, checking that the specified mode is at least as privileged as the owner of the page.

If the condition value SS\$_ACCVIO is returned by this service, a value **might not** be returned in the memory locations pointed to by the *return_va_64* and *return_length_64* arguments.

If a condition value other than SS\$_ACCVIO is returned, the returned address and returned length indicate the pages that were successfully changed before the error occurred. If no pages were changed, the *return_va_64* argument will contain the value -1, and a value **might not** be returned in the memory location pointed to by the *return_length_64* argument.

Required Privileges

None

Required Quota

None

Related Services

\$CRETVA_64, \$EXPREG_64, \$SETPRT_64

Condition Values Returned

SS\$_NORMAL

The service completed successfully.

SS\$_ACCVIO

The *return_va_64* or *return_length_64* argument cannot be written by the caller.

SS\$_BADPARAM

A bad *fault_flag* argument was specified.

SS\$_LENVIO

A page in the specified range is beyond the length of virtual addresses within that region.

SS\$_NOSUCHPAG

An attempt was made to change the fault characteristic on a nonexistent page.

SS\$_PAGNOTINREG

A page in the specified range is not in process private address space.

SS\$_PAGOWNVIO

The process attempted to change the protection on a page owned by a more privileged access mode.

\$SETIME

Set System Time — Changes the value of, or recalibrates, the system time. On Alpha and Integrity server systems, this service accepts 64-bit addresses.

Format

```
SYS$SETIME [timadr]
```

C Prototype

```
int sys$setime (struct _generic_64 *timadr);
```

Argument

timadr

OpenVMS usage: date_time
type: quadword (unsigned)
access: read only
mechanism: by 32- or 64-bit reference (Alpha and Integrity servers)

New absolute time value for the system time, specifying the number of 100-nanosecond intervals since 00:00 o'clock, November 17, 1858. The *timadr* argument is the 32- or 64-bit address (on Alpha and Integrity server systems) of a quadword containing the new system time value. A negative (delta) time value is invalid.

If you do not specify the value of *timadr* or specify it as 0, \$SETIME recalibrates the system time using the time-of-year clock.

Description

The Set System Time service (1) changes the value of or (2) recalibrates the system time which is defined by a quadword value that specifies the number of 100-nanosecond intervals since 00:00 o'clock, November 17, 1858.

System time is the reference used for nearly all timer-related software activities in the operating system. After changing or recalibrating the system clock, \$SETIME updates the timer queue by adjusting each element in the timer queue by the difference between the previous system time and the new system time.

The \$SETIME service saves the new time (for future bootstrap operations) in the system image SYS\$LOADABLE_IMAGES:SYS\$BASE_IMAGE.EXE on Alpha and Integrity server systems. To save the time, the service assigns a channel to the system boot device and calls \$QIOW. You need the LOG_IO user privilege to perform this operation.

Required Access or Privileges

To set system time, the calling process must have OPER, LOG_IO, and SYSPRV privileges.

Required Quota

None

Related Services

\$ASCTIM, \$BINTIM, \$CANTIM, \$CANWAK, \$GETTIM, \$NUMTIM, \$SCHDWK, \$SETIMR

Condition Values Returned

SS\$_NORMAL

The service completed successfully.

SS\$_ACCVIO

The quadword that contains the new system time value cannot be read by the caller.

SS\$_IVTIME

The caller specified no time value or a negative time value and an invalid processor clock was found.

SS\$_NOIOCHAN

No I/O channel is available for assignment.

SS\$_NOPRIV

The process does not have the privileges to set the system time.

\$SETIMR

Set Timer — Sets the timer to expire at a specified time. On Alpha and Integrity server systems, this service accepts 64-bit addresses.

Format

```
SYS$SETIMR [efn] ,daytim ,[astadr] ,[reqidt] ,[flags]
```

C Prototype

```
int sys$setimr
(unsigned int efn, struct _generic_64 *daytim,
 void (*astadr)(__unknown_params), unsigned __int64 reqidt,
 unsigned int flags);
```

Arguments

efn

OpenVMS usage: ef_number
type: longword (unsigned)
access: read only
mechanism: by value

Event flag to be set when the timer expires. The *efn* argument is a longword value containing the number of the event flag; however, \$SETIMR uses only the low-order byte. If you do not specify *efn*, event flag 0 is used.

When \$SETIMR first executes, it clears the specified event flag or event flag 0.

daytim

OpenVMS usage: date_time
type: quadword
access: read only
mechanism: by 64-bit reference (Alpha and Integrity servers)

Time at which the timer expires. The *daytim* argument is the 64-bit address (on Alpha and Integrity server systems) of a quadword time value. A positive time value specifies an absolute time at which the timer expires; a negative time value specifies an offset (delta time) from the current time.

astadr

OpenVMS usage: ast_procedure
type: procedure value
access: call without stack unwinding
mechanism: by 64-bit reference (Alpha and Integrity servers)

AST service routine that is to execute when the timer expires. The *astadr* argument is the 64-bit address (on Alpha and Integrity server systems) of the procedure value of this routine. If you do not specify the value of *astadr* or specify it as 0 (the default), no AST routine executes.

The AST routine, if specified, executes at the access mode of the caller.

reqidt

OpenVMS usage: user_arg
type: quadword
access: read only
mechanism: by value

Identification of the timer request. The *reqidt* argument is a quadword value containing a number that uniquely identifies the timer request. If you do not specify *reqidt*, the value 0 is used.

To cancel a timer request, the identification of the timer request (as specified by *reqidt* in \$SETIMR) is passed to the Cancel Timer (\$CANTIM) service (as the *reqidt* argument).

If you want to cancel specific timer requests but not all timer requests, be sure to specify a nonzero value for *reqidt* in the \$SETIMR call; \$CANTIM interprets an identification value of 0 as a request to cancel all timer requests.

You can specify unique values for *reqidt* for each timer request or give the same value to related timer requests. This permits selective canceling of a single timer request, a group of related timer requests, or all timer requests.

If you specify the *astadr* argument in the \$SETIMR call, the value specified by the *reqidt* argument is passed as a parameter to the AST routine. If the AST routine requires more than one parameter, specify an address for the value of *reqidt*; the AST routine can then interpret that address as the beginning of a list of parameters.

flags

OpenVMS usage: mask_longword
type: longword (unsigned)
access: read only
mechanism: by value

Longword of bit flags for the set timer operation. Currently, only bit 0 is used for the *flags* argument. When the low bit (bit 0) is set, it indicates that this timer request should be in units of CPU time, rather than elapsed time. When bit 0 is clear (the default), the timer request is in units of elapsed time. The *flags* argument is optional.

Description

The Set Timer service sets the timer to expire at a specified time. When the timer expires, an event flag is set and (optionally) an AST routine executes. This service requires dynamic memory and executes at the access mode of the caller, as does the AST routine if one is specified.

Required Access or Privileges

None

Required Quota

This service uses the process's timer queue entries (TQELM) quota. If you specify an AST routine, the service uses the AST limit (ASTLM) quota of the process.

Related Services

\$ASCTIM, \$BINTIM, \$CANTIM, \$SCANWAK, \$GETTIM, \$NUMTIM, \$SCHDWK, \$SETIME

Condition Values Returned

SS\$_NORMAL

The service completed successfully.

SS\$_ACCVIO

The expiration time cannot be read by the caller.

SS\$_EXQUOTA

The process exceeded its quota for timer entries or its AST limit quota; or the system dynamic memory is insufficient for completing the request.

SS\$_ILLEFC

You specified an illegal event flag number.

SS\$_INSFMEM

The dynamic memory is insufficient for allocating a timer queue entry.

SS\$_UNASEFC

The process is not associated with the cluster containing the specified event flag.

\$SETPRA

Set Power Recovery AST — Establishes a routine to receive control after a power recovery is detected.

Format

```
SYS$SETPRA astadr , [acmode]
```

C Prototype

```
int sys$setpra (int (*astadr) (__unknown_params), unsigned int acmode);
```

Arguments

astadr

OpenVMS usage: ast_procedure
type: procedure value
access: call without stack unwinding
mechanism: by reference

Power recovery AST routine to receive control when a power recovery is detected. The *astadr* argument is the address of this routine.

If you specify *astadr* as the value 0, an AST is not delivered to the process when a power recovery is detected.

The system passes one parameter to the specified AST routine. This parameter is a longword value containing the length of time that the power was off, expressed as the number of 1/100th-of-a-second intervals that have elapsed.

acmode

OpenVMS usage: access_mode
type: longword (unsigned)
access: read only
mechanism: by value

Access mode at which the power recovery AST routine is to execute. The *acmode* argument is a longword containing the access mode. The \$PSLDEF macro defines symbols for the access modes.

The most privileged access mode used is the access mode of the caller.

Description

The Set Power Recovery AST service establishes a routine to receive control after a power recovery is detected.

You can specify only one power recovery AST routine for a process. The AST entry point address is cleared at image exit.

The entry and exit conventions for the power recovery AST routine are the same as for all AST service routines.

Required Access or Privileges

None

Required Quota

One unit of quota is deducted from the process's ASTLM.

Related Services

\$DCLAST, \$SETAST

For more information, see the chapter on AST services in the *VSI OpenVMS Programming Concepts Manual*.

Condition Values Returned

SS\$_NORMAL

The service completed successfully.

SS\$_EXQUOTA

The process exceeded its quota for outstanding AST requests.

\$SETPRI

Set Priority — Changes the base priority of the process. The base priority is used to determine the order in which executable processes are to run.

Format

```
SYSS$SETPRI
    [pidadr] , [prcnam] , pri , [prvpri] , [nullarg] , [nullarg]
```

C Prototype

```
int sys$setpri
    (unsigned int *pidadr, void *prcnam, unsigned int pri,
     unsigned int *prvpri, unsigned int *pol, unsigned int *prvpol);
```

Arguments

pidadr

OpenVMS usage: process_id
type: longword (unsigned)
access: modify
mechanism: by reference

Process identification (PID) of the process whose priority is to be set. The *pidadr* argument is the address of the PID. The *pidadr* argument can refer to a process running on the local node or a process running on another node in the cluster.

prcnam

OpenVMS usage: process_name
type: character-coded text string
access: read only

mechanism: by descriptor–fixed-length string descriptor

Process name of the process whose priority is to be changed. The *prcnam* argument is the address of a character string descriptor pointing to the process name.

A process running on the local node can be identified with a 1- to 15-character string. To identify a process on a particular node on a cluster, specify the full process name, which includes the node name as well as the process name. The full process name can contain up to 23 characters.

You can use the *prcnam* argument only on behalf of processes in the same UIC group as the calling process. To set the priority for processes in other groups, you must specify the *pidadr* argument.

pri

OpenVMS usage: longword_unsigned
 type: longword (unsigned)
 access: read only
 mechanism: by value

New base priority to be established for the process. The *pri* argument is a longword value containing the new priority. Priorities that are not real time are in the range 0 through 15; real-time priorities are in the range 16 through 31.

If the specified priority is higher than the base priority of the target process, and if the caller does not have ALTPRI privilege, then the base priority of the target process is used.

prvpri

OpenVMS usage: longword_unsigned
 type: longword (unsigned)
 access: write only
 mechanism: by reference

Base priority of the process before the call to \$SETPRI. The *prvpri* argument is the address of a longword into which \$SETPRI writes the previous base priority of the process.

policy

OpenVMS usage: longword_unsigned
 type: longword (unsigned)
 access: read only
 mechanism: by reference

On Alpha and Integrity server systems, address of a longword containing the new scheduling policy for the process.

The \$JPIDEF macro defines the following symbols for the policy argument:

Symbol	Meaning
JPI\$K_DEFAULT_POLICY	The normal scheduling policy. The priority interval for this policy is defined as [0.. n], such that priorities [0..15] are interactive and priorities [16.. n] are real time.

Symbol	Meaning
JPI\$K_P\$X_FIFO_POLICY	POSIX FIFO scheduling policy. The priority interval for this policy is defined as [n.. m] real-time priorities.
JPI\$K_P\$X_RR_POLICY	POSIX round-robin policy. The priority interval for this policy is defined as [n.. m] real-time priorities.

prvpol

OpenVMS usage: longword_unsigned
type: longword (unsigned)
access: write only
mechanism: by reference

On Alpha and Integrity server systems, address of a longword into which the previous scheduling policy for the process is written. If the *policy* argument is null, no change in policy is requested and *prvpol* returns the current policy.

The valid priority intervals for specific scheduling policies might change in the future. Applications should, therefore, not use embedded numeric constants for scheduling priority, but should use the appropriate \$GETSYI item codes to fetch the legal priority intervals. The application can then dynamically select a priority value that is within the interval. The \$GETSYI item codes are:

- SYI\$_DEF_P\$RIO_MAX, SYI\$_DEF_P\$RIO_MIN
- SYI\$_P\$XFIFO_P\$RIO_MAX, SYI\$_P\$XFIFO_P\$RIO_MIN
- SYI\$_P\$XR\$R_P\$RIO_MAX, SYI\$_P\$XR\$R_P\$RIO_MIN

See the Item Codes section of the \$GETSYI service description for more information about these item codes.

nullarg

OpenVMS usage: null_arg
type: longword (unsigned)
access: read only
mechanism: by value

Placelholding argument reserved to OpenVMS.

Description

The Set Priority service changes the base priority of the process or, optionally, changes the scheduling policy of the process. The base priority is used to determine the order in which executable processes are to run.

The scheduling policy denotes the following:

- The basic scheduling discipline (FIFO, round-robin, and so forth).
- The preemption/compensation rules by which a running process is descheduled in favor of another process and, ultimately, rescheduled.

A source process can modify the priority or scheduling policy of a target process if *any* of the following are true:

- The source and target processes are in the same job tree.
- The source and target processes have the same UIC.
- The source process has WORLD privilege enabled.
- The source and target processes are in the same process group.

The value to which the priority of a process can be set can be subject to limitations. If the source has ALTPRI privilege enabled, the target can be set to any valid priority. Otherwise, the priority value specified by the source process is compared to the authorized priority of the target process and the smaller of the two values is used as the new base priority of the target process.

If you specify neither the *pidadr* nor the *prcnam* argument, \$SETPRI sets the base priority of the calling process.

If the longword at address *pidadr* is the value 0, the PID of the target process is returned.

The base priority of a process remains in effect until specifically changed or until the process is deleted.

To determine the priority set by the \$SETPRI service, use the Get Job/Process Information (\$GETJPI) service.

Required Access or Privileges

Depending on the operation, the calling process might need one of the following privileges to use \$SETPRI:

- GROUP privilege to change the priority of a process in the same group, unless the target process has the same UIC as the calling process.
- WORLD privilege to change the priority of any other process in the system.
- ALTPRI privilege to set any process's priority to a value greater than the target process's initial base priority. If a process does not have ALTPRI privilege, the priority value specified by the source process is compared to the authorized priority of the target process and the smaller of the two values is used as the new base priority of the target process.

Required Quota

None

Related Services

\$SCANEXH, \$CREPRC, \$DCLEXH, \$DELPRC, \$EXIT, \$FORCEX, \$GETJPI, \$GETJPIW, \$HIBER, \$PROCESS_SCAN, \$RESUME, \$SETPRN, \$SETPRV, \$SETRWM, \$SUSPND, \$WAKE

Condition Values Returned

SS\$_NORMAL

The service completed successfully.

SS\$_ACCVIO

The process name string or string descriptor cannot be read by the caller, or the process identification or previous priority longword cannot be written by the caller.

SS\$_ILLPOLICY

An invalid scheduling policy was specified.

SS\$_ILLPRIPOL

Setting the process to the specified priority and/or policy would result in an illegal policy/priority combination. The illegal combination can occur between the SETPRI policy and priority parameters themselves, or it can occur between either of the parameters and the current policy and/or priority of the target process.

SS\$_INCOMPAT

The remote node is running an incompatible version of the operating system.

SS\$_IVLOGNAM

The process name string has a length of 0 or has more than 15 characters.

SS\$_NONEXPR

The specified process does not exist, or an invalid process identification was specified.

SS\$_NOPRIV

The process does not have the privilege to affect other processes.

SS\$_NOSUCHNODE

The process name refers to a node that is not currently recognized as part of the cluster.

SS\$_REMRSRC

The remote node has insufficient resources to respond to the request. (Bring this error to the attention of your system manager.)

SS\$_UNREACHABLE

The remote node is a member of the cluster but is not accepting requests. (This is normal for a brief period early in the system boot process.)

\$SETPRN

Set Process Name — Allows a process to establish or to change its own process name.

Format

`SYS$SETPRN [prcnam]`

C Prototype

```
int sys$setprn ( void *prcnam);
```

Argument

prcnam

OpenVMS usage: process_name
type: character-coded text string
access: read only
mechanism: by descriptor—fixed length string descriptor

Process name to be given to the calling process. The *prcnam* argument is the address of a character string descriptor pointing to a 1- to 15-character process name string. If you do not specify *prcnam*, the calling process is given no name.

Description

The Set Process Name service allows a process to establish or to change its own process name, which remains in effect until you change it (using \$SETPRN) or until the process is deleted. Process names provide an identification mechanism for processes executing with the same group number. A process can also be identified by its process identification (PID).

Required Access or Privileges

None

Required Quota

None

Related Services

\$SCANEXH, \$CREPRC, \$DCLEXH, \$DELPRC, \$EXIT, \$FORCEX, \$GETJPI, \$GETJPIW, \$HIBER, \$PROCESS_SCAN, \$RESUME, \$SETPRI, \$SETPRV, \$SETRWM, \$SUSPND, \$WAKE

Condition Values Returned

SS\$_NORMAL

The service completed successfully.

SS\$_ACCVIO

The process name string or string descriptor cannot be read by the caller.

SS\$_DUPLNAM

The specified process name duplicates one already specified within that group.

SS\$_IVLOGNAM

The specified process name has a length of 0 or has more than 15 characters.

\$SETPRT

Set Protection on Pages — Allows a process to change the protection on a page or range of pages.

Format

```
SYS$SETPRT inadr , [retadr] , [acmode] , prot , [prvprt]
```

C Prototype

```
int sys$setprt
    (struct _va_range *inadr, struct _va_range *retadr, unsigned int
    acmode,
    unsigned int prot, unsigned char *prvprt);
```

Arguments

inadr

OpenVMS usage: address_range
type: longword (unsigned)
access: read only
mechanism: by reference

Starting and ending virtual addresses of the range of pages whose protection is to be changed. The *inadr* argument is the address of a 2-longword array containing, in order, the starting and ending process virtual addresses.

Addresses are adjusted up or down to fall on CPU-specific page boundaries. Only the virtual page number portion of each virtual address is used; the low-order byte-within-page bits are ignored.

If the starting and ending virtual addresses are the same, the protection is changed for a single page.

retadr

OpenVMS usage: address_range
type: longword (unsigned)
access: write only
mechanism: by reference—array reference or descriptor

Starting and ending virtual addresses of the range of pages whose protection was actually changed by \$SETPRT. The *retadr* argument is the address of a 2-longword array containing, in order, the starting and ending process virtual addresses.

If an error occurs while the protection is being changed, \$SETPRT writes into *retadr* the range of pages that were successfully changed before the error occurred. If no pages were affected before the error occurred, \$SETPRT writes the value -1 into each longword of the 2-longword array.

acmode

OpenVMS usage: access_mode
 type: longword (unsigned)
 access: read only
 mechanism: by value

Access mode associated with the call to \$SETPRT. The *acmode* argument is a longword containing the access mode. The \$PSLDEF macro defines symbols for the access modes.

The \$SETPRT service uses whichever of the following two access modes is least privileged: (1) the access mode specified by *acmode* or (2) the access mode of the caller. To change the protection of any page in the specified range, the resultant access mode must be equal to or more privileged than the access mode of the owner of that page.

prot

OpenVMS usage: page_protection
 type: longword (unsigned)
 access: read only
 mechanism: by value

Page protection to be assigned to the specified pages. The *prot* argument is a longword value containing the protection code. Only bits 0 to 3 are used; bits 4 to 31 are ignored.

The \$PRTDEF macro defines the following symbolic names for the protection codes.

Symbol	Description
PRT\$C_NA	No access
PRT\$C_KR	Kernel read only
PRT\$C_KW	Kernel write
PRT\$C_ER	Executive read only
PRT\$C_EW	Executive write
PRT\$C_SR	Supervisor read only
PRT\$C_SW	Supervisor write
PRT\$C_UR	User read only
PRT\$C_UW	User write
PRT\$C_ERKW	Executive read; kernel write
PRT\$C_SRKW	Supervisor read; kernel write
PRT\$C_SREW	Supervisor read; executive write
PRT\$C_URKW	User read; kernel write
PRT\$C_UREW	User read; executive write
PRT\$C_URSW	User read; supervisor write

OpenVMS Alpha and Integrity server systems convert PRT\$C_NA to the next highest protection, kernel-read.

If you specify the protection as the value 0, the protection defaults to kernel read only.

prvprt

OpenVMS usage: page_protection
type: byte (unsigned)
access: write only
mechanism: by reference

Protection previously assigned to the last page in the range. The *prvprt* argument is the address of a byte into which \$SETPRT writes the protection of this page. The *prvprt* argument is useful only when protection for a single page is being changed.

Description

The Set Protection on Pages service allows a process to change the protection on a page or range of pages.

Required Access or Privileges

None

Required Quota

If a process changes the protection for any pages in a private section from read only to read/write, \$SETPRT uses the paging file (PGFLQUOTA) quota of the process.

For pages in global sections, the new protection can alter only copy-on-reference pages.

Related Services

\$ADJSTK, \$ADJWSL, \$CRETVA, \$CRMPSC, \$DELTVA, \$DGBLSC, \$EXPREG, \$LCKPAG, \$LKWSET, \$MGBLSC, \$PURGWS, \$SETSTK, \$SETSWM, \$ULKPAG, \$ULWSET, \$UPDSEC, \$UPDSECW

Condition Values Returned

SS\$_NORMAL

The service completed successfully.

SS\$_ACCVIO

The input address array cannot be read by the caller; the output address array or the byte to receive the previous protection cannot be written by the caller; or an attempt was made to change the protection of a nonexistent page.

SS\$_EXQUOTA

The process exceeded its paging file quota while changing a page in a read-only private section to a read/write page.

SS\$_IVPROTECT

The specified protection code has a numeric value of 1, less than 0, or greater than 15.

SS\$_LENVIO

A page in the specified range is beyond the end of the program or control region.

SS\$_NOPRIV

A page in the specified range is in the system address space; an attempt was made to change the protection of a valid global page, of an invalid global noncopy-on-reference page, or a PFN global or private page.

SS\$_PAGOWNVIO

The process attempted to change the protection on a page owned by a more privileged access mode.

\$SETPRT_64 (Alpha and Integrity servers)

Set Protection on Pages — On Alpha and Integrity server systems, allows a process to change the protection on a page or range of pages. This service accepts 64-bit addresses.

Format

```
SYSS$SETPRT_64
    start_va_64 , length_64 , acmode , prot , return_va_64 , return_length_64
    , return_prot_64
```

C Prototype

```
int sys$setprt_64
    (void *start_va_64, unsigned __int64 length_64, unsigned int acmode,
    unsigned int prot, void *(*return_va_64),
    unsigned __int64 *return_length_64, unsigned int *return_prot_64);
```

Arguments

start_va_64

OpenVMS usage: address
type: quadword address
access: read only
mechanism: by value

The starting virtual address of the range of pages whose protection is to be changed. The specified virtual address will be rounded down to a CPU-specific boundary.

length_64

OpenVMS usage: byte count
type: quadword (unsigned)
access: read only
mechanism: by value

Length of the virtual address space whose protection is to be changed. The specified length will be rounded up to a CPU-specific page boundary so that it includes all CPU-specific pages in the requested range.

acmode

OpenVMS usage: `access_mode`
 type: longword (unsigned)
 access: read only
 mechanism: by value

Access mode associated with the call to `$SETPRT_64`. The *acmode* argument is a longword containing the access mode.

The `$PSLDEF` macro in `STARLET.MLB` and the file `PSLDEF.H` in `SY$STARLET_C.TLB` define the following symbols and their values for the four access modes:

Value	Symbolic Name	Access Mode
0	PSL\$C_KERNEL	Kernel
1	PSL\$C_EXEC	Executive
2	PSL\$C_SUPER	Supervisor
3	PSL\$C_USER	User

The most privileged access mode used is the access mode of the caller. To change the protection of any page in the specified range, the resultant access mode must be equal to or more privileged than the access mode of the owner of that page.

prot

OpenVMS usage: `page_protection`
 type: longword (unsigned)
 access: read only
 mechanism: by value

Page protection to be assigned to the specified pages. The *prot* argument is a longword value containing the protection code. Only bits 0 to 3 are used; bits 4 to 31 are ignored.

The `$PRTDEF` macro for MACRO-32 and the include file `PRTDEF.H` for C define the symbolic names for the protection codes.

return_va_64

OpenVMS usage: `address`
 type: quadword address
 access: write only
 mechanism: by 32- or 64-bit reference

The lowest process virtual address of the range of pages whose protection was actually changed. The *return_va_64* argument is the 32- or 64-bit virtual address of a naturally aligned quadword into which the service returns the virtual address.

return_length_64

OpenVMS usage: byte count
type: quadword (unsigned)
access: write only
mechanism: by 32- or 64-bit reference

The length of the virtual address range whose protection was actually changed. The *return_length_64* argument is the 32- or 64-bit virtual address of a naturally aligned quadword into which the service returns the length of the virtual address range in bytes.

return_prot_64

OpenVMS usage: page_protection
type: longword (unsigned)
access: write only
mechanism: by 32- or 64-bit reference

Protection previously assigned to the last page in the range. The *return_prot_64* argument is the 32- or 64-bit virtual address of a naturally aligned longword into which \$SETPRT_64 writes the protection of this page. The *return_prot_64* argument is useful only when protection for a single page is being changed.

Description

The Set Protection on Pages service allows a process to change the protection on a page or range of pages. For pages in a global section, the new protection can alter only copy-on-reference pages.

If the condition value SS\$_ACCVIO is returned by this service, a value *cannot* be returned in the memory locations pointed to by the *return_va_64*, *return_length_64*, and *return_prot* arguments.

If a condition value other than SS\$_ACCVIO is returned, the returned address and returned length indicate the pages that were successfully changed before the error occurred. If no pages were changed, the *return_va_64* argument will contain the value -1, and a value *cannot* be returned in the memory location pointed to by the *return_length_64* argument.

Required Privileges

None

Required Quota

If a process changes the protection for any pages in a private section from read-only to read/write, \$SETPRT_64 uses the paging file (PGFLQUOTA) quota of the process.

Related Services

\$CRETVA_64, \$CRMPSC_FILE_64, \$CRMPSC_GFILE_64, \$CRMPSC_GPFILE_64,
\$EXPREG_64, \$MGBLSC_64

Condition Values Returned

SS\$_NORMAL

The service completed successfully.

SS\$_ACCVIO

The *return_va_64* or the *return_length_64* argument cannot be written by the caller.

SS\$_EXPGFLQUOTA

The process exceeded its paging file quota while changing a page in a read-only private section to a read/write page.

SS\$_IVPROTECT

The specified protection code has a numeric value of 1 or is greater than 15.

SS\$_LENVIO

A page in the specified range is not in process private address space.

SS\$_NOSUCHPAG

An attempt was made to change the protection on a nonexistent page.

SS\$_PAGNOTINREG

A page in the specified range is not within the specified region.

SS\$_PAGTYPVIO

A page in the specified range is not in process private address space.

SS\$_PAGOWNVIO

The process attempted to change the protection on a page owned by a more privileged access mode.

\$SETPRV

Set Privileges — Enables or disables specified privileges for the calling process.

Format

```
SYS$SETPRV [enbflg] , [prvadr] , [prmflg] , [prvprv]
```

C Prototype

```
int sys$setprv
(char enbflg, struct _generic_64 *prvadr, char prmflg,
 struct _generic_64 *prvprv);
```

Arguments

enbflg

OpenVMS usage: boolean
 type: longword (unsigned)
 access: read only
 mechanism: by value

Indicator specifying whether the specified privileges are to be enabled or disabled. The *enbflg* argument is a longword value. The value 1 indicates that the privileges specified in the *prvadr* argument are to be enabled. The value 0 (the default) indicates that the privileges are to be disabled.

prvadr

OpenVMS usage: mask_privileges
 type: quadword (unsigned)
 access: read only
 mechanism: by reference

Privileges to be enabled or disabled for the calling process. The *prvadr* argument is the address of a quadword bit vector wherein each bit corresponds to a privilege that is to be enabled or disabled.

Each bit has a symbolic name. The \$PRVDEF macro defines these names. You form the bit vector by specifying the symbolic name of each desired privilege in a logical OR operation. Table 10 provides the symbolic name and description of each privilege.

Table 10. User Privileges

Privilege	Symbolic Name	Description
ACNT	PRV\$_M_ACNT	Create processes for which no accounting is done
ALLSPOOL	PRV\$_M_ALLSPOOL	Allocate a spooled device
ALTPRI	PRV\$_M_ALTPRI	Set (alter) any process priority
AUDIT	PRV\$_V_AUDIT	Generate audit records
BUGCHK	PRV\$_M_BUGCHK	Make bugcheck error log entries
BYPASS	PRV\$_M_BYPASS	Bypass all protection
CMEXEC	PRV\$_M_CMEXEC	Change mode to executive
CMKRNL	PRV\$_M_CMKRNL	Change mode to kernel
DIAGNOSE	PRV\$_M_DIAGNOSE	Can diagnose devices
DOWNGRADE	PRV\$_V_DOWNGRADE	Can downgrade classification
EXQUOTA	PRV\$_M_EXQUOTA	Can exceed quotas
GROUP	PRV\$_M_GROUP	Group process control
GRPNAM	PRV\$_M_GRPNAM	Place name in group logical name table
GRPPRV	PRV\$_V_GRPPRV	Group access by means of system protection field
IMPERSONATE	PRV\$_M_IMPERSONATE	Create detached processes under another UIC
IMPORT	PRV\$_V_IMPORT	Mount a nonlabeled tape volume

Privilege	Symbolic Name	Description
LOG_IO	PRV\$M_LOG_IO	Perform logical I/O operations
MOUNT	PRV\$M_MOUNT	Issue mount volume QIO
NETMBX	PRV\$M_NETMBX	Create a network device
OPER	PRV\$M_OPER	All operator privileges
PFNMAP	PRV\$M_PFNMAP	Map to section by physical page frame number
PHY_IO	PRV\$M_PHY_IO	Perform physical I/O operations
PRMCEB	PRV\$M_PRMCEB	Create permanent common event flag clusters
PRMGBL	PRV\$M_PRMGBL	Create permanent global sections
PRMMBX	PRV\$M_PRMMBX	Create permanent mailboxes
PSWAPM	PRV\$M_PSWAPM	Change process swap mode
READALL	PRV\$V_READALL	Possess read access to everything
SECURITY	PRV\$V_SECURITY	Can perform security functions
SETPRV	PRV\$M_SETPRV	Set any process privileges
SHARE	PRV\$M_SHARE	Can assign a channel to a nonshared device
SHMEM	PRV\$M_SHMEM	Allocate structures in memory shared by multiple processors
SYSGBL	PRV\$M_SYSGBL	Create system global sections
SYSLCK	PRV\$M_SYSLCK	Queue systemwide locks
SYSNAM	PRV\$M_SYSNAM	Place name in system logical name table
SYSPRV	PRV\$M_SYSPRV	Access files and other resources as if you have a system UIC
TMPMBX	PRV\$M_TMPMBX	Create temporary mailboxes
UPGRADE	PRV\$V_UPGRADE	Can upgrade classification
VOLPRO	PRV\$M_VOLPRO	Override volume protection
WORLD	PRV\$M_WORLD	World process control

If you do not specify *prvadr* or assign it the value 0, the privileges are not altered.

prmflg

OpenVMS usage: boolean
type: longword (unsigned)
access: read only
mechanism: by value

Indicator specifying whether the privileges are to be affected permanently or temporarily. The *prmflg* argument is a longword value. The value 1 specifies that the privileges are to be affected permanently, that is, until you change them again by using \$SETPRV or until the process is deleted. The value 0 (the default) specifies that the privileges are to be affected temporarily, that is, until the current image exits (at which time the permanently enabled privileges of the process will be restored).

Setting the *prmflg* argument to nonzero changes privilege bits in both the CURPRIV mask and the PROCPRIV mask.

prvprv

OpenVMS usage: mask_privileges
type: quadword (unsigned)
access: write only
mechanism: by reference

Privileges previously possessed by the calling process. The *prvprv* argument is the address of a quadword bit vector wherein each bit corresponds to a privilege that was previously either enabled or disabled. If you do not specify *prvprv* or assign it the value 0, the previous privilege mask is not returned.

Description

The Set Privileges service enables or disables specified privileges for the calling process.

The operating system maintains four separate privilege masks for each process:

- AUTHPRIV—Privileges that the process is authorized to enable, as designated by the system manager or the process creator. The AUTHPRIV mask never changes during the life of the process.
- PROCPRIV—Privileges that are designated as permanently enabled for the process. The PROCPRIV mask can be modified by \$SETPRV.
- IMAGPRIV—Privileges with which the current image is installed.
- CURPRIV—Privileges that are currently enabled. The CURPRIV mask can be modified by \$SETPRV.

When a process is created, its AUTHPRIV, PROCPRIV, and CURPRIV masks have the same contents. Whenever a system service (other than \$SETPRV) must check the process privileges, that service checks the CURPRIV mask.

When a process runs an installed image, the privileges with which that image was installed are enabled in the CURPRIV mask. When the installed image exits, the PROCPRIV mask is copied to the CURPRIV mask.

The \$SETPRV service can set bits only in the CURPRIV and PROCPRIV mask, but \$SETPRV checks the AUTHPRIV mask to see whether a process can set specified privilege bits in the CURPRIV or PROCPRIV masks. Consequently, a process can give itself the SETPRV privilege only if this privilege is enabled in the AUTHPRIV mask.

You can obtain each of a process's four privilege masks by calling the \$GETJPI (Get Job/Process Information) service and specifying the desired privilege mask or masks as item codes in the *itmlst* argument. You construct the item code for a privilege mask by prefixing the name of the privilege mask with the characters JPI\$_ (for example, JPI\$_CURPRIV is the item code for the current privilege mask).

The DCL command SET PROCESS/PRIVILEGES also enables or disables specified privileges; refer to the *VSI OpenVMS DCL Dictionary* for details.

Required Access or Privileges

To set a privilege permanently, the calling process must be authorized to set the specified privilege, or the process must be executing in kernel or executive mode.

To set a privilege temporarily, one of the following three conditions must be true:

- The calling process must be authorized to set the specified privilege.
- The calling process must be executing in kernel or executive mode.
- The image currently executing must be one that was installed with the specified privilege.

Required Quota

None

Related Services

\$SCANEXH, \$CMKRNL, \$CREPRC, \$DCLEXH, \$DELPRC, \$EXIT, \$FORCEX, \$GETJPI, \$GETJPIW, \$HIBER, \$PROCESS_SCAN, \$RESUME, \$SETPRI, \$SETPRN, \$SETRWM, \$SUSPND, \$WAKE

Condition Values Returned

SS\$_NORMAL

The service completed successfully. All privileges were enabled or disabled as specified.

SS\$_NOTALLPRIV

The service completed successfully. Not all specified privileges were enabled; see the Description section for details.

SS\$_ACCVIO

The privilege mask cannot be read or the previous privilege mask cannot be written by the caller.

SS\$_IVSTSFLG

You specified a value other than 1 or 0 in either the *prmflg* argument or the *enblfg* argument.

\$SETRWM

Set Resource Wait Mode — Allows a process to specify what action system services should take when system resources required for their execution are unavailable.

Disabling resource waiting should be performed with caution, as doing so can have unexpected effects on constituent sharable images and runtime libraries.

Caution: Disabling resource waiting should be performed with caution, as doing so can have unexpected effects on constituent sharable images and runtime libraries.

Format

```
SYS$SETRWM [watflg]
```

C Prototype

```
int sys$setrwm ( char watflg);
```

Argument

watflg

OpenVMS usage: longword_unsigned
type: longword (unsigned)
access: read only
mechanism: by value

Indicator specifying whether system services should wait for required resources. The *watflg* argument is a longword value. The value 0 (the default) specifies that system services should wait until resources needed for their execution become available. The value 1 specifies that system services should return failure status immediately when resources needed for their execution are unavailable.

The operating system enables resource wait mode for all processes. You can disable resource wait mode only by calling \$SETRWM.

If resource wait mode is disabled, it remains disabled until it is explicitly reenabled or until the process is deleted.

Description

The Set Resource Wait Mode service allows a process to specify what action system services should take when system resources required for their execution are unavailable. When resource wait mode is enabled, system services wait for the required system resources to become available and then continue execution. When resource wait mode is disabled, system services return to the caller when required system resources are unavailable. The condition value returned by \$SETRWM indicates whether resource wait mode was previously enabled or previously disabled.

The following system resources and process quotas are affected by resource wait mode:

- System dynamic memory: nonpaged pool, lock manager dynamic memory¹
- UNIBUS adapter map registers
- Direct I/O limit (DIOLM) quota
- Buffered I/O limit (BIOLM) quota
- Buffered I/O byte count limit (BYTLM) quota
- Timer queue quota
- Mailbox buffer quota
- Insufficient pipe quota

Caution

Due to the process-wide implications of resource waiting, disabling resource waiting should be performed with caution.

¹Also, physical memory or system page table entries under rare circumstances.

Disabling resource wait mode can have unexpected effects on libraries or shareable images upon which your application may be directly or indirectly dependent. If resource waiting is disabled, these constituent libraries or shareable images may not perform as expected. It is possible that these constituent components are coded to assume resource waiting is enabled; therefore, they may not be coded to receive various quota-related errors such as `SS$_EXQUOTA`.

Note that you should have full control over the entire program context down to the system calls before disabling resource wait mode.

Required Access or Privileges

None

Required Quota

None

Related Services

`$SCANEXH`, `$CREPRC`, `$DCLEXH`, `$DELPRC`, `$EXIT`, `$FORCEX`, `$GETJPI`, `$GETJPIW`, `$HIBER`, `$PROCESS_SCAN`, `$RESUME`, `$SETPRI`, `$SETPRN`, `$SETPRV`, `$SUSPND`, `$WAKE`

Condition Values Returned

`SS$_WASCLR`

The service completed successfully. Resource wait mode was previously enabled.

`SS$_WASSET`

The service completed successfully. Resource wait mode was previously disabled.

`$SETSHLV`

Set Automatic Unshelving — Controls whether a process automatically unshelves files.

Format

```
SYS$SETSHLV [pidadr] , [prcnam] , [shlvflg]
```

C Prototype

```
int sys$setshlv
    (unsigned int *pidadr, void *prcnam, unsigned int shlvflg);
```

Arguments

`pidadr`

OpenVMS usage: `process_id`
type: `longword (unsigned)`

access: modify
mechanism: by reference

Process identification (PID) of the process. The *pidadr* argument is the address of the PID. The *pidadr* argument can only refer to a process running on the local node. You cannot modify a process on a remote node.

You must specify the *pidadr* argument to modify a process whose UIC group number is different from that of the calling process.

prcnam

OpenVMS usage: process_name
type: character-coded text string
access: read only
mechanism: by descriptor-fixed length string descriptor

Process name of the process. The *prcnam* argument is the address of a character string descriptor pointing to the process name. You identify a process with a 1- to 15-character string.

You can only use the *prcnam* argument to modify a process in the same UIC group as the calling process. To modify a process in another UIC group, you must specify the *pidadr* argument.

shlvflg

OpenVMS usage: longword_unsigned
type: longword (unsigned)
access: read only
mechanism: by value

Value specifying whether automatic unshelving is to be turned on or off. The *shlvflg* argument is a longword containing this value. The value 0 turns automatic unshelving on. The value 1 turns automatic unshelving off.

Description

The Set Automatic Unshelving service controls whether a process automatically unshelves files.

The *pidadr* and *prcnam* default to the current process. If the longword at address *pidadr* is 0, the PID of the target process is returned.

The setting for automatic unshelving is inherited by subprocesses.

The DCL command SET PROCESS/[NO]AUTOUNSHELVE also controls automatic unshelving for a process; refer to the *VSI OpenVMS DCL Dictionary* for details.

Required Access or Privileges

Depending on the operation, the calling process might need one of the following privileges to use \$SETSHLV:

- GROUP privilege to modify a process in the same group, unless the target process has the same UIC as the calling process.

- WORLD privilege to modify any process in the system.

Required Quota

None

Related Services

\$GETJPI

Condition Values Returned

SS\$_WASCLR

The service completed successfully. Automatic unshelving was previously on.

SS\$_WASSET

The service completed successfully. Automatic unshelving was previously off.

SS\$_ACCVIO

An argument was not accessible by the caller.

SS\$_BADPARAM

The *shlvflg* argument was invalid.

SS\$_IVLOGNAM

The *prcnam* argument was invalid. The process name string had either 0 characters or more than 15 characters.

SS\$_NONEXPR

The specified process did not exist, or the specified process identification was invalid.

SS\$_NOPRIV

The caller did not have the privilege to modify other processes.

SS\$_REMOTE_PROC

The specified process was not on the local node. The service cannot modify a process on a remote node.

\$SETSTK

Set Stack Limits — Allows a process to change the size of its supervisor, executive, and kernel stacks by altering the values in the stack limit for a memory stack and base arrays held in P1 (per-process) space.

Format

```
SYS$SETSTK inadr , [retadr] , [acmode]
```

C Prototype

```
int sys$setstk
    (struct _va_range *inadr, struct _va_range *retadr, unsigned int
    acmode);
```

Arguments

inadr

OpenVMS usage: address_range
type: longword (unsigned)
access: read only
mechanism: by reference

Range of addresses that express the stack's new limits. The *inadr* argument is the address of a 2-longword array containing, in order, the address of the top of the stack and the address of the base of the stack. Because stacks in P1 space expand from high to low addresses, the address of the base of the stack must be greater than the address of the top of the stack.

retadr

OpenVMS usage: address_range
type: longword (unsigned)
access: write only
mechanism: by reference

Range of addresses that express the stack's previous limits. The *retadr* argument is the address of a 2-longword array into which \$SETSTK writes, in the first longword, the previous address of the top of the stack and, in the second longword, the previous address of the base of the stack.

acmode

OpenVMS usage: access_mode
type: longword (unsigned)
access: read only
mechanism: by value

Access mode of the stack to be altered. The *acmode* argument is a longword containing the access mode. The \$PSLDEF macro defines symbols for the four access modes. The most privileged access mode used is the access mode of the caller.

If *acmode* specifies user mode, \$SETSTK performs no operation and returns the SSS_NORMAL condition value.

Description

The Set Stack Limits service allows a process to change the size of its supervisor, executive, and kernel stacks by altering the values in the stack limit and base arrays held in P1 (per-process) space.

Required Access or Privileges

The calling process can adjust the size of stacks only for access modes that are equal to or less privileged than the access mode of the calling process.

Required Quota

None

Related Services

\$ADJSTK, \$ADJWSL, \$CRETVA, \$CRMPSC, \$DELTVA, \$DGBLSC, \$EXPREG, \$LCKPAG, \$LKWSET, \$MGBLSC, \$PURGWS, \$SETPRT, \$SETSWM, \$ULKPAG, \$ULWSET, \$UPDSEC, \$UPDSECW

Condition Values Returned

SS\$_NORMAL

The service completed successfully.

SS\$_ACCVIO

The input address array cannot be read by the caller; the input range is invalid; or the return address array cannot be written by the caller.

\$SETSTK_64 (Alpha and Integrity servers)

Set Stack Limits — On Alpha and Integrity server systems, allows a process to change the size of its supervisor, executive, and kernel stacks by altering the values in the stack limit for a memory stack or a register stack and base arrays held in P1 (per-process) space.

Format

```
SYSSSETSTK_64
    start_va_64 , length_64 , acmode, flags, prev_start_va, prev_length
```

C Prototype

```
int sys$setstk_64
    (void *start_va_64, unsigned __int64 length_64, unsigned int acmode,
     unsigned int flags, void ** prev_start_va_64,
     unsigned __int64 * prev_length_64);
```

Arguments

start_va_64

OpenVMS usage: address
type: quadword address
access: read only

mechanism: by value

Lowest address in range of addresses that express the stack's new limits. For a memory stack, this address is the stack limit. For an Integrity servers register stack, this address is the stack base.

length_64

OpenVMS usage: length
type: quadword (unsigned)
access: read only
mechanism: by value

Length of the range of addresses that express the stack's new limits.

acmode

OpenVMS usage: access_mode
type: longword (unsigned)
access: read only
mechanism: by value

Access mode of the stack to be altered. The *acmode* argument is a longword containing the access mode. The \$PSLDEF macro defines symbols for the four access modes. The most privileged access mode used is the access mode of the caller.

If *acmode* specifies user mode, \$SETSTK_64 performs no operation and returns the SS\$_NORMAL condition value.

flags

OpenVMS usage: mask_longword
type: longword (unsigned)
access: read only
mechanism: by value

0 for memory stack (Alpha and Integrity servers VA\$_M_SETSTK_REGISTER for register stack (Integrity servers only)

The \$VADEF macro and VADEF.H file define symbolic names for the *flags* argument.

prev_start_va_64

OpenVMS usage: address
type: quadword address
access: write only
mechanism: by reference

Lowest address in the range of addresses that express the stack's previous limits. For a memory stack, this address was the stack limit. For an Integrity servers register stack, this address was the stack base.

prev_length_64

OpenVMS usage: length
type: quadword
access: write only
mechanism: by reference

Length of the range of addresses that express the stack's previous limits.

Description

The Set Stack Limits service allows a process to change the size of its supervisor, executive, and kernel stacks by altering the values in the stack limit and base arrays held in P1 (per-process) space. For Alpha, only the memory stack limits can be changed. The address range must be within 32-bit address space. For IA64, either the memory stack or register stack limits can be changed. The address range for the register stack can be in 64-bit address space.

Required Access or Privileges

The calling process can adjust the size of stacks only for access modes that are equal to or less privileged than the access mode of the calling process.

Required Quota

None

Related Services

\$ADJSTK, \$ADJWSL, \$CRETVA_64, \$DELTVA_64, \$DGBLSC, \$EXPREG_64, \$LCKPAG_64, \$LKWSET_64, \$MGBLSC_64, \$PURGWS, \$SETPRT_64, \$SULKPAG_64, \$SULWSET_64, \$UPDSEC_64, \$UPDSECW_64

Condition Values Returned

SS\$_NORMAL

The service completed successfully.

SS\$_ACCVIO

The prev_start_va_64 or prev_length_64 argument cannot be written by the caller.

SS\$_LENVIO

Memory stack limits were specified in 64-bit address space. Only 32-bit addresses are supported for the memory stack limits.

\$SETSWM

Set Process Swap Mode — Allows a process to control whether it can be swapped out of the balance set.

Format

`SYS$SETSWM [swpflg]`

C Prototype

```
int sys$setswm (char swpflg);
```

Argument

swpflg

OpenVMS usage: longword_unsigned
type: longword (unsigned)
access: read only
mechanism: by value

Indicator specifying whether the process can be swapped. The *swpflg* argument is a longword value. The value 0 (the default) enables process swap mode, meaning the process can be swapped. The value 1 disables process swap mode, meaning the process cannot be swapped.

Description

The Set Process Swap Mode service allows a process to control whether it can be swapped out of the balance set.

When the process swap mode is enabled, the process can be swapped out; when disabled, the process remains in the balance set until (1) process swap mode is reenabled or (2) the process is deleted.

The \$SETSWM service returns a condition value indicating whether process swap mode was enabled or disabled prior to the call to \$SETSWM.

Required Access or Privileges

To change its process swap mode, the calling process must have PSWAPM privilege.

Required Quota

None

Related Services

\$ADJSTK, \$ADJWSL, \$CRETVA, \$CRMPSC, \$DELTVA, \$DGBLSC, \$EXPREG, \$LCKPAG, \$LKWSET, \$MGBLSC, \$PURGWS, \$SETPRT, \$SETSTK, \$ULKPAG, \$ULWSET, \$UPDSEC, \$UPDSECW

To lock some but not necessarily all process pages into the balance set, use the Lock Pages in Memory (\$LCKPAG) service.

For more information, see the chapter on memory management in the *VSI OpenVMS Programming Concepts Manual*.

Condition Values Returned

SS\$_WASCLR

The service completed successfully. The process was not previously locked in the balance set.

SS\$_WASSET

The service completed successfully. The process was previously locked in the balance set.

SS\$_NOPRIV

The process does not have the necessary PSWAPM privilege.

\$SETUAI

Set User Authorization Information — Modifies the user authorization file (UAF) record for a specified user.

Format

```
SYSS$SETUAI  
    [nullarg] , [contxt] , usrn timer , [nullarg] , [nullarg] , [nullarg]
```

C Prototype

```
int sys$setuai  
    (unsigned int efn, unsigned int *contxt, void *usrnam, void *itmlst,  
     struct _iosb *iosb, void (*astadr)(__unknown_params), int astprm);
```

Arguments

nullarg

OpenVMS usage: null_arg
type: longword (unsigned)
access: read only
mechanism: by value

Placeholder argument reserved to OpenVMS.

contxt

OpenVMS usage: longword
type: longword (unsigned)
access: modify
mechanism: by reference

A longword used to maintain authorization file context. The *contxt* argument is the address of a longword to receive a \$SETUAI context value. On the initial call, this longword should contain the value

–1. On subsequent calls, the value of the *ctxt* argument from the previous call should be passed back in.

usrnam

OpenVMS usage: char_string
 type: character-coded text string
 access: read only
 mechanism: by descriptor-fixed length string descriptor

Name of the user whose UAF record is modified. The *usrnam* argument is the address of a descriptor pointing to a character text string containing the user name. The user name string can contain a maximum of 32 alphanumeric characters.

itmlst

OpenVMS usage: item_list_3
 type: longword (unsigned)
 access: read only
 mechanism: by reference

Item list specifying which information from the specified UAF record is to be modified. The *itmlst* argument is the address of a list of one or more item descriptors, each of which specifies an item code. The item list is terminated by the item code 0 or by the longword 0.

The following diagram depicts the format of a single item descriptor.

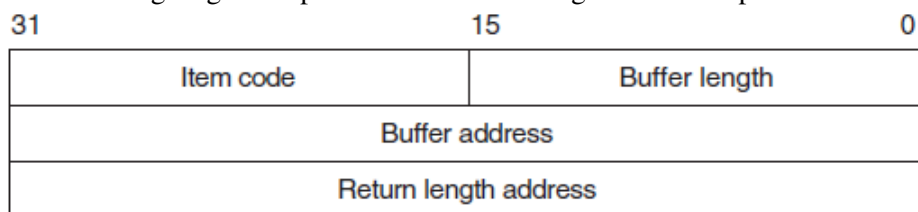

ZK-5186A-GE

The following table defines the item descriptor fields.

Descriptor Field	Definition
Buffer length	A word specifying the length (in bytes) of the buffer in which \$SETUAI is to write the information. The length of the buffer varies, depending on the item code specified in the item code field of the item descriptor, and is given in the description of each item code. If the value of the buffer length field is too small, \$SETUAI truncates the data.
Item code	A word containing a user-supplied symbolic code specifying the item of information that \$SETUAI is to set. The \$UAIDEF macro defines these codes.
Buffer address	A longword address of the buffer that specifies the information to be set by \$SETUAI.
Return length address	A longword containing the user-supplied address of a word in which \$SETUAI writes the length in bytes of the information it actually set.

The symbolic codes have the following format:

UAI\$_code

nullarg

OpenVMS usage: nullarg
type: quadword (unsigned)
access: write only
mechanism: by reference

Placelholding argument reserved to OpenVMS.

nullarg

OpenVMS usage: nullarg
type: procedure entry mask
access: call without stack unwinding
mechanism: by reference

Placelholding argument reserved to OpenVMS.

nullarg

OpenVMS usage: nullarg
type: longword (unsigned)
access: read only
mechanism: by value

Placelholding argument reserved to OpenVMS.

Item Codes

UAI\$_ACCOUNT

When you specify UAI\$_ACCOUNT, \$SETUAI sets, as a blank-padded 32-character string, the account name of the user.

An account name can include up to 8 characters. Because the account name is a blank-filled string, however, the buffer length field of the item descriptor should specify 32 (bytes).

UAI\$_ASTLM

When you specify UAI\$_ASTLM, \$SETUAI sets the AST queue limit.

Because this decimal number is a word in length, the buffer length field in the item descriptor should specify 2 (bytes).

UAI\$_BATCH_ACCESS_P

When you specify UAI\$_BATCH_ACCESS_P, \$SETUAI sets, as a 3-byte value, the range of times during which batch access is permitted for primary days. Each bit set represents a 1-hour period, from bit 0 as midnight to 1 a.m., to bit 23 as 11 p.m. to midnight.

The buffer length field in the item descriptor should specify 3 (bytes).

UAI\$_BATCH_ACCESS_S

When you specify UAI\$_BATCH_ACCESS_S, \$SETUAI sets, as a 3-byte value, the range of times during which batch access is permitted for secondary days. Each bit set represents a 1-hour period, from bit 0 as midnight to 1 a.m., to bit 23 as 11 p.m. to midnight.

The buffer length field in the item descriptor should specify 3 (bytes).

UAI\$_BIOLM

When you specify UAI\$_BIOLM, \$SETUAI sets the buffered I/O count limit.

Because this decimal number is a word in length, the buffer length field in the item descriptor should specify 2 (bytes).

UAI\$_BYTLM

When you specify UAI\$_BYTLM, \$SETUAI sets the buffered I/O byte limit.

Because the buffered I/O count limit is a longword decimal number, the buffer length field in the item descriptor should specify 4 (bytes).

UAI\$_CLITABLES

When you specify UAI\$_CLITABLES, \$SETUAI sets, as a character string, the name of the user-defined CLI table for the account, if any.

Because the CLI table name can include up to 31 characters plus a size-byte prefix, the buffer length field of the item descriptor should specify 32 (bytes).

UAI\$_CPUTIM

When you specify UAI\$_CPUTIM, \$SETUAI sets the maximum CPU time limit (per session) for the process in 10-millisecond units.

Because the maximum CPU time limit is a longword decimal number, the buffer length field in the item descriptor should specify 4 (bytes).

UAI\$_DEFCLI

When you specify UAI\$_DEFCLI, \$SETUAI sets, as an OpenVMS RMS file name component, the name of the command language interpreter used to execute the specified batch job. The file specification set assumes the device name and directory SYS\$SYSTEM and the file type .EXE.

Because a file name can include up to 31 characters plus a size-byte prefix, the buffer length field in the item descriptor should specify 32 (bytes).

UAI\$_DEFDEV

When you specify UAI\$_DEFDEV, \$SETUAI sets, as a 1- to 31-character string, the name of the default device.

Because the device name string can include up to 31 characters plus a size-byte prefix, the buffer length field in the item descriptor should specify 32 (bytes).

UAI\$_DEFDIR

When you specify `UAI$_DEFDIR`, `$SETUAI` sets, as a 1- to 63-character string, the name of the default directory.

Because the directory name string can include up to 63 characters plus a size-byte prefix, the buffer length field in the item descriptor should specify 64 (bytes).

UAI\$_DEF_PRIV

When you specify `UAI$_DEF_PRIV`, `$SETUAI` sets, as a quadword value, the default privileges for the user.

Because the default privileges are set as a quadword value, the buffer length field in the item descriptor should specify 8 (bytes).

UAI\$_DFWSCNT

When you specify `UAI$_DFWSCNT`, `$SETUAI` sets, pagelets (on Alpha and Integrity server systems), the default working set size.

Because the default working set size is a longword decimal number, the buffer length field in the item descriptor should specify 4 (bytes).

UAI\$_DIALUP_ACCESS_P

When you specify `UAI$_DIALUP_ACCESS_P`, `$SETUAI` sets, as a 3-byte value, the range of times during which dialup access is permitted for primary days. Each bit set represents a 1-hour period, from bit 0 as midnight to 1 a.m., to bit 23 as 11 p.m. to midnight.

The buffer length field in the item descriptor should specify 3 (bytes).

UAI\$_DIALUP_ACCESS_S

When you specify `UAI$_DIALUP_ACCESS_S`, `$SETUAI` sets, as a 3-byte value, the range of times during which dialup access is permitted for secondary days. Each bit set represents a 1-hour period, from bit 0 as midnight to 1 a.m., to bit 23 as 11 p.m. to midnight.

The buffer length field in the item descriptor should specify 3 (bytes).

UAI\$_DIOLM

When you specify `UAI$_DIOLM`, `$SETUAI` sets the direct I/O count limit.

Because this decimal number is a word in length, the buffer length field in the item descriptor should specify 2 (bytes).

UAI\$_ENCRYPT

When you specify `UAI$_ENCRYPT`, `$SETUAI` sets one of the values shown in the following table to identify the encryption algorithm for the primary password.

Symbolic Name	Description
<code>UAI\$_AD_II</code>	Uses a CRC algorithm and returns a longword hash value. It was used in VAX/VMS releases prior to Version 2.0.
<code>UAI\$_PURDY</code>	Uses a Purdy algorithm over salted input. It expects a blank-padded user name and returns a quadword hash value. This algorithm was used during VAX/VMS Version 2.0 field test.

Symbolic Name	Description
UAI\$C_PURDY_V	Uses the Purdy algorithm over salted input. It expects a variable length user name and returns a quadword hash value. This algorithm was used in VMS releases prior to Version 5.4.
UAI\$C_PURDY_S	Uses the Purdy algorithm over salted input. It expects a variable length user name and returns a quadword hash value. This is the current algorithm that the operating system uses for all new password changes.
UAI\$C_PREFERED_ALGORITHM	Represents the latest encryption algorithm that the operating system uses to encrypt new passwords. Currently, it equates to UAI\$C_PURDY_S. VSI recommends that you use this symbol in source modules.

Because the encryption algorithm is a byte in length, the buffer length field in the item descriptor should specify 1 (byte).

UAI\$_ENCRYPT2

When you specify UAI\$_ENCRYPT2, \$SETUAI sets one of the following values, indicating the encryption algorithm for the secondary password. Refer to the UAI\$_ENCRYPT item code for a description of the algorithms.

UAI\$C_AD_II
 UAI\$C_PURDY
 UAI\$C_PURDY_V
 UAI\$C_PURDY_S
 UAI\$C_PREFERED_ALGORITHM

UAI\$_ENQLM

When you specify UAI\$_ENQLM, \$SETUAI sets the lock queue limit.

Because this decimal number is a word in length, the buffer length field in the item descriptor should specify 2 (bytes).

UAI\$_EXPIRATION

When you specify UAI\$_EXPIRATION, \$SETUAI sets, as a quadword absolute time value, the expiration date and time of the account.

Because the absolute time value is a quadword in length, the buffer length field in the item descriptor should specify 8 (bytes).

UAI\$_FILLM

When you specify UAI\$_FILLM, \$SETUAI sets the open file limit.

Because this decimal number is a word in length, the buffer length field in the item descriptor should specify 2 (bytes).

UAI\$_FLAGS

When you specify UAI\$_FLAGS, \$SETUAI sets, as a longword bit vector, the various login flags set for the user.

Each flag is represented by a bit. The \$UAIDEF macro defines the following symbolic names for these flags.

Symbol	Description
UAI\$V_AUDIT	All actions are audited.
UAI\$V_AUTOLOGIN	User can only log in to terminals defined by the Automatic Login facility (ALF).
UAI\$V_CAPTIVE	User is restricted to captive account.
UAI\$V_DEFCLI	User is restricted to default command interpreter.
UAI\$V_DISACNT	User account is disabled.
UAI\$V_DISCTLY	User cannot use Ctrl/Y.
UAI\$V_DISFORCE_PWD_CHANGE	User will not be forced to change expired passwords at login.
UAI\$V_DISIMAGE	User cannot issue the RUN or MCR commands or use the foreign command mechanism in DCL.
UAI\$V_DISMAIL	Announcement of new mail is suppressed.
UAI\$V_DISPWDDIC	Automatic checking of user-selected passwords against the system dictionary is disabled.
UAI\$V_DISPWDHIS	Automatic checking of user-selected passwords against previously used passwords is disabled.
UAI\$V_DISPWDSYNCH	When set, prevents synchronizing a user's SYSUAF.DAT password using an external authentication password (when UAI\$V_EXTAUTH is set).
UAI\$V_DISRECONNECT	User cannot reconnect to existing processes.
UAI\$V_DISREPORT	User will not receive last login messages.
UAI\$V_DISWELCOME	User will not receive the login welcome message.
UAI\$V_EXTAUTH	User is considered externally authenticated by an external user ID and password and not by the SYSUAF user name and password. The SYSUAF record is still used for checking login restrictions and quotas and for creating the user's OpenVMS process profile.
UAI\$V_GENPWD	User is required to use generated passwords.
UAI\$V_LOCKPWD	SET PASSWORD command is disabled.
UAI\$V_MIGRATEPWD	User's SYSUAF password was set using AUTHORIZE or SYS\$SETUAI and is likely to be inconsistent with the user's external user password. If password migration is enabled, the system will attempt to update external authorization service the next time the user attempts a login.
UAI\$V_NOMAIL	Mail delivery to user is disabled.
UAI\$V_PWD_EXPIRED	Primary password is expired.
UAI\$V_PWD2_EXPIRED	Secondary password is expired.
UAI\$V_PWDMIX	Enables case-sensitive and extended-character passwords. After PWDMIX is specified, you can then use mixed-case and extended characters in passwords. Be aware that before the PWDMIX flag is enabled, the system stores passwords

Symbol	Description
	<p>in all upper-case. Therefore, until you change passwords, you must enter your pre-PWDMIX passwords in upper-case.</p> <p>To change the password after PWDMIX is enabled:</p> <ul style="list-style-type: none"> • A user can use the DCL command SET PASSWORD, specifying the new mixed-case password (omitting quotation marks). • A system manager can use the AUTHORIZE command MODIFY/PASSWORD, and enclose the user's new mixed-case password in quotation marks " ".
UAI\$_RESTRICTED	User is limited to operating under a restricted account. Clear the CAPTIVE flag (UAI\$_CAPTIVE), if set, before setting the RESTRICTED flag. (See the <i>VSI OpenVMS Guide to System Security</i>)
UAI\$_VMSAUTH	When set, the user is allowed to authenticate with the SYSUAF.DAT user name and password (when UAI\$_EXTAUTH is set).

UAI\$_JTQUOTA

When you specify UAI\$_JTQUOTA, \$SETUAI sets the initial byte quota with which the jobwide logical name table is to be created.

Because this quota is a longword decimal number, the buffer length field in the item descriptor should specify 4 (bytes).

UAI\$_LASTLOGIN_I

When you specify UAI\$_LASTLOGIN_I, \$SETUAI sets, as a quadword absolute time value, the date of the last interactive login.

UAI\$_LASTLOGIN_N

When you specify UAI\$_LASTLOGIN_N, \$SETUAI sets, as a quadword absolute time value, the date of the last noninteractive login.

UAI\$_LGICMD

When you specify UAI\$_LGICMD, \$SETUAI sets, as an OpenVMS RMS file specification, the name of the default login command file.

Because a file specification can include up to 63 characters plus a size-byte prefix, the buffer length field of the item descriptor should specify 64 (bytes).

UAI\$_LOCAL_ACCESS_P

When you specify UAI\$_LOCAL_ACCESS_P, \$SETUAI sets, as a 3-byte value, the range of times during which local interactive access is permitted for primary days. Each bit set represents a 1-hour period, from bit 0 as midnight to 1 a.m., to bit 23 as 11 p.m. to midnight.

The buffer length field in the item descriptor should specify 3 (bytes).

UAI\$_LOCAL_ACCESS_S

When you specify `UAI$_LOCAL_ACCESS_S`, `$SETUAI` sets, as a 3-byte value, the range of times during which local interactive access is permitted for secondary days. Each bit set represents a 1-hour period, from bit 0 as midnight to 1 a.m., to bit 23 as 11 p.m. to midnight.

The buffer length field in the item descriptor should specify 3 (bytes).

UAI\$_LOGFAILS

When you specify `UAI$_LOGFAILS`, `$SETUAI` sets the count of login failures.

Because this decimal number is a word in length, the buffer length field in the item descriptor should specify 2 (bytes).

UAI\$_MAXACCTJOBS

When you specify `UAI$_MAXACCTJOBS`, `$SETUAI` sets the maximum number of batch, interactive, and detached processes that can be active at one time for all users of the same account. The value 0 represents an unlimited number.

Because this decimal number is a word in length, the buffer length field in the item descriptor should specify 2 (bytes).

UAI\$_MAXDETACH

When you specify `UAI$_MAXDETACH`, `$SETUAI` sets the detached process limit. The value 0 represents an unlimited number.

Because this decimal number is a word in length, the buffer length field in the item descriptor should specify 2 (bytes).

UAI\$_MAXJOBS

When you specify `UAI$_MAXJOBS`, `$SETUAI` sets the active process limit. A value of 0 represents an unlimited number.

Because this decimal number is a word in length, the buffer length field in the item descriptor should specify 2 (bytes).

UAI\$_NETWORK_ACCESS_P

When you specify `UAI$_NETWORK_ACCESS_P`, `$SETUAI` sets, as a 3-byte value, the range of times during which network access is permitted for primary days. Each bit set represents a 1-hour period, from bit 0 as midnight to 1 a.m., to bit 23 as 11 p.m. to midnight.

The buffer length field in the item descriptor should specify 3 (bytes).

UAI\$_NETWORK_ACCESS_S

When you specify `UAI$_NETWORK_ACCESS_S`, `$SETUAI` sets, as a 3-byte value, the range of times during which network access is permitted for secondary days. Each bit set represents a 1-hour period, from bit 0 as midnight to 1 a.m., to bit 23 as 11 p.m. to midnight.

The buffer length field in the item descriptor should specify 3 (bytes).

UAI\$_OWNER

When you specify UAI\$_OWNER, \$SETUAI sets, as a character string, the name of the owner of the account.

Because the owner name can include up to 31 characters plus a size-byte prefix, the buffer length field of the item descriptor should specify 32 (bytes).

UAI\$_PASSWORD

When you specify UAI\$_PASSWORD, \$SETUAI sets the specified plaintext string as the primary password for the user and updates the primary password change date. You must have SYSPRV privilege to set passwords for any user account (including your own).

The UAI\$_PASSWORD and UAI\$_PASSWORD2 item codes provide the building blocks for designing a site-specific SET PASSWORD utility. Note that if you create such a utility, you should also set the LOCKPWD bit in the user authorization file (UAF) to prevent users from using the DCL command SET PASSWORD and to prevent the LOGINOUT process from forcing password changes. If you create a site-specific SET PASSWORD utility, install the utility with SYSPRV privilege.

You must adhere to the following guidelines when specifying a password with UAI\$_PASSWORD or UAI\$_PASSWORD2:

- The password must meet the minimum password length defined for the user account.
- The password cannot exceed 32 characters in length.
- The password must be different from the previous password.

To clear the primary password, specify the value 0 in the buffer length field.

When you use \$SETUAI to change the password on an account that has the UAI\$V_EXTHAUTH flag set, the UAI\$V_MIGRATEPWD flag is set automatically.

Note

If you specify UAI\$_PASSWORD, the UAI\$_PWD_DATE item is ignored. To use these two item codes, you must use them in two separate calls.

To generate a pre-expired password, follow the instructions in the "Description" section at the end of this system service documentation."

UAI\$_PASSWORD2

Sets the specified plaintext string as the secondary password for the user and updates the secondary password change date. You must have SYSPRV privilege to set passwords for any user account (including your own).

To clear the secondary password, specify the value 0 in the buffer length field.

Note

If you specify UAI\$_PASSWORD2, the UAI\$_PWD2_DATE item is ignored. To use these two item codes, you must use them in two separate calls.

To generate a pre-expired password, follow the instructions in the "Description" section at the end of this system service documentation.

UAI\$_PBYTLM

When you specify UAI\$_PBYTLM, \$SETUAI Sets, in pagelets (on Alpha and Integrity server systems), the paging file quota.

Because the paging file quota is a longword decimal number, the buffer length field in the item descriptor should specify 4 (bytes).

UAI\$_PGFLQUOTA

When you specify UAI\$_PGFLQUOTA, \$SETUAI sets, in pages (on VAX systems) or pagelets (on Alpha systems), the paging file quota.

Because the paging file quota is a longword decimal number, the buffer length field in the item descriptor should specify 4 (bytes).

UAI\$_PRCNT

When you specify UAI\$_PRCNT, \$SETUAI sets the subprocess creation limit.

Because this decimal number is a word in length, the buffer length field in the item descriptor should specify 2 (bytes).

UAI\$_PRI

When you specify UAI\$_PRI, \$SETUAI sets the default base priority.

Because this decimal number is a byte in length, the buffer length field in the item descriptor should specify 1 (byte).

UAI\$_PRIMEDAYS

When you specify UAI\$_PRIMEDAYS, \$SETUAI sets, as a byte bit vector, the primary and secondary days of the week.

Each bit represents a day of the week, with the bit clear representing a primary day and the bit set representing a secondary day. The \$UAIDEF macro defines the following symbolic names for these bits:

UAI\$V_MONDAY
UAI\$V_TUESDAY
UAI\$V_WEDNESDAY
UAI\$V_THURSDAY
UAI\$V_FRIDAY
UAI\$V_SATURDAY
UAI\$V_SUNDAY

UAI\$_PRIV

When you specify UAI\$_PRIV, \$SETUAI sets, as a quadword value, the names of the privileges that the user holds.

Because the privileges are set as a quadword value, the buffer length field in the item descriptor should specify 8 (bytes).

UAI\$_PWD

When you specify `UAI$_PWD`, `$SETUAI` sets, as a quadword value, the hashed primary password of the user.

Because the hashed primary password is set as a quadword value, the buffer length field in the item descriptor should specify 8 (bytes).

When you use `$SETUAI` to change the password on an account that has the `UAI$_V_EXTHAUTH` flag set, the `UAI$_MIGRATEPWD` flag is set automatically.

UAI\$_PWD_DATE

When you specify `UAI$_PWD_DATE`, `$SETUAI` sets, as a quadword absolute time value, the date of the last password change.

Because this value is a quadword in length, the buffer length field in the item descriptor should specify 8 (bytes).

A value of `-1` indicates that the password could be marked as preexpired.

Note

If you specify `UAI$_PASSWORD`, the `UAI$_PWD_DATE` item is ignored. To use these two item codes, you must use them in two separate calls.

To generate a pre-expired password, follow the instructions in the "Description" section at the end of this system service documentation.

UAI\$_PWD_LENGTH

When you specify `UAI$_PWD_LENGTH`, `$SETUAI` sets the minimum password length.

Because this decimal number is a byte in length, the buffer length field in the item descriptor should specify 1 (byte).

UAI\$_PWD_LIFETIME

When you specify `UAI$_PWD_LIFETIME`, `$SETUAI` sets, as a quadword delta time value, the password lifetime.

Because this value is a quadword in length, the buffer length field in the item descriptor should specify 8 (bytes).

A quadword of 0 means that none of the password mechanisms will take effect.

UAI\$_PWD2

When you specify `UAI$_PWD2`, `$SETUAI` sets, as a quadword value, the hashed secondary password of the user.

Because the hashed secondary password is set as a quadword value, the buffer length field in the item descriptor should specify 8 (bytes).

UAI\$_PWD2_DATE

When you specify `UAI$_PWD2_DATE`, `$SETUAI` sets, as a quadword absolute time value, the last date the secondary password was changed.

Because this value is a quadword in length, the buffer length field in the item descriptor should specify 8 (bytes).

A value of `-1` indicates that the password could be marked as preexpired.

UAI\$_QUEPRI

When you specify `UAI$_QUEPRI`, `$SETUAI` sets the maximum job queue priority in the range 0 through 31.

Because this decimal number is a byte in length, the buffer length field in the item descriptor should specify 1 (byte).

UAI\$_REMOTE_ACCESS_P

When you specify `UAI$_REMOTE_ACCESS_P`, `$SETUAI` sets, as a 3-byte value, the range of times during which batch access is permitted for primary days. Each bit set represents a 1-hour period, from bit 0 as midnight to 1 a.m., to bit 23 as 11 p.m. to midnight.

The buffer length field in the item descriptor should specify 3 (bytes).

UAI\$_REMOTE_ACCESS_S

When you specify `UAI$_REMOTE_ACCESS_S`, `$SETUAI` sets, as a 3-byte value, the range of times during which batch access is permitted for secondary days. Each bit set represents a 1-hour period, from bit 0 as midnight to 1 a.m., to bit 23 as 11 p.m. to midnight.

The buffer length field in the item descriptor should specify 3 (bytes).

UAI\$_SALT

When you specify `UAI$_SALT`, `$SETUAI` sets the salt field of the user's record to the value you provide. The salt value is used in the operating system hash algorithm to generate passwords. `$SETUAI` does not generate a new salt value for you.

Because this decimal number is a word in length, the buffer length field in the item descriptor should specify 2 (bytes).

By copying the item codes `UAI$_SALT`, `UAI$_ENCRYPT`, `UAI$_PWD`, `UAI$_PWD_DATE`, and `UAI$_FLAGS`, a site-security administrator can construct a utility that propagates password changes throughout the network. Note, however, that VSI does not recommend using the same password on more than one node in a network.

UAI\$_SHRFILLM

When you specify `UAI$_SHRFILLM`, `$SETUAI` sets the shared file limit.

Because this decimal number is a word in length, the buffer length field in the item descriptor should specify 2 (bytes).

UAI\$_TQCNT

When you specify `UAI$_TQCNT`, `$SETUAI` sets the timer queue entry limit.

Because this decimal number is a word in length, the buffer length field in the item descriptor should specify 2 (bytes).

UAI\$_UIC

When you specify UAI\$_UIC, \$SETUAI sets, as a longword, the user identification code (UIC). For the format of the UIC, see the *VSI OpenVMS Guide to System Security*.

UAI\$_USER_DATA

When you specify UAI\$_USER_DATA, \$SETUAI sets up to 255 bytes of information in the user data area of the system user authorization file (SYSUAF). This is the supported method for modifying the user data area of the SYSUAF. VSI no longer supports direct user modification of the SYSUAF.

To clear all the information in the user data area of the SYSUAF, specify \$SETUAI with a buffer length field of 0.

UAI\$_WSEXTENT

When you specify UAI\$_WSEXTENT, \$SETUAI sets the working set extent, in pagelets (on Alpha and Integrity server systems), specified for the specified job or queue.

Because the working set extent is a longword decimal number, the buffer length field in the item descriptor should specify 4 (bytes).

UAI\$_WSQUOTA

When you specify UAI\$_WSQUOTA, \$SETUAI sets the working set quota, in pagelets (on Alpha and Integrity server systems), for the specified user.

Because the working set quota is a longword decimal number, the buffer length field in the item descriptor should specify 4 (bytes).

Description

The Set User Authorization Information service is used to modify the user authorization file (UAF) record for a specified user.

The UAI\$V_PWD_EXPIRED should only be set when the bit UAI\$V_DISFORCE_PWD_CHANGE is set in the user's SYSUAF record and the comparison between the UAI\$_PWD_DATE and UAI\$_PWD_LIFETIME indicates a password is past its valid life.

To generate a pre-expired password, first generate a new hashed password using \$HASH_PASSWORD. Then make a call to \$SETUAI using either UAI\$_PASSWORD or UAI\$_PASSWORD2, as appropriate. Finally, make a separate call to \$SETUAI to set UAI\$_PWD_DATE or UAI\$_PWD_DATE2 to -1.

For information about login and password expiration, see the Description section of the \$GETUAI system service.

Required Access or Privileges

The following list describes the privileges you need to use the \$SETUAI service:

- **BYPASS** or **SYSPRV**—Allows modification of any record in the UAF (user authorization file).

- **GRPPRV**—Allows modification of any record in the UAF whose UIC group matches that of the requester. Note, however, that you cannot change a UAF record whose UIC matches exactly the requester's UIC. Group managers with GRPPRV privilege are limited in the extent to which they can modify the UAF records of users in the same group; values such as privileges and quotas can be changed only if the modification does not exceed the values set in a group manager's UAF record.
- **No privilege**—Does not allow access to any UAF record.

Required Quota

None

Related Services

\$GETUAI

Condition Values Returned

SS\$_NORMAL

The service completed successfully.

SS\$_ACCVIO

The item list or input buffer cannot be read by the caller; or the return length buffer, output buffer, or status block cannot be written by the caller.

SS\$_BADPARAM

The function code is invalid; the item list contains an invalid item code; a buffer descriptor has an invalid length; or the reserved parameter has a nonzero value.

SS\$_NOGRPPRV

The user does not have the privileges required to modify the authorization information for other members of the UIC group.

SS\$_NOSYSPRV

The user does not have the privileges required to modify the authorization information associated with the user or for users outside of the user's UIC group.

RMS\$_RSZ

The UAF record is smaller than required; the caller's SYSUAF is likely corrupt.

This service can also return OpenVMS RMS status codes associated with operations on indexed files. For a description of RMS status codes that are returned by this service, refer to the *VSI OpenVMS Record Management Services Reference Manual*.

\$SETUP_AVOID_PREEMPT

Setup for Process Preemption Avoidance — Performs initial setup for process preemption avoidance.

Format

```
SYS$SETUP_AVOID_PREEMPT enable
```

C Prototype

```
int sys$setup_avoid_preempt (int enable);
```

Arguments

enable

OpenVMS usage: longword_unsigned
type: longword (unsigned)
access: read only
mechanism: by value

Enables or disables preemption avoidance. If the *enable* argument is set to 1, preemption avoidance is enabled; if 0, preemption avoidance is disabled.

Description

The Setup for Process Preemption Avoidance service is a kernel-mode initialization routine that locks the necessary internal data structures in memory so scheduling routines can access them above pageable IPL. A process or thread can then set or clear the indicator bit by calling the \$AVOID_PREEMPT service.

In addition, if the process or thread has ALTPRI privilege, \$SETUP_AVOID_PREEMPT sets a bit in the PKTA (a per-kernel-thread data area) to mark that the process or thread can prevent preemption by other processes or threads having the same base priority but not those that have a higher base priority.

Note that without ALTPRI, this service will still function successfully, but will only enable the \$AVOID_PREEMPT service to avoid preemptions due to quantum end.

Required Access or Privileges

None

Required Quota

None

Related Services

\$AVOID_PREEMPT

Condition Values Returned

SS\$_NORMAL

The service completed successfully.

Also, any values returned by the \$LKWSET or \$UNLKSET services.

\$SET_DEFAULT_TRANS

Set Default Transaction — Sets or clears the default transaction of the calling process.

Format

```
SYSS$SET_DEFAULT_TRANS
    [efn] , [flags] , iosb [, [astadr] , [astprm] , [new_tid] , [old_tid]]
```

C Prototype

```
int sys$set_default_trans
    (unsigned int efn, unsigned int flags, struct _iosb *iosb, ...);
```

Arguments

efn

OpenVMS usage: ef_number
 type: longword (unsigned)
 access: read only
 mechanism: by value

Number of the event flag that is set when the service completes. If this argument is omitted, event flag 0 is used.

flags

OpenVMS usage: mask_longword
 type: longword (unsigned)
 access: read only
 mechanism: by value

Flags specifying options for the service. The *flags* argument is a longword bit mask in which each bit corresponds to an option flag. The \$DDTMDEF macro defines symbolic names for the option flag, described in Table 11. All undefined bits must be 0. If this argument is omitted, no flags are used.

Table 11. \$SET_DEFAULT_TRANS Option Flag

Flag Name	Description
DDTM\$M_SYNC	Specifies successful synchronous completion by returning SS\$_SYNCH. When SS\$_SYNCH is returned, the AST routine is not called, the event flag is not set, and the I/O status block is not filled in.

iosb

OpenVMS usage: io_status_block
 type: quadword (unsigned)

access: write only
 mechanism: by reference

The I/O status block in which the completion status of the service is returned as a condition value. See the Condition Values Returned section.

The following diagram shows the structure of the I/O status block:

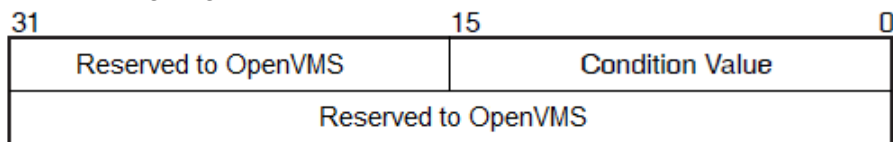

VM-0778A-AI

astadr

OpenVMS usage: ast_procedure
 type: procedure entry mask
 access: call without stack unwinding
 mechanism: by reference

The AST routine executed when the service completes, if SS\$_NORMAL is returned in R0. The *astadr* argument is the address of the entry mask of this routine. The routine is executed in the same access mode as that of the caller of the \$SET_DEFAULT_TRANS service.

astprm

OpenVMS usage: user_arg
 type: longword (unsigned)
 access: read only
 mechanism: by value

The AST parameter passed to the AST routine specified by the *astadr* argument.

new_tid

OpenVMS usage: trans_id
 type: octaword (unsigned)
 access: read only
 mechanism: by reference

The identifier (TID) of the new default transaction for the calling process. If this argument is zero (the default) or if it specifies a zero TID (an octaword of zeros), the service clears the default transaction of the calling process.

old_tid

OpenVMS usage:	trans_id
type:	octaword (unsigned)
access:	write only

mechanism:	by reference
------------	--------------

An octaword in which the service returns the identifier (TID) of the calling process' previous transaction (the one that was set or cleared by this call to `$SET_DEFAULT_TRANS`).

A zero TID is returned if the calling process did not have a default transaction prior to the call.

Description

The `$SET_DEFAULT_TRANS` system service:

- Sets or clears the default transaction of the calling process.

If either the `new_tid` argument passes the null value or the `new_tid` argument is omitted or zero, then the default transaction of the calling process is cleared. Otherwise the default transaction of the calling process is set to the value passed in the `new_tid` argument.

- Returns the identifier (TID) of the previous default transaction of the calling process (the one that was set or cleared by this call to `$SET_DEFAULT_TRANS`), if the `old_tid` argument is not zero.

`$SET_DEFAULT_TRANS` may fail for various reasons, including a call to `$START_TRANS` or `$START_BRANCH` that changes the default transaction of the calling process in progress.

Following a successful completion of `$SET_DEFAULT_TRANS`:

- The calling process does not have a default transaction, if either the `new_tid` argument passed the null value or the `new_tid` argument was omitted or zero.
- The default transaction of the calling process is that passed in the `new_tid` argument, if that argument was specified and its value was not zero.
- The identifier (TID) of the previous default transaction of the calling process is returned in the `old_tid` argument, if that argument was not omitted.

A null value is returned if the calling process did not previously have a default transaction.

There is also a wait form of the service, `$SET_DEFAULT_TRANSW`.

Required Privileges

None

Required Quotas

ASTLM

Related Services

`$ABORT_TRANS`, `$ABORT_TRANSW`, `$ACK_EVENT`, `$ADD_BRANCH`, `$ADD_BRANCHW`, `$CREATE_UID`, `$DECLARE_RM`, `$DECLARE_RMW`, `$END_BRANCH`, `$END_BRANCHW`, `$END_TRANS`, `$END_TRANSW`, `$FORGET_RM`, `$FORGET_RMW`, `$GETDTI`, `$GETDTIW`, `$GET_DEFAULT_TRANS`, `$JOIN_RM`, `$JOIN_RMW`, `$SETDTI`, `$SETDTIW`, `$SET_DEFAULT_TRANSW`, `$START_BRANCH`, `$START_BRANCHW`, `$START_TRANS`, `$START_TRANSW`, `$TRANS_EVENT`, `$TRANS_EVENTW`

Condition Values Returned

SS\$_NORMAL

If returned in R0, the request was successfully queued. If returned in the I/O status block, the service completed successfully.

SS\$_SYNCH

The service completed successfully and synchronously (returned only if the DDTM\$M_SYNC flag is set).

SS\$_ACCVIO

An argument was not accessible to the caller.

SS\$_BADPARAM

The options flags were invalid.

SS\$_EXASTLM

The process AST limit (ASTLM) was exceeded.

SS\$_ILLEFC

The event flag number was invalid.

SS\$_INSFARGS

A required argument was missing.

SS\$_INSFMEM

There was insufficient system dynamic memory for the operation.

SS\$_WRONGSTATE

The default transaction was being changed at the time of the call.

\$SET_DEFAULT_TRANSW

Set Default Transaction and Wait — Sets or clears the default transaction of the calling process. \$SET_DEFAULT_TRANSW always waits for the request to complete before returning to the caller. Other than this, it is identical to \$SET_DEFAULT_TRANS.

Format

```
SYSS$SET_DEFAULT_TRANSW  
    [efn] , [flags] , iosb [, [astadr] , [astprm] , [new_tid] , [old_tid]]
```

C Prototype

```
int sys$set_default_transw
```

```
(unsigned int efn, unsigned int flags, struct _iosb *iosb, ...);
```

\$SET_DEVICE

Set Device Characteristics — Modifies the characteristics of a device or the paths used to access that device. For synchronous completion, use the Set Device Characteristics and Wait (\$SET_DEVICEW) service. The \$SET_DEVICEW service is identical to the \$SET_DEVICE service, except that \$SET_DEVICEW returns to the caller only after the requested action has taken effect. For additional information about system service completion, see the Synchronize (\$SYNCH) service.

Format

```
SYSS$SET_DEVICE  
    [efn] [,chan] [,devnam] ,itmlst [,iosb] [,astadr] [,astprm] [,nullarg]
```

C Prototype

```
int sys$set_device  
    (unsigned int efn, unsigned short int chan, void *devnam, void *itmlst,  
     struct _iosb *iosb, void (*astadr)(__unknown_params), int astprm,  
     struct_generic_64 *nullarg);
```

Arguments

efn

OpenVMS usage: ef_number
type: longword (unsigned)
access: read only
mechanism: by value

Number of the event flag to be set when \$SET_DEVICE returns the requested information. The *efn* argument is a longword containing this number; however, \$SET_DEVICE uses only the low-order byte.

Upon request initiation, \$SET_DEVICE clears the specified event flag (or event flag 0 if *efn* was not specified). Then, when \$SET_DEVICE returns the requested information, it sets the specified event flag (or event flag 0).

chan

OpenVMS usage: channel
type: word (unsigned)
access: read only
mechanism: by value

Number of the I/O channel assigned to the device about which information is desired. The *chan* argument is a word containing this number.

To identify a device to \$SET_DEVICE, you can specify either the *chan* or *devnam* parameters, but you should not specify both. If you specify both arguments, the *chan* argument is used.

If you specify neither *chan* nor *devnam*, \$SET_DEVICE uses a default value of 0 for *chan*.

devnam

OpenVMS usage: device_name
 type: character-coded text string
 access: read only
 mechanism: by 32- or 64-bit descriptor-fixed-length string descriptor

The name of the device about which \$SET_DEVICE is to modify the characteristics or path settings. The *devnam* argument is the address of a character string descriptor pointing to this name string.

The device name string can be either a physical device name or a logical name. If the first character in the string is an underscore (_), the string is considered a physical device name; otherwise, the string is considered a logical name and logical name translation is performed until either a physical device name is found or the system default number of translations has been performed.

If the device name string contains a colon (:), the colon and the characters that follow it are ignored.

To identify a device to \$SET_DEVICE, you can specify either the *chan* or *devnam* argument, but you should not specify both. If both arguments are specified, the *chan* argument is used.

If you specify neither *chan* nor *devnam*, \$SET_DEVICE uses a default value of 0 for *chan*.

itmlst

OpenVMS usage: item_list_3
 type: longword (unsigned)
 access: read only
 mechanism: by reference

Item list specifying which information about the device is to be returned. The *itmlst* argument is the address of a list of item descriptors, each of which describes an item of information. The list of item descriptors is terminated by a longword of 0.

Currently, \$SET_DEVICE allows only one valid item list entry.

The following diagram depicts the format of a single item descriptor:

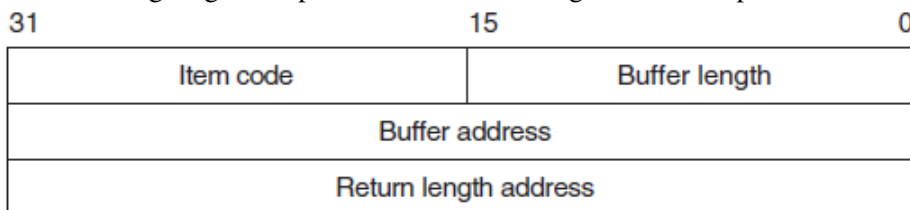

ZK-5186A-GE

See the *itmlst* argument in the \$GETDVI system service description for information on the meaning of these fields in the item list.

iosb

OpenVMS usage: io_status_block

type: quadword (unsigned)
access: write only
mechanism: by reference

I/O status block that is to receive the final completion status. The *iosb* argument is the address of the quadword I/O status block. See *iosb* in the \$GETDVI system service description for more information.

astadr

OpenVMS usage: ast_procedure
type: procedure value
access: call without stack unwinding
mechanism: by reference

AST service routine to be executed when \$SET_DEVICE completes. The *astadr* argument is the address of this routine.

If you specify *astadr*, the AST routine executes at the same access mode as the caller of the \$SET_DEVICE service.

astprm

OpenVMS usage: user_arg
type: longword (unsigned)
access: read only
mechanism: by value

AST parameter to be passed to the AST service routine specified by the *astadr* argument. The *astprm* argument is the longword parameter.

nullarg

OpenVMS usage: null_arg
type: quadword (unsigned)
access: read only
mechanism: by reference

Placeholding argument reserved to OpenVMS and should be zero.

Item Codes

SDV\$_MP_SWITCH_PATH

Forces an immediate I/O path switch for the specified device. The active path will be switched from the current I/O path to the path name specified in the buffer for this item code. Note that issuing \$SET_DEVICE with SDV\$_MP_SWITCH_PATH will initiate the process of switching the path. A delay may occur between when the service completes and when the path switch is complete. A synchronous version of this service, \$SET_DEVICEW, is available that will wait until the path switch attempt is complete before returning to the caller.

The path name specified in this and the following item codes must be fully specified. It may be in either uppercase or lowercase, however the entire name must be specified.

The Return Length field in this and the following item codes should set to zero.

The SDVDEF macro contains these item codes.

SDV\$_MP_DISABLE_PATH

Disables the path specified in the buffer for this item code so that it will no longer be considered as a switch candidate. Note that this does not apply to the current path, which cannot be disabled. The reasons one might want to disable a path include the following:

- You know a specific path is broken or that a failover to that path will cause some members of the cluster to lose access.
- To prevent automatic switching to a selected path while it is being serviced.

SDV\$_MP_ENABLE_PATH

Reenables the path name specified in the buffer for this item code as a switch candidate.

Description

The Set Device service modifies the characteristics of devices or I/O paths that have been established to those devices. For Multipath, the service allows the user to switch the current I/O path to a different available path and to enable and disable paths from being used for I/O.

Required Access or Privileges

None

Required Quota

None

Related Services

\$ASSIGN, \$DASSGN, \$DEVICE_SCAN, \$DEVICE_PATH_SCAN, \$GETDVI, \$GETDVIW

Condition Values Returned

SS\$_NORMAL

The service completed successfully.

SS\$_ACCVIO

The device name string descriptor, device name string, or *itmlst* argument cannot be read; or the buffer or return length longword cannot be written.

SS\$_BADPARAM

The item list contains an invalid item code, or the buffer length field in an item descriptor specified insufficient space for the return length information.

SS\$_DEVOFFLINE

The specified path is not available.

SS\$_EXQUOTA

Quota for pool has been exceeded.

SS\$_IVCHAN

You specified an invalid channel number, that is, a channel number larger than the number of channels.

SS\$_IVDEVNAM

The device name string contains invalid characters, or neither the *devnam* nor *chan* argument was specified.

SS\$_MPDEVBUSY

The specified path for this device is temporarily unavailable. This condition is quite rare; if this status is returned, the operation should be retried immediately, because the cause of the unavailability is very short-lived.

SS\$_MPDEVUSERDISABLE

The user has disabled the specified path for this device.

SS\$_NOOPER

Caller does not have OPER privileges.

SS\$_NOPRIV

The specified channel is not assigned or was assigned from a more privileged access mode.

SS\$_NOSUCHDEV

The specified device does not exist on the host system.

SS\$_NOSUCHPATH

The specified pathname does not exist on the host system.

SS\$_PATHAMBIG

The specified pathname is ambiguous for this device.

\$SET_DEVICEW

Set Device Characteristics and Wait — Modifies the characteristics of a device or the paths used to access that device. The `$SET_DEVICEW` completes synchronously; that is, it returns to the caller only after the requested action has taken effect.

Format

`SYS$SET_DEVICEW`

```
[efn] [,chan] [,devnam] ,itmlst [,iosb] [,astadr] [,astprm] [,nullarg]
```

C Prototype

```
int sys$set_devicew  
    (unsigned int efn, unsigned short int chan, void *devnam, void *itmlst,  
     struct _iosb *iosb, void (*astadr)(__unknown_params), int astprm,  
     struct_generic_64 *nullarg);
```

\$SET_IMPLICIT_AFFINITY (Alpha and Integrity servers)

Modify Process Implicit Affinity — On Alpha and Integrity server systems, controls or retrieves the activation state for the implicit affinity system capability of a specific kernel thread or of the global process default. This service accepts 64-bit addresses.

Format

```
SYSS$SET_IMPLICIT_AFFINITY  
    [pidadr] [,prcnam] [,state] [,cpu_id] [,prev_mask]
```

C Prototype

```
int sys$set_implicit_affinity  
    (unsigned int *pidadr, void *prcnam, struct _generic_64 *state,  
     int cpu_id, struct _generic_64 *prev_mask);
```

Arguments

pidadr

OpenVMS usage: process_id
type: longword (unsigned)
access: read only
mechanism: by 32- or 64-bit reference

Process identification (PID) of a kernel thread whose implicit affinity is to be modified or returned. The *pidadr* argument is the 32- or 64-bit address of a longword that contains the PID.

Process selection is made through a combination of the *pidadr* and *prcnam* arguments. If neither are specified or if both have a zero value, the service operations are made to the user capability mask of the current kernel thread of the current calling process. The *pidadr* argument takes precedence over the *prcnam* argument where both are supplied in the service call.

If the bit constant `CAP$M_IMPLICIT_DEFAULT_ONLY` is specified in the *state* argument, then the implicit affinity state portion of the default capability mask is modified or returned instead.

prcnam

OpenVMS usage: process_name

type: character-coded text string
 access: read only
 mechanism: by 32- or 64-bit descriptor–fixed-length string descriptor

Process name of the process whose implicit affinity capability state is to be modified or returned. The *prcnam* argument is the 32- or 64-bit address of a character string descriptor pointing to the process name string. A process can be identified with a 1- to 15-character string. The service operations are made to the user capability mask of the initial thread of the specified process.

If *pidadr* and *prcnam* are both specified, then *pidadr* is modified or returned and *prcnam* is ignored. If neither argument is specified, then the context of the current kernel thread of the calling process is modified or returned.

state

OpenVMS usage: mask_quadword
 type: quadword (unsigned)
 access: read only
 mechanism: by 32- or 64-bit reference

State options that can be selected for the affected thread's implicit affinity. The *state* argument is a pointer to a quadword bit vector wherein a bit corresponds to a requested state for the implicit affinity feature. Only the bits specified below are used; the remainder of the quadword bits are reserved.

Each option (bit) has a symbolic name, defined in the \$CAPDEF macro. The *state* argument is constructed by performing a logical OR operation using the symbolic names of each desired option.

The following table describes the symbolic name of each option.

Symbolic Name	Description
CAP\$M_IMPLICIT_DEFAULT_ONLY	Indicates the specified operations are to be performed on the global cell instead of on a specific kernel thread. This bit supersedes any individual kernel thread specified in <i>pidadr</i> or <i>prcnam</i> . Specifying this bit constant applies the implicit affinity operations to all newly created processes.
CAP\$M_IMPLICIT_AFFINITY_SET	Indicates that the implicit affinity capability bit is to be set for the specified kernel thread. This is mutually exclusive with CAP\$M_IMPLICIT_AFFINITY_CLEAR.
CAP\$M_IMPLICIT_AFFINITY_CLEAR	Indicates that the implicit affinity capability bit is to be cleared for the specified kernel thread. This is mutually exclusive with CAP\$M_IMPLICIT_AFFINITY_SET.

cpu_id

OpenVMS usage: longword
 type: longword (unsigned)
 access: read only

mechanism: by value

Identifier of the CPU requested as the first CPU on which this kernel thread is to execute. The *cpu_id* is a longword containing this number, which is in the supported range of individual CPUs from 0 to `SYI$_MAX_CPUS - 1`.

If no explicit CPU is needed, specifying a value of `-1` in this argument indicates the system is to select the initial association based on system dynamics and load balancing.

Note that, regardless of what explicit CPU is supplied to this argument, it will be taken only as a suggestion. This service will attempt to make the requested association, but it will be superseded by another CPU if the system dynamics are adversely affected by the operation.

prev_mask

OpenVMS usage: mask_quadword
type: quadword (unsigned)
access: write only
mechanism: by 32- or 64-bit reference

Previous implicit affinity state mask for the specified kernel thread before execution of this call to `$SET_IMPLICIT_AFFINITY`. The *prev_mask* argument is the 32- or 64-bit address of a quadword into which `$SET_IMPLICIT_AFFINITY` writes a bit mask specifying the implicit affinity state.

The current state of the kernel thread's current implicit affinity feature can be determined by testing the returned mask with the symbolic bit definitions described for the *state* argument. These bit definitions are found in the `$CAPDEF` macro.

Description

The Modify Process Implicit Affinity system service modifies or returns the implicit affinity state for the specified kernel thread or from the system default process creation cell.

Setting a kernel thread's implicit affinity function indicates to the system that it is to schedule the process in ways that will maximize the cache and TB performance in the current symmetric multiprocessing (SMP) configuration. This might tend to bias the process towards specific CPUs more than the standard scheduling algorithm would normally have allowed.

Required Access or Privileges

The caller must have the `ALTPRI` privilege to call `SYI$SET_IMPLICIT_AFFINITY` to modify its own implicit affinity capability bit. To modify another process' capability mask, the caller must have:

`ALTPRI`—To modify any process with a matching UIC
`ALTPRI` and `GROUP`—To modify any process in the same UIC group
`ALTPRI` and `WORLD`—To modify any process

To call `SYI$SET_IMPLICIT_AFFINITY` simply to retrieve the state of a specific process or global bit, the caller need only have the following privileges:

`None`—To retrieve the state of itself or any process with a matching UIC
`GROUP`—To retrieve the state of any process in the same UIC group
`WORLD`—To retrieve the state of any process

Related Services

\$CPU_CAPABILITIES, \$PROCESS_CAPABILITIES, \$PROCESS_AFFINITY

Condition Values Returned

SS\$_NORMAL

The service completed successfully.

SS\$_BADPARAM

One or more arguments has an invalid value.

SS\$_ACCVIO

The service cannot access the locations specified by one or more arguments.

SS\$_NOSUCHTHREAD

The specified kernel thread does not exist.

SS\$_NONEXPR

The specified process does not exist, or an invalid process identification was specified.

SS\$_IVLOGNAM

The process name string has a length of 0 or more than 15 characters.

SS\$_NOPRIV

Insufficient privilege for attempted operation.

SS\$_CPUCAP

No CPU can run the specified process with new capabilities.

SS\$_INSFARG

Fewer than the required number of arguments were specified or no operation was specified.

\$SET_PROCESS_PROPERTIESW (Alpha and Integrity servers)

Sets Simple Value — On Alpha and Integrity server systems, sets a simple value associated with a process.

Format

```
SYS$SET_PROCESS_PROPERTIESW  
  mbz1 ,pidadr ,prcnam ,property ,value ,prev_value  
  [,bufsiz ,bufcnt ,flags]
```

C Prototype

```
int sys$set_process_propertiesw
(mbz1, unsigned int *pidadr, unsigned int *prcnam,
 unsigned int property, unsigned __int64 value,
 unsigned __int64 *prev_value,...);
```

Arguments

mbz1

Reserved for future OpenVMS use. Must be specified as 0.

pidadr

OpenVMS usage: process_id
type: longword (unsigned)
access: modify
mechanism: by reference

Process identification (PID) of the process whose system service logging characteristics are to be modified. The *pidadr* argument is the address of the PID.

Supported only for use with PPROP\$C_SS_LOG_ENABLE, PPROP\$C_SS_LOG_DISABLE, and PPROP\$C_SS_LOG_UNLOAD. Otherwise, must be specified as 0.

prcnam

OpenVMS usage: process_name
type: character-coded text string
access: read only
mechanism: by descriptor--fixed-length string descriptor

Process name of the process whose priority is to be changed. The *prcnam* argument is the address of a character string descriptor pointing to the process name. The process name can be 1 - 15 characters long.

You can use the *prcnam* argument only on behalf of processes in the same UIC group as the calling process. To affect system service logging for processes in other groups, you must specify the *pidadr* argument.

Supported only for use with PPROP\$C_SS_LOG_ENABLE, PPROP\$C_SS_LOG_DISABLE, and PPROP\$C_SS_LOG_UNLOAD. Otherwise, must be specified as 0.

property

OpenVMS usage: integer
type: longword (unsigned)
access: read only
mechanism: by value

A constant that selects which property to set.

Valid values for property are defined by the \$PPROPDEF macro as follows:

Property Code	Description
PPROP\$C_CASE_LOOKUP_TEMP	<p>The type of case lookup to use. This value is set for the life of the currently active image. This value reverts to the permanent case setting on image rundown. In the absence of an explicit case lookup specification in a user-provided NAML, RMS uses this value to determine the case setting for the current file operation. Valid values are PPROP\$K_CASE_BLIND and PPROP\$K_CASE_SENSITIVE. For additional information, see the <i>VSI OpenVMS Guide to OpenVMS File Applications</i>.</p>
PPROP\$C_CASE_LOOKUP_PERM	<p>The type of case lookup to use. This value is set for the life of the process or until the case is set again on rundown. Setting this value affects only future activated images for this process. To change the case setting for the current active image, you must modify the PPROP\$C_CASE_LOOKUP_TEMP setting.</p> <p>Valid values are PPROP\$K_CASE_BLIND and PPROP\$K_CASE_SENSITIVE.</p> <p>For additional information, see the <i>VSI OpenVMS Guide to OpenVMS File Applications</i>.</p>
PPROP\$C_SEARCH_SYMLINK_TEMP	<p>Processes the active search mode. The value reverts to the permanent setting on image rundown. Valid values are PPROP\$K_SEARCH_SYMLINK_NONE, PPROP\$K_SEARCH_SYMLINK_ALL, and PPROP\$K_SEARCH_SYMLINK_NOELLIPS.</p>
PPROP\$C_SEARCH_SYMLINK_PERM	<p>Processes the permanent search mode. This value is set for the life of the process. Changing this setting only changes the behavior of subsequently activated images. Valid values are PPROP\$K_SEARCH_SYMLINK_NONE, PPROP\$K_SEARCH_SYMLINK_ALL, and PPROP\$K_SEARCH_SYMLINK_NOELLIPS.</p>
PPROP\$C_DEADLOCK_WAIT	<p>The per-process deadlock wait time (in 100-ns units). A value of zero resets and disables the per-process deadlock wait time and fallback to the systemwide deadlock wait time that comes from the system parameter DEADLOCK_WAIT. Valid values are in the range of 100000 (=10ms) and 10000000 (=1 s). If the value is too small, the per-process deadlock wait is set to 10 ms; if the value is too large, it is set to 1 s.</p>
PPROP\$C_HOME_RAD	<p>The Resource Affinity Domain (RAD) to which the process is assigned. Newly mapped memory in the process will come from the home RAD of the process. Currently mapped memory will not move into the new home RAD unless \$PURGWS is issued. Valid values are integers between 0 and the maximum RAD on the</p>

Property Code	Description
	system. Valid home RADs must also contain either memory or CPUs.
PPROP\$C_KERNEL_THREAD_LIMIT	Sets the process specific limit of the number of kernel threads that can be created. By default, this is controlled systemwide through the SYSGEN parameter MULTITHREAD. A value between 0 (use default) and the current setting of the MULTITHREAD parameter can be used.
PPROP\$C_MEDDLE	Reserved for OpenVMS use.
PPROP\$C_MEDDLE_ENABLE	Reserved for OpenVMS use.
PPROP\$C_PARSE_STYLE_TEMP	The type of command parsing to use. This value is set only for the life of the image. The value reverts to the permanent style on image rundown. Valid values are PARSE_STYLE\$C_TRADITIONAL and PARSE_STYLE\$C_EXTENDED.
PPROP\$C_PARSE_STYLE_PERM	The type of command parsing to use. This value is set for the life of the process unless the style is set again. Valid values are PARSE_STYLE\$C_TRADITIONAL and PARSE_STYLE\$C_EXTENDED.
PPROP\$C_SS_LOG_DISABLE	<p>Stop logging system service requests for the current or specified process. If logging was previously disabled, the value returned in <i>prev_value</i> is 0. If logging was previously enabled, the value returned is 1.</p> <p>For more information, see the <i>VSI OpenVMS System Analysis Tools Manual</i>.</p>
PPROP\$C_SS_LOG_ENABLE	<p>Allocate log buffers and enable logging of system service requests for the current or specified process. If logging was previously disabled, the value returned in <i>prev_value</i> is 0. If logging was previously enabled, the value returned is 1.</p> <p>For more information, see the <i>VSI OpenVMS System Analysis Tools Manual</i>.</p>
PPROP\$C_SS_LOG_UNLOAD	<p>Stop logging system service requests for the current or specified process and close the log file so that it can be analyzed. If logging was previously disabled, the value returned in <i>prev_value</i> is 0. If logging was previously enabled, the value returned is 1.</p> <p>For more information, see the <i>VSI OpenVMS System Analysis Tools Manual</i>.</p>
PPROP\$C_TOKEN	Controls the token size used by DCL. When the bit is clear (the default), traditional tokens are used, and each command token can hold up to 255 characters. When the bit is set, extended tokens are used; each command token can be up to 4000 characters.

Property Code	Description
PPROP\$C_UNITS	Controls the process units. When the bit is clear (the default), all size-related numbers are displayed in blocks. When the bit is set, size-related numbers are converted to bytes.

value

OpenVMS usage: integer
type: quadword (unsigned)
access: read
mechanism: by value

A quadword value to which to set the property.

prev_value

OpenVMS usage: access_mode
type: quadword (unsigned) address of a quadword value
access: write
mechanism: by reference

The address of a quadword that will receive the previous value of the property.

bufsize

OpenVMS usage: longword_unsigned
type: longword (unsigned)
access: read only
mechanism: by value

The requested system service log buffer size in bytes. Supported only for use with PPROP\$C_SS_LOG_ENABLE. If omitted, it defaults to 65,024 bytes. The maximum value is 65,024 bytes. The minimum value is 4096 bytes.

bufcnt

OpenVMS usage: longword_unsigned
type: longword (unsigned)
access: read only
mechanism: by value

The requested number of system service log buffers. Supported only for use with PPROP\$C_SS_LOG_ENABLE. If omitted, it defaults to 2. The maximum number of buffers is 6.

flags

OpenVMS usage: mask_longword
type: longword (unsigned)
access: read only

mechanism: by value

Flag mask specifying the enable logging request. The *flags* argument is a longword bit vector in which each bit corresponds to a flag. The \$LOGTYPDEF macro and the LOGTYPDEF.H file define a symbolic name for each flag.

The \$LOGTYPDEF macro defines the following symbolic names for the fault characteristic codes:

Symbol	Description
LOGTYP\$M_ARGS	Log system service arguments.
LOGTYP\$M_FILE	Write log information to a file.

If you specify the *flags* argument as 0, the service defaults to logging to a file and logging arguments.

If you specify LOGTYP\$M_ARGS but lack privilege, service arguments are not logged.

Description

The \$SET_PROCESS_PROPERTIESW system service sets a simple value associated with a process.

Generally, this service is used for changing process properties that have a maximum of a single quadword. You can change only one property at a time per call to this service.

Required Access or Privileges

To affect system service logging for another process, the calling process might need one of the following privileges:

- GROUP privilege to affect a process in the same group, unless the target process has the same UIC as the calling process.
- WORLD privilege to affect any process in the system.

To request logging the arguments passed to a system service, a process needs SETPRV, CMKRNL, or CMEXEC privilege.

Required Quota

When system service logging is enabled, the log buffers are charged against the process's paging file quota (PGFLQUOTA).

Related Services

\$GETJPI

Condition Values Returned

SS\$_NORMAL

The service completed successfully.

SS\$_ACCVIO

Access violation.

SS\$_WRONGSTATE

An attempt was made to modify system service logging characteristics of a process when logging is disabled systemwide.

SS\$_NONEXPR

The specified process does not exist, or an invalid process identification was specified.

SS\$_NOPRIV

The process does not have the privilege to affect the other process.

SS\$_IVLOGNAM

The process name string has a length of 0 or has more than 15 characters.

\$SET_RESOURCE_DOMAIN

Set Resource Domain — Controls the association between a calling process and resource domains.

Format

```
SYS$SET_RESOURCE_DOMAIN
    func ,rsdm_id ,domain_number , [nullarg] , [access] , [acmode]
```

C Prototype

```
int sys$set_resource_domain
    (unsigned int func, unsigned int *rsdm_id, unsigned int domain_number,
     unsigned int nullarg, unsigned int access, unsigned int acmode);
```

Arguments

func

OpenVMS usage: function_code
type: longword (unsigned)
access: read only
mechanism: by value

Function code specifying the action that \$SET_RESOURCE_DOMAIN is to perform. The *func* argument is a longword containing this function code. See the Function Codes section for a description of \$SET_RESOURCE_DOMAIN function codes.

rsdm_id

OpenVMS usage: longword
type: longword (unsigned)
access: write only to join, read only to leave
mechanism: by reference

Resource domain identification. The *r sdm_id* argument is the address of a longword specifying the association of the calling process with the resource domain.

The RSDM\$_JOIN_DOMAIN function returns a resource domain identification. The RSDM\$_LEAVE function requires the *r sdm_id* argument as input to specify which resource domain association the process is leaving.

The resource domain identification can be used as input to the \$ENQ and \$ENQW system services.

domain_number

OpenVMS usage: longword
 type: longword (unsigned)
 access: read only
 mechanism: by value

Domain number that identifies the resource domain. The *domain_number* argument is a longword value containing the resource domain number.

The *domain_number* argument is required for the RSDM\$_JOIN_DOMAIN function but ignored for the RSDM\$_LEAVE function.

nullarg

OpenVMS usage: null_arg
 type: longword (unsigned)
 access: read only
 mechanism: by value

Placeholder reserved to OpenVMS. You must specify 0.

access

OpenVMS usage: mask_longword
 type: longword (unsigned)
 access: read only
 mechanism: by value

Types of access desired when using the lock management services within the resource domain. The *access* argument is a longword bit mask specifying the access types required; these can include read, write, and lock.

The following table lists the symbols that the \$RSDMDEF macro defines, their descriptions, and the lock management system services that might require each type of access.

Symbol	Access Description	System Service
RSDM\$_READ	Read lock value blocks	\$DEQ, \$ENQ, \$ENQW, \$GETLKI, \$GETLKIW
RSDM\$_WRITE	Write lock value blocks	\$DEQ, \$ENQ, \$ENQW,
RSDM\$_LOCK	Take locks	\$ENQ, \$ENQW

The service grants the desired access, provided your process has the necessary access rights to the resource domain. If you do not specify the *access* argument or if you specify 0, `$SET_RESOURCE_DOMAIN` attempts to access the domain in the following order:

1. Read, write, lock
2. Read, lock
3. Write, lock
4. Lock

The access attempt terminates with the first success.

The *access* argument defaults to 0. It is ignored for the `RSDM$_LEAVE` function.

acmode

OpenVMS usage: `access_mode`
 type: longword (unsigned)
 access: read only
 mechanism: by value

Access mode requested for the association to the resource domain. The most privileged access mode granted is the access mode of the caller. Locks cannot be taken from access modes less privileged than the access mode of the association.

The *acmode* argument is a longword containing the access mode. The `$PSLDEF` macro defines the following symbols for the access modes.

Symbolic Name	Access Mode	Privilege Rank
<code>PSL\$C_KERNEL</code>	Kernel	High
<code>PSL\$C_EXEC</code>	Executive	–
<code>PSL\$C_SUPER</code>	Supervisor	–
<code>PSL\$C_USER</code>	User	Low

The *acmode* argument is optional for the `RSDM$_JOIN_DOMAIN` function. If you do not specify the *acmode* argument, the access mode is set to the access mode of the calling process. The *acmode* argument is ignored for the `RSDM$_LEAVE` function.

Function Codes

RSDM\$_JOIN_DOMAIN

A process has the option of forming multiple associations with one or more resource domains. Each association can have different access rights to the resource domain, such as to read lock value blocks or to write lock value blocks. This request sets up a new association with a resource domain.

`$SET_RESOURCE_DOMAIN` verifies the desired access against the security profile of the resource domain. If the desired access is allowed, a new association to the resource domain is created, and a resource domain identification for the association is returned.

This function code returns the following condition values:

SS\$_NORMAL
SS\$_BADPARAM
SS\$_EXQUOTA
SS\$_INSFMEM
SS\$_NOOBSRV
SS\$_NOPRIV

RSDM\$_LEAVE

This operation requests that a process end an association with a resource domain. A process must leave a resource domain association in the same mode as, or in a more privileged mode than, the mode in which it joined the resource domain.

Before a process can end its association with a resource domain, it must release all locks taken using that association.

This function code returns the following condition values:

SS\$_NORMAL
SS\$_BADPARAM
SS\$_IVMODE
SS\$_RSDM_ACTIVE
SS\$_RSDMNOTFOU

Description

The Set Resource Domain system service enables a process to use the lock management system services \$DEQ, \$ENQ, \$ENQW, \$GETLKI, and \$GETLKIW.

The lock management services enable processes with the appropriate access rights to take and release locks on resource names and to perform other functions related to lock management. Applications use resource names to represent resources to which they want to synchronize access. A resource domain is a namespace for resource names. A process must join a resource domain to take and release locks and to read and write value blocks associated with resources in that resource domain.

When a process requests to join a resource domain, \$SET_RESOURCE_DOMAIN performs an access check. After \$SET_RESOURCE_DOMAIN verifies the desired access to the resource domain, the service creates an association between the resource domain and the calling process. The association is represented by a resource domain identification. A process can request different types of access to the same resource domain; the type of access is a characteristic of the association with the resource domain. Each time a process joins a resource domain, a new association is created. Processes use their resource domain identifications when using \$ENQ or \$ENQW to request a new lock.

The service can grant the following three types of access to resource domains:

- The right to read lock value blocks
- The right to write lock value blocks
- The right to take and release locks

Required Access or Privileges

None

Required Quota

\$SET_RESOURCE_DOMAIN uses system dynamic memory, which uses BYTLM quota, for the creation of the resource domain data structures.

Related Services

\$DEQ, \$ENQ, \$ENQW, \$GETLKI, \$GETLKIW

Condition Values Returned

SS\$_NORMAL

The service completed successfully.

SS\$_BADPARAM

The *func*, the *domain_number*, or the *r sdm_id* argument was specified incorrectly.

SS\$_EXQUOTA

The caller has insufficient BYTLM quota.

SS\$_INSFMEM

There is insufficient memory to join the resource domain.

SS\$_IVMODE

An attempt was made to leave an association created by a more privileged access mode.

SS\$_NOOBSRV

The audit server process, which maintains the security profile for resource domains, is not running. The process access rights to the domain cannot be determined, so access is denied.

SS\$_NOPRIV

Access to the resource domain was denied.

SS\$_RSDM_ACTIVE

Unable to leave the resource domain because there are locks still associated with this resource domain.

SS\$_RSDMNOTFOU

The resource domain was not found.

\$SET_RETURN_VALUE (Alpha and Integrity servers)

Sets the return value of — On Alpha and Integrity server systems, sets the return values or condition codes in the Mechanism Array, independent of the architecture.

Format

`SYSS$SET_RETURN_VALUE mechanism_arg, return_type, return_value`

C Prototype

```
int sys$set_return_value
    (void *mechanism_arg, unsigned int *return_type, void *return_value);
```

Arguments

mechanism_arg

OpenVMS usage: mechanism vector address
type: quadword (unsigned)
access: read only
mechanism: by value

The address of the location of the mechanism vector. If the *mechanism_arg* argument is 0, the mechanism vector for the currently active signal is used.

If the address of the *return_type* argument is 0, the *return_value* argument is fetched by value and is treated as return-type PSIG\$K_FR_U32. This combination of arguments can be used to set a condition code, such as SS\$_ACCVIO, as a return value.

return_type

OpenVMS usage: integer
type: longword (unsigned)
access: read only
mechanism: by reference

The address of the location of a longword that contains one of the function return signature codes.

If the address of the *return_type* argument is 0, the *return_value* argument is fetched by value and is treated as return-type PSIG\$K_FR_U32. This combination of arguments can be used to set a condition code, such as SS\$_ACCVIO, as a return value.

return_value

OpenVMS usage: buffer
type: scalar
access: read only
mechanism: by reference

The address of the location that contains a value of the appropriate type. The referenced value is read as a longword, quadword, or octaword, depending on the *return_type*.

If the address of the *return_type* argument is 0, the *return_value* argument is fetched by value and is treated as return-type PSIG\$K_FR_U32. This combination of arguments can be used to set a condition code, such as SS\$_ACCVIO, as a return value.

Description

The Set Return Value service allows the caller to specify return values and condition codes in the Mechanism Array, independent of the architecture.

Required Access or Privileges

None

Required Quota

None

Related Services

None

Condition Values Returned

status

Success or failure. The given return value is placed in the appropriate fields of the specified mechanism vector, according to the return type.

SS\$_NORMAL

The service completed successfully.

SS\$_NOSIGNAL

No signal is currently active for an exception condition.

\$SET_SECURITY

Set Security Characteristics — Modifies the security characteristics of a protected object.

Format

```
SYS$SET_SECURITY
    [clsnam] , [objnam] , [objhan] , [flags] , [itmlst] , [contxt] , [acmode]
```

C Prototype

```
int sys$set_security
    (void *clsnam, void *objnam, unsigned int *objhan, unsigned int flags,
     void *itmlst, unsigned int *contxt, unsigned int *acmode);
```

Arguments

clsnam

OpenVMS usage: char_string
 type: character-coded text string
 access: read only
 mechanism: by descriptor

Name of the object class. The *clsnam* argument is the address of a descriptor pointing to a string that contains the name of the object class.

The following is a list of the protected object class names:

CAPABILITY
 COMMON_EVENT_CLUSTER
 DEVICE
 FILE
 GLXGRP_GLOBAL_SECTION
 GLXSYS_GLOBAL_SECTION
 GROUP_GLOBAL_SECTION
 ICC_ASSOCIATION
 LOGICAL_NAME_TABLE
 QUEUE
 RESOURCE_DOMAIN
 SECURITY_CLASS
 SYSTEM_GLOBAL_SECTION
 VOLUME

objnam

OpenVMS usage: char_string
 type: character-coded text string
 access: read only
 mechanism: by descriptor

Name of the protected object whose associated security profile is going to be retrieved. The *objnam* argument is the address of a descriptor pointing to a string containing the name of the protected object.

The format of an object name is class specific. The following table lists object names and describes their formats.

Object Class	Object Name Format
CAPABILITY	A character string. Currently, the only capability object is VECTOR.
COMMON_EVENT_CLUSTER	Name of the event flag cluster, as defined in the Associate Common Event Flag Cluster (\$ASCEFC) system service.
DEVICE	Standard device specification, described in the <i>VSI OpenVMS User's Manual</i> .
FILE	Standard file specification, described in the <i>VSI OpenVMS User's Manual</i> .
GROUP_GLOBAL_SECTION	Section name, as defined in the Create and Map Section (\$CRMPSC) system service.

Object Class	Object Name Format
ICC_ASSOCIATION	ICC security object name <i>node::association_name</i> . The special node name, ICC\$:, refers to entries in the clusterwide registry. For registry entries, the Access Access Type does not apply.
LOGICAL_NAME_TABLE	Table name, as defined in the Create Logical Name Table (\$CRELNT) system service.
QUEUE	Standard queue name, as described in the Send to Job Controller (\$SNDJBC) system service.
RESOURCE_DOMAIN	An identifier or octal string enclosed in brackets.
SECURITY_CLASS	Any class name shown in the Object Class column of this table, or a class name followed by a period (.) and the template name. Use the DCL command SHOW SECURITY to display possible template names.
SYSTEM_GLOBAL_SECTION	Section name, as defined in the Create and Map Section (\$CRMPSC) system service.
VOLUME	Volume name or name of the device on which the volume is mounted.

objhan

OpenVMS usage: object_handle
type: longword (unsigned)
access: read only
mechanism: by reference

Data structure identifying the object to address. The *objhan* argument is an address of a longword containing the object handle. You can use the *objhan* argument as an alternative to the *objnam* argument; for example, a channel number clearly specifies the file open on the channel and can serve as an object handle. The following table shows the format of the object classes.

Object Class	Object Handle Format
COMMON_EVENT_CLUSTER	Event flag number
DEVICE	Channel number
FILE	Channel number
RESOURCE_DOMAIN	Resource domain identifier
VOLUME	Channel number

flags

OpenVMS usage: flags
type: mask_longword
access: read only
mechanism: by value

Mask specifying processing options. The *flags* argument is a longword bit vector wherein a bit, when set, specifies the corresponding option. The *flags* argument requires the *context* argument. The following table describes each flag.

Symbolic Name	Description
OSS\$M_LOCAL	Do not update the master profile for the specified object. This flag allows you to call \$SET_SECURITY several times to modify a local copy of a profile; once the modifications are satisfactory, you can clear the OSS\$M_LOCAL flag, set the OSS\$M_RELCTX flag, and have \$SET_SECURITY update the master profile. The flag applies only to calls made with the <i>context</i> argument.
OSS\$M_RELCTX	Release the context structure at the completion of this request.

The \$OSSDEF macro defines symbolic names for the flag bits. You construct the *flags* argument by specifying the symbolic names of each desired option.

itmlst

OpenVMS usage: item_list_3
 type: longword (unsigned)
 access: read only
 mechanism: by reference

Item list specifying which information about the process or processes is to be modified. The *itmlst* argument is the address of a list of item descriptors, each of which describes an item of information. The list of item descriptors is terminated by a longword of 0.

With the item list, the user modifies the protected object's characteristics. The user defines which security characteristics to modify. If this argument is not present, only the *flags* argument is processed. Without the *itmlst* argument, you can *only* manipulate the security profile locks or release *context* resources.

The following data structure depicts the format of a single item descriptor.

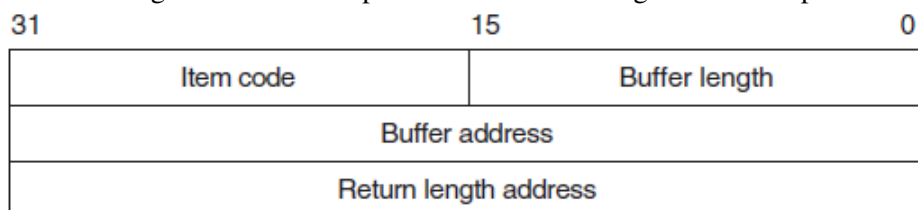

ZK-5186A-GE

The following table defines the item descriptor fields.

Descriptor Field	Definition
Buffer length	A word containing an integer specifying the length (in bytes) of the buffer from which \$SET_SECURITY is to read the information. The length of the buffer needed depends upon the item code specified in the item code field of the item descriptor. If the value of buffer length is too small, \$SET_SECURITY truncates the data.
Item code	A word containing a symbolic code specifying the item of information that \$SET_SECURITY is to modify. The \$OSSDEF macro defines these codes. A description of each item code is given in the Item Codes section.
Buffer address	A longword containing the address of the buffer from which \$SET_SECURITY is to read the information.

Descriptor Field	Definition
Return length address	Not used.

contxt

OpenVMS usage: context
 type: longword (unsigned)
 access: modify
 mechanism: by reference

Value used to maintain protected object processing context when dealing with a single protected object across multiple \$GET_SECURITY/\$SET_SECURITY calls. Whenever the context value is nonzero, the class name, object name, or object handle arguments are disregarded. An input value of 0 indicates that a new context should be established.

Because an active context block consumes process memory, be sure to release the context block by setting the RELCTX flag when the profile processing is complete. \$SET_SECURITY sets the context argument to 0 once the context is released.

acmode

OpenVMS usage: access_mode
 type: longword (unsigned)
 access: read only
 mechanism: by reference

Access mode to be used in the object protection check. The *acmode* argument is the address of a longword containing the access mode. The *acmode* argument defaults to kernel mode; however, the system compares *acmode* with the caller's access mode and uses the least privileged mode. The access modes are defined in the system macro \$PSLDEF library.

VSI recommends that this argument be omitted (passed as zero).

Item Codes

The following table provides a summary of item codes that are valid as an item descriptor in the *itmlst* argument. The table lists the \$SET_SECURITY item codes and gives a corresponding description. Complete descriptions of each item code are provided after the table.

Item Code	Description
OSS\$_ACL_ADD_ENTRY	Adds an access control entry (ACE).
OSS\$_ACL_DELETE	Deletes all unprotected ACEs in an ACL.
OSS\$_ACL_DELETE_ALL	Deletes the ACL, including protected ACEs.
OSS\$_ACL_DELETE_ENTRY	Deletes an ACE.
OSS\$_ACL_FIND_ENTRY	Locates an ACE.
OSS\$_ACL_FIND_NEXT	Positions the next ACE.
OSS\$_ACL_FIND_TYPE	Locates an ACE of the specified type.
OSS\$_ACL_MODIFY_ENTRY	Replaces an ACE at the current position.

Item Code	Description
OSS\$_ACL_POSITION_BOTTOM	Sets a marker that points to the end of the ACL.
OSS\$_ACL_POSITION_TOP	Sets a marker that points to the beginning of the ACL.
OSS\$_OWNER	Sets the UIC or general identifier of the object's owner.
OSS\$_PROTECTION	Sets the protection code of the object.

OSS\$_ACL_ADD_ENTRY

When you specify OSS\$_ACL_ADD_ENTRY, \$SET_SECURITY adds an access control entry (ACE) pointed to by the buffer address so that it is in front of the current ACE in the access control list (ACL). See OSS\$_ACL_POSITION for more information on explicit access control list positioning.

OSS\$_ACL_DELETE

When you specify OSS\$_ACL_DELETE, \$SET_SECURITY deletes all unprotected ACEs in an ACL.

OSS\$_ACL_DELETE_ALL

When you specify OSS\$_ACL_DELETE_ALL, \$SET_SECURITY deletes an entire ACL, including protected ACEs.

OSS\$_ACL_DELETE_ENTRY

When you specify OSS\$_ACL_DELETE_ENTRY, \$SET_SECURITY deletes an ACE pointed to by the buffer address or, if the buffer address is specified as 0, the ACE at the current position.

OSS\$_ACL_FIND_ENTRY

When you specify OSS\$_ACL_FIND_ENTRY, \$SET_SECURITY locates an ACE pointed to by the buffer address. OSS\$_ACL_FIND_ENTRY sets the position within the ACL for succeeding ACL operations; for example, for a deletion or modification of the ACE. If the buffer address is 0, it returns SS\$_ACCVIO.

OSS\$_ACL_FIND_NEXT

When you specify OSS\$_ACL_FIND_NEXT, \$SET_SECURITY advances the current position to the next ACE in the ACL.

OSS\$_ACL_FIND_TYPE

When you specify OSS\$_ACL_FIND_TYPE, \$SET_SECURITY returns an ACE of a particular type if there is one in the buffer pointed to by the buffer address. OSS\$_ACL_FIND_TYPE sets the position within the ACL for succeeding ACL operations. If the buffer address is 0, it returns SS\$_ACCVIO.

OSS\$_ACL_MODIFY_ENTRY

When you specify OSS\$_ACL_MODIFY_ENTRY, \$SET_SECURITY replaces an ACE at the current position with the ACE pointed to by the buffer address.

OSS\$_ACL_POSITION_BOTTOM

When you specify OSS\$_ACL_POSITION_BOTTOM, \$SET_SECURITY sets the ACL position to point to the bottom of the ACL.

OSS\$_ACL_POSITION_TOP

When you specify `OSS$_ACL_POSITION_TOP`, `$SET_SECURITY` sets the ACL position to point to the top of the ACL.

OSS\$_OWNER

When you specify `OSS$_OWNER`, `$SET_SECURITY` sets the owner UIC of the selected object to the value in the buffer. The buffer size must be 4 bytes.

OSS\$_PROTECTION

When you specify `OSS$_PROTECTION`, `$SET_SECURITY` sets the selected object's protection code to the value in the buffer. The buffer size must be 2 bytes.

Description

The Set Security service modifies the security characteristics of a protected object. Security characteristics include such information as the protection code, the owner, and the access control list (ACL).

The security management services, `$SET_SECURITY` and `$GET_SECURITY`, maintain a single master copy of a profile for every protected object in an OpenVMS Cluster system. They also ensure that only one process at a time can modify an object's security profile.

When you call `$SET_SECURITY`, the service performs the following steps:

1. It selects the specified protected object.
2. It fetches a local copy of the object's security profile, unless the service is operating on an existing context.
3. It modifies the local profile.
4. It updates the master copy of the profile if the local flag is clear and there was no error.
5. It deletes the local copy of the profile and returns if `RELCTX` is specified or if no context is specified.

There are different ways of identifying which protected object `$SET_SECURITY` should process:

- Whenever the *context* argument has a nonzero value, `$SET_SECURITY` uses the context to select the object and ignores the class name, object name, and object handle.
- With some types of objects, such as a file or a device, it is possible to select an object on the basis of its *objhan* and *clsnam* values.
- When the *clsnam* and *objnam* arguments are provided, `$SET_SECURITY` uses an object's class name and object name to select the object.

The context for a security management operation can be established through either `$GET_SECURITY` or `$SET_SECURITY`. Whenever the context is set by one service, the other service can use it provided the necessary locks are being held. A caller to `$GET_SECURITY` needs to set the write lock flag (`OSS$M_WLOCK`) to inspect a profile value, maintain the lock on the object's profile, and then modify some value through a call to `$SET_SECURITY`.

There are many situations in which the *context* argument is essential. By establishing a context for an ACL operation, for example, a caller can retain an ACL position across calls to `$GET_SECURITY`

so that a set of ACEs can be read and modified sequentially. A security context is released by a call to `$SET_SECURITY` or `$GET_SECURITY` that sets the `OSS$M_RELCTX` flag. Once the context is deleted, the user-supplied context longword is reset to 0.

Required Access or Privileges

Control access to the object is required.

Required Quota

None

Related Services

`$GET_SECURITY`

Condition Values Returned

SS\$_NORMAL

The service completed successfully

SS\$_ACCVIO

The parameter cannot be read and the buffer cannot be written.

SS\$_BADPARAM

You specified an invalid object, attribute code, or item size.

SS\$_INSFARG

The `clsnam` and `objnam` arguments are not specified, the `clsnam` and `objhan` arguments are not specified, or the `context` argument is not specified.

SS\$_INVBUFLN

The buffer size for one of the item codes was invalid.

SS\$_INVCLSITM

The item code that you specified is not supported for the class.

SS\$_INVFILFOROP

An invalid file name was specified; the file name contained either a node or wildcard specification.

SS\$_MMATORB

The attempted update cannot be performed. The object profile was changed by another process.

SS\$_NOCLASS

The named object class does not exist.

SS\$_OBJLOCKED

The selected object is currently write locked.

\$SET_SYSTEM_EVENT (Alpha and Integrity servers)

Set System Event — On Alpha and Integrity server systems, establishes a request for notification when an OpenVMS system event occurs.

Format

```
SY$SET_SYSTEM_EVENT event ,astadr ,astprm ,acmode ,flags ,handle
```

C Prototype

```
int sys$set_system_event
(unsigned int event, void (*astadr)(__unknown_params), int astprm,
 unsigned int acmode, unsigned int flags, struct _generic_64 * handle);
```

Arguments

event

OpenVMS usage: event_code
 type: longword (unsigned)
 access: read only
 mechanism: by value

Event code indicating the type of system event for which an AST is to be delivered. The *event* argument is a value indicating which type of event is of interest.

Each event type has a symbolic name. The \$SYSEVTDEF macro defines the following symbolic names:

Symbolic Name	Description
SYSEVT\$C_ADD_MEMBER	One or more OpenVMS instances have joined the OpenVMS Galaxy sharing community.
SYSEVT\$C_DEL_MEMBER	One or more OpenVMS instances have left the OpenVMS Galaxy sharing community.
SYSEVT\$C_ADD_ACTIVE_CPU	One or more processors have become active within this OpenVMS instance.
SYSEVT\$C_DEL_ACTIVE_CPU	One or more processors have become inactive within this OpenVMS instance.
SYSEVT\$C_ADD_CONFIG_CPU	One or more CPUs have been added to the set of available CPUs for this OpenVMS instance.
SYSEVT\$C_DEL_CONFIG_CPU	One or more processors have been removed from this OpenVMS instance.
SYSEVT\$C_TDF_CHANGE	The system's time differential factor has changed.
SYSEVT\$C_CPU_DEALLOCATE	One or more processors have been deallocated from this OpenVMS instance.

astadr

OpenVMS usage: ast_procedure
type: procedure value
access: call without stack unwinding
mechanism: by 32-bit or 64-bit reference

Notification AST routine to receive control after a change in OpenVMS system configuration occurs.

astprm

OpenVMS usage: user_arg
type: quadword
access: read only
mechanism: by value

The quadword AST parameter to be passed to the AST routine.

acmode

OpenVMS usage: access_mode
type: longword (unsigned)
access: read only
mechanism: by value

Access mode at which the system event AST is to execute. The *acmode* argument is a longword containing the access mode.

Each access mode has a symbolic name. The \$PSLDEF macro defines the following symbols for the four access modes.

Symbolic Name	Description
PSL\$C_KERNEL	Kernel
PSL\$C_EXEC	Executive
PSL\$C_SUPER	Supervisor
PSL\$C_USER	User

The value of the access mode is maximized with the access mode of the caller.

flags

Defined in SYSEVTDEF.

SYSEVT\$M_REPEAT_NOTIFY When this flag is set, event notification is repeated.

handle

OpenVMS usage: handle
type: quadword (unsigned)
access: read/write
mechanism: by reference

The virtual address of a naturally aligned quadword for the event handle.

Description

The Set System Event service establishes a request for notification when a system event occurs. It may create a new system event notification object, add an event to a new or existing object, and enable notification on a new or existing object.

If the *handle* specified is zero, a new system notification request object is created, and a handle for the new object is returned.

If the *event* specified is non-zero, that event is added to the set of events which trigger notification on the notification object.

The service will verify that the input parameters specify a valid request and enable the object for notification. Notification is accomplished by AST delivery. After the AST has been delivered, if the SYSEVT\$M_REPEAT_NOTIFY flag is not set, notification must again be enabled on the object before another notification (AST delivery) can occur.

Errors are returned in the following cases:

- If quotas are exceeded, an error is returned. It is important to note that this routine returns an error and will not retry an attempt to get quota if quota is exhausted on the first attempt.
- See the Condition Values Returned section for types of errors that can be returned.
- If the *astadr* argument is omitted, and a new notification object is being created, SS\$_BADPARAM is returned.
- If the *event* argument is incorrectly specified, SS\$_BADPARAM is returned.
- If the access mode parameter is more privileged than the mode of the caller, the mode of the caller is used.
- If specified, the *handle* argument must be writeable from the mode of the caller. SS\$_ACCVIO is returned if this is not the case.

Required Access or Privileges

None

Required Quota

ASTLM

Related Services

\$CLEAR_SYSTEM_EVENT

Condition Values Returned

SS\$_NORMAL

The service completed successfully.

SS\$_ACCVIO

The service cannot access the locations specified by one or more arguments.

SS\$_BADPARAM

One of more arguments has an invalid value.

SS\$_EXASTLM

The process exceeded its quota for outstanding ASTs.

SS\$_INSFMEM

The system dynamic memory is insufficient to complete the service.

\$SET_UNWIND_TABLE (Integrity servers Only)

Set Unwind Table Routine — Registers or extends unwind table (UT) information.

Format

```
SYS$SET_UNWIND_TABLE
    code_base_va, code_size, ut_base_va, ut_size, gp_value,
    unwind_info_base, name
```

C Prototype

```
int SYS$SET_UNWIND_TABLE
    (unsigned __int64 code_base_va, unsigned __int64 code_size,
    unsigned __int64 ut_base_va, unsigned __int64 ut_size,
    unsigned __int64 gp_value, unsigned __int64 unwind_info_base,
    void *name);
```

Arguments

code_base_va

OpenVMS usage: address
type: quadword (unsigned)
access: read only
mechanism: by value

With *code_size*, defines the potential code range. *code_base_va* is required for both creation and extension calls. *code_base_va* is the process virtual address of the start of the code region. *code_size* is the size of the code region in bytes. An error is returned if this overlaps any existing range.

code_size

OpenVMS usage: address
type: quadword (unsigned)
access: read only

mechanism: by value

With *code_base_va*, defines the potential code range. *code_base_va* is required for both creation and extension calls. *code_base_va* is the process virtual address of the start of the code region. *code_size* is the size of the code region in bytes. An error is returned if this overlaps any existing range.

ut_base_va

OpenVMS usage: address
type: quadword (unsigned)
access: read only
mechanism: by value

With *ut_size*, describes the unwind table (UT). *ut_base_va* is the process virtual address of the UT and must be quadword aligned. *ut_size* is the size of the UT in bytes and must be a multiple of the size (24 bytes: 3 quadwords) of an unwind table entry (UTE). The UTEs must describe nonoverlapping code subregions within the overall code region.

ut_size

OpenVMS usage: address
type: quadword (unsigned)
access: read only
mechanism: by value

With *ut_base_va*, describes the unwind table (UT). *ut_base_va* is the process virtual address of the UT and must be quadword aligned. *ut_size* is the size of the UT in bytes and must be a multiple of the size (24 bytes: 3 quadwords) of an unwind table entry (UTE). The UTEs must describe nonoverlapping code sub regions within the overall code region.

gp_value

OpenVMS usage: address
type: quadword (unsigned)
access: read only
mechanism: by value

Ignored on extension calls, required on create calls. The Global Data Pointer (GP) value for the routines described by these unwind tables.

unwind_info_base

OpenVMS usage: address
type: quadword (unsigned)
access: read only
mechanism: by value

Ignored on extension calls; required on create calls. The *unwind_info_base* plus a particular UTE UIB offset must add up to the process virtual address of that UIB. Typically for static code (activated

images from disk), this specifies the process virtual base address of the segment containing the UIBs. However, dynamically generated code, for example, can pass a zero for the `unwind_info_base` and have the full process virtual addresses of the UIBs in their UTEs.

name

OpenVMS usage: pseudo-image-name
type: character-code-text-string
access: read only
mechanism: by descriptor-fixed-length string descriptor

Passed by descriptor (ignored on extension calls). May be used for traceback. Need not be unique. Should be less than 255 characters (will be truncated, otherwise).

Description

This interface can be used to register or extend unwind information. It is expected, for example, that applications that dynamically create code will also need to dynamically create unwind tables (UTs) and unwind information blocks (UIBs) for that code. This interface registers such information with the operating system.

The image activator also uses this interface to register unwind information for shareable and main images. Note that the code region, though fully specified in terms of its potential size, need not be full of actual code at its initial registration. The unwind table, however, must describe all the code that could execute within that region and that needs unwind information, at any given time. Note also that the unwind table entries (UTEs) within a registered unwind table must remain sorted (ascending order) at any given time.

To create a new registration, specify a new (not registered) code range. On a creation, all parameters (except `name`) must be specified.

To extend an existing registration, specify an existing (registered) `code_base_va`. On extension, only the identifying `code_base_va` and new UT range need be specified, that is, the other parameters may be zeros. An extension call can only alter that registration's `ut_base_va` and `ut_size`.

The creator caller's mode defines the mode from which the registration may be extended or removed.

Failure status is returned on creation if the input code range overlaps an already existing range.

Required Access or Privileges

Unwind table information that describes code in process space can be registered from any mode.

Unwind table information that describes code in system space can be registered only from kernel mode or executive mode.

Required Quota

None

Related Services

SYSS\$CLEAR_UNWIND_TABLE, SYSS\$GET_UNWIND_ENTRY_INFO. Also see LIB\$GET_UIB_INFO in *VSI OpenVMS Calling Standard*.

Condition Values Returned

SS\$_NORMAL

Routine completed successfully.

SS\$_BADPARAM

Missing or illegal parameter.

SS\$_VA_IN_USE

Overlap detected.

SS\$_ACCVIO

Name descriptor cannot be read.

\$SHOW_INTRUSION

Show Intrusion Information — Searches for and returns information about records in the intrusion database matching the caller's specifications.

Format

```
SYSSHOW_INTRUSION
    user_criteria , intruder , intruder_len , breakin_block , [flags] , [context]
```

C Prototype

```
int sys$show_intrusion
    (void *user_criteria, void *intruder, unsigned short int *intruder_len,
     void *breakin_block, unsigned int flags, unsigned int *context);
```

Arguments

user_criteria

OpenVMS usage: char_string or item_list_3
type: character-coded text string or longword (unsigned)
access: read only
mechanism: by descriptor—fixed length string descriptor

If the CIA\$_ITEMLIST flag is FALSE:

The *user_criteria* argument is the description of intruder or suspect. The *user_criteria* argument is the address of a character-string descriptor pointing to a buffer containing the user criteria to match an intrusion record's user specification in the intrusion database.

The *user_criteria* argument is a character string of between 1 and 1058 bytes containing characters to match the user specification on records in the intrusion database.

A user specification is any combination of the suspect's or intruder's source node name, source user name, source DECnet for OpenVMS address, local failed user name, local terminal, or the string UNKNOWN. The user specification for an intrusion record is based on the input to the \$SCAN_INTRUSION service and the settings of the LGI system parameter. For more information, see the *VSI OpenVMS Guide to System Security*.

Wildcards are allowed for the *user_criteria* argument. For more information about using wildcards to scan the intrusion database, see the Description section.

If the CIA\$M_ITEMLIST flag is TRUE:

The *user_criteria* argument is now the address of an 32-bit item list. If the item list is used, one item, the CIA\$_USER_CRITERIAL item, must be present in the item list.

The following table lists the valid item descriptions for the *user_criteria* argument:

Item	Description
CIA\$_OUTPUT_LIST	Address of an 8192-byte buffer into which the service writes the associated node information for the returned intrusion record.
CIA\$_SCSNODE_LIST	Address of a list of 8-character null-padded SCS nodenames for which the caller wants to see intrusion information about.
CIA\$_USER_CRITERIAL	Address of a buffer, 1-1058 bytes long, containing the intruder or suspect.

If a CIA\$_SCSNODE_LIST item is provided, an intrusion record will only be returned if it originated on one of the nodes specified. If a CIA\$_SCSNODE_LIST item is not provided, records from all nodes will be candidates for display. Multiple CIA\$_SCSNODE_LIST items are permitted in the item list.

If a CIA\$_OUTPUT_LIST item is provided, the item is filled with node-count records on return. The returned intrusion record will have a breakin block with a valid attempt-count field. The node-count records will have the name and attempt-count for each node represented.

intruder

OpenVMS usage: char_string
 type: character-coded text string
 access: write only
 mechanism: by descriptor—fixed length string descriptor

User specification of the matched intruder or suspect record in the intrusion database. The *intruder* argument is the address of a character-string descriptor pointing to a buffer to receive the user specification of the matched record in the intrusion database.

The *intruder* argument is a 1058-byte string that will receive the user specification of a record in the intrusion database that matches the specifications in the *user_criteria* and *flags* arguments.

intruder_len

OpenVMS usage: string length
 type: longword (unsigned)
 access: write only
 mechanism: by reference

Length of returned string in the intrusion buffer. The *intruder_len* argument is the address of a longword to receive the length of the returned intrusion buffer.

The possible range of the *intruder_len* argument is 0 to 1058 bytes. If the longword specified by the argument contains a 0 after the call to the service, either the service did not find a record that matched the user criteria in the intrusion database, or there are no more matching items in the intrusion database.

breakin_block

OpenVMS usage: record
 type: block of 2 longwords (unsigned) and 1 quadword (unsigned)
 access: write only
 mechanism: by reference

Block to receive various information in the intrusion database about a record matching the user criteria. The *breakin_block* argument is the address of a structure with the following format.

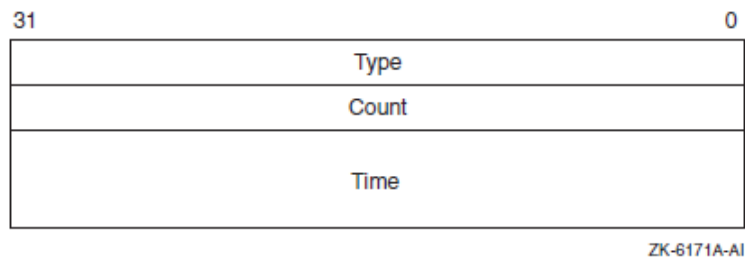

The following table defines the break-in block fields.

Field	Description
Type	Unsigned longword containing two pieces of information: the types of the matched record and the status of the suspect—SUSPECT or INTRUDER. The possible values for the record type are TERM_USER, TERMINAL, USERNAME, and NETWORK. The possible values for the status are SUSPECT or INTRUDER. These constants are defined in \$CIADEF in STARLET. The implication is that each type will have two bits set: one bit represents the status, and the other bit represents the record type.
Count	Unsigned longword containing the number of login failures or break-in attempts made by the specified intruder or suspect.
Time	Quadword time format indicating the time when the record will expire.

flags

OpenVMS usage: mask_longword
 type: longword (unsigned)
 access: read only
 mechanism: by value

Type of records in the intrusion database about which information is to be returned. The *flags* argument is a longword bit mask wherein each bit corresponds to an option.

Each option has a symbolic name. The \$CIADEF macro defines the following valid names.

Symbolic Name	Description
CIA\$M_ALL	All records will be shown. If the <i>flags</i> argument is omitted, this value is assumed.
CIA\$M_INTRUDERS	Only intruder records matching the criteria specified by the <i>user_criteria</i> argument will be returned. The value of the flag field in the break-in block will always be 1.
CIA\$M_ITEMLIST	If FALSE, the <i>user_criteria</i> argument is a character string. If TRUE, this argument is a 32-bit item list.
CIA\$M_SUSPECTS	Only suspect records matching the criteria specified by the <i>user_criteria</i> argument will be returned. The value of the flag field in the break-in block will always be 0.

Each of these options is mutually exclusive.

context

OpenVMS usage: context
 type: longword (unsigned)
 access: write only
 mechanism: by reference

Context information to keep between related calls to the \$SHOW_INTRUSION service. The *context* argument is the address of a longword that receives a context from the service.

The initial value contained in the unsigned longword pointed to by the *context* argument must be 0. The contents of the unsigned longword must not be changed after the service has set its value. If the contents of the *context* argument are changed between calls to the service, SS\$_BADCONTEXT will be returned.

Contexts become invalid after one-half hour of non-use. This means that if you call the \$SHOW_INTRUSION service with a wildcard in the *user_criteria* argument and do not call the service to get the next matching record within one-half hour, the context becomes invalid. If the context has become invalid, you must restart your search of the intrusion database from the beginning by resetting the context to 0.

Description

The Show Intrusion service returns information about records in the intrusion database that match the criteria you specify.

You can retrieve information about multiple records in the intrusion database by specifying wildcards for the *user_criteria* argument. For example, specifying an asterisk (*) for the *user_criteria* argument and CIA\$M_ALL_RECORDS for the *flags* argument will return information about all records in the database. Specifying TTA4* for the *user_criteria* argument and CIA\$M_SUSPECTS_ONLY for the *flags* argument will return information about all suspects who have had failures on terminal TTA4.

If you specify a wildcard string for the *user_criteria* argument, you must also include a *context* argument. Because the service can only return information about one intrusion record at

a time, you must call the service repeatedly to retrieve information about more than one record. The service will return `SS$_NOMOREITEMS` when information about all of the matching records has been returned. No intrusion information is returned from the call that returns `SS$_NOMOREITEMS`.

Required Access or Privileges

`SECURITY` privilege is required.

Required Quota

None

Related Services

`$DELETE_INTRUSION`, `$SCAN_INTRUSION`

Condition Values Returned

`SS$_NORMAL`

The service completed successfully.

`SS$_ACCVIO`

The *user_criteria* or *context* argument cannot be read, or the *intruder*, *intruder_len*, *breakin_block*, or *context* argument cannot be written.

`SS$_BADBUFLEN`

The length of one of the specified arguments is out of range.

`SS$_BADCONTEXT`

The *context* argument did not contain a 0 on the first call to the service. The *context* argument's value changed between consecutive calls to the service.

`SS$_BADPARAM`

An invalid value was specified in the *flags* argument, or mutually exclusive options were specified in the *flags* argument.

`SS$_NOMOREITEMS`

All items matching the specified criteria have been returned.

`SS$_NOSECURITY`

The caller does not have `SECURITY` privilege.

This service can also return any of the following messages passed from the security server:

`SECSRV$_NOSUCHINTRUDER`

No records matching the specified criteria were found in the intrusion database.

SECSRV\$_SERVERNOTACTIVE

The security server is not currently active. Try the request again later.

\$SIGNAL_ARRAY_64

Signal Array — Returns the address of a 64-bit signal array. A 32-bit signal array and a mechanism array are passed to a condition handler when it is called. \$SIGNAL_ARRAY_64 provides the address of the 64-bit signal array, which might be required for programs that use 64-bit address space. This service accepts 64-bit addresses.

Format

```
SYS$SIGNAL_ARRAY_64 mcharg, sigarg_64
```

C Prototype

```
int sys$signal_array_64  
    (unsigned __int64 mcharg, unsigned __int64 sigarg_64);
```

Arguments

mcharg

OpenVMS usage: mechanism array
type: vector quadword (unsigned)
access: read only
mechanism: by 32- or 64-bit reference, array reference

The mechanism array. The *mcharg* argument is the 32- or 64-bit address of this array, which was passed to the condition handler. \$SIGNAL_ARRAY_64 uses this structure to determine the 64-bit signal array address.

sigarg_64

OpenVMS usage: 64-bit signal array
type: vector quadword (unsigned)
access: write only
mechanism: by 32- or 64-bit reference, array reference

The 32- or 64-bit address of the 64-bit signal array is returned in this argument.

Description

\$SIGNAL_ARRAY_64 provides the address of the 64-bit version of the signal array for condition handlers that need it. It is normally needed only by applications that use 64-bit address space and want to handle errors involving addresses in that region.

For example, if an access violation occurs on a 64-bit address, the 32-bit signal array passed to the handler will contain only the low 32 bits of the effective address, because each entry is a longword. The

64-bit signal array, which can be obtained using this service, contains quadword entries, so the 64-bit address can be fully expressed.

Required Access or Privileges

None

Required Quota

None

Related Services

\$PUTMSG, which accepts either a 32-bit or 64-bit signal array as an argument.

Condition Values Returned

SS\$_NORMAL

The service completed successfully.

SS\$_ACCVIO

The *sigarg_64* argument cannot be written.

SS\$_BADPARAM

The *mcharg* argument is not a mechanism array in the expected format.

\$SENDERR

Send Message to Error Logger — Writes a user-specified message to the system error log file, preceding it with the date and time.

Format

SYS\$SENDERR msgbuf

C Prototype

```
int sys$senderr (void *msgbuf);
```

Argument

msgbuf

OpenVMS usage:	char_string
type:	character-coded text string
access:	read only
mechanism:	by descriptor–fixed-length string descriptor

Message to be written to the error log file. The *msgbuf* argument is the address of a character string descriptor pointing to the message text.

Description

The Send Message to Error Logger service writes a user-specified message to the system error log file, preceding it with the date and time. The `$$SENDERR` service requires system dynamic memory.

Required Access or Privileges

To send a message to the error log file, the calling process must have `BUGCHK` privilege.

Required Quota

None

Related Services

`$ALLOC`, `$ASSIGN`, `$BRKTHRU`, `$BRKTHRUW`, `$CANCEL`, `$CREMBX`, `$DALLOC`, `$DASSGN`, `$DELMBX`, `$DEVICE_SCAN`, `$DISMOU`, `$GETDVI`, `$GETDVIW`, `$GETMSG`, `$GETQUI`, `$GETQUIW`, `$INIT_VOL`, `$MOUNT`, `$PUTMSG`, `$QIO`, `$QIOW`, `$$SNDJBC`, `$$SNDJBCW`, `$$SNDOPR`

Condition Values Returned

`SS$_NORMAL`

The service completed successfully.

`SS$_ACCVIO`

The message buffer or buffer descriptor cannot be read by the caller.

`SS$_INSFMEM`

The system dynamic memory is insufficient for completing the service.

`SS$_NOPRIV`

The process does not have the required `BUGCHK` privilege.

`$$SNDJBC`

Send to Job Controller — Creates, stops, and manages queues and the batch and print jobs in those queues. The `$$SNDJBC` service completes asynchronously; to synchronize the completion of most operations, use the Send to Job Controller and Wait (`$$SNDJBCW`) service.

Format

```
SYS$$SNDJBC  
    [efn] ,func [,nullarg] [,itmlst] [,iosb] [,astadr] [,astprm]
```

C Prototype

```
int sys$sndjbc
(unsigned int efn, unsigned short int func, unsigned int nullarg,
 void *itmlst, struct _iosb *iosb, void (*astadr)(__unknown_params),
 int astprm);
```

Arguments

efn

OpenVMS usage: `ef_number`
type: longword (unsigned)
access: read only
mechanism: by value

Number of the event flag to be set when \$SNDJBC completes. The *efn* argument is a longword containing this number; however, \$SNDJBC uses only the low-order byte.

When you queue the request, \$SNDJBC clears the specified event flag (or event flag 0 if *efn* was not specified). Then, when the operation completes, \$SNDJBC sets the specified event flag (or event flag 0).

func

OpenVMS usage: `function_code`
type: word (unsigned)
access: read only
mechanism: by value

Function code specifying the function that \$SNDJBC is to perform. The *func* argument is a word containing this function code. The \$SJCDEF macro defines the names of each function code.

You can specify only one function code in a single call to \$SNDJBC. Most function codes require or allow for additional information to be passed in the call. You pass this information by using the *itmlst* argument, which specifies a list of one or more item descriptors. Each item descriptor in turn specifies an item code, which modifies, restricts, or otherwise affects the action designated by the function code.

nullarg

OpenVMS usage: `null_arg`
type: longword (unsigned)
access: read only
mechanism: by value

Placeholder argument reserved to OpenVMS.

itmlst

OpenVMS usage: `item_list_3`
type: longword (unsigned)
access: read only

mechanism: by reference

Item list supplying information to be used in performing the function specified by the *func* argument. The *itmlst* argument is the address of the item list. The item list consists of one or more item descriptors, each of which specifies an item code. The item list is terminated by an item code of 0 or by a longword of 0. The following diagram depicts the structure of a single item descriptor.

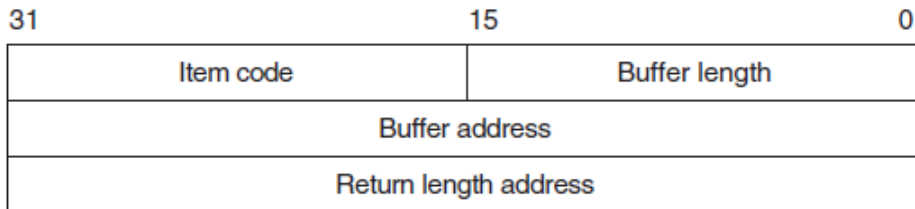

ZK-5186A-GE

The following table defines the item descriptor fields.

Descriptor Field	Definition
Buffer length	A word specifying the length of the buffer; the buffer either supplies information to be used by \$SNDJBC or receives information from \$SNDJBC. The required length of the buffer varies, depending on the item code specified, and is given in the description of each item code.
Item code	A word containing an item code, which identifies the nature of the information supplied for use by \$SNDJBC or received from \$SNDJBC. Each item code has a symbolic name. The \$SJCDEF macro defines these symbol names.
Buffer address	A longword containing the address of the buffer that specifies or receives the information.
Return length address	A longword containing the address of a word to receive the length (in bytes) of information returned by \$SNDJBC. If you specify this address as 0, no length is returned.

The item codes' symbolic names have the following format:

SJC\$_code

There are three types of item code:

- Boolean item code. Boolean item codes specify a true or false value; the form SJC\$_code specifies a true value; SJC\$_NO_code specifies a false value. The default value for the Boolean item codes is false. For all Boolean item codes, the buffer length, buffer address, and return length fields of the item descriptor must be 0.
- Input value item code. Input value item codes specify an input value to be used by \$SNDJBC. The buffer length and buffer address fields of the item descriptor must be nonzero; the return length field must be 0. Specific buffer length requirements are given in the description of each item code.
- Output value item code. Output value item codes specify a buffer for information returned by \$SNDJBC. The buffer length and buffer address fields of the item descriptor must be nonzero; the return length field can be 0 or nonzero. Specific buffer length requirements are given in the description of each item code.

Several item codes specify a queue name, form name, or characteristic name. For these item codes, the buffer must specify a string containing from 1 to 31 characters, exclusive of spaces, tabs, and null

characters, which are ignored. Allowable characters in the string are uppercase alphabetic characters, lowercase alphabetic characters (which are converted to uppercase), numeric characters, the dollar sign (\$), and the underscore (_).

iosb

OpenVMS usage: `io_status_block`
type: quadword (unsigned)
access: write only
mechanism: by reference

I/O status block into which \$SNDJBC writes the completion status after the requested operation has completed. The *iosb* argument is the address of the I/O status block.

At request initiation, \$SNDJBC sets the value of the quadword I/O status block to 0. When the requested operation completes, \$SNDJBC writes a condition value in the first longword of the I/O status block. It writes the value 0 into the second longword; this longword is unused and reserved for future use.

The condition values returned by \$SNDJBC in the I/O status block are usually condition values from the JBC facility. These condition values are defined by the \$JBCMSGDEF macro. In some cases, the condition value returned by \$SNDJBC can be an error return from a system service or an OpenVMS RMS service that is used in executing the request. For the `SJC$_SYNCHRONIZE_JOB` request, the condition value returned is the completion status of the requested job.

The condition values returned from the JBC facility are listed in the Condition Values Returned in the I/O Status Block section.

Though this argument is optional, VSI strongly recommends that you specify it, for the following reasons:

- If you are using an event flag to signal the completion of the service, you can test the I/O status block for a condition value to be sure that the event flag was not set by an event other than service completion.
- If you are using the \$SYNCH service to synchronize completion of the service, the I/O status block is a required argument for \$SYNCH.
- The condition value returned in R0 and the condition value returned in the I/O status block provide information about different aspects of the call to the \$SNDJBC service. The condition value returned in R0 gives you information about the success or failure of the service call itself; the condition value returned in the I/O status block gives you information about the success or failure of the service operation. Therefore, to accurately assess the success or failure of the call to \$SNDJBC, you must check the condition values returned in both R0 and the I/O status block.

astadr

OpenVMS usage: `ast_procedure`
type: procedure value
access: call without stack unwinding
mechanism: by reference

AST service routine to be executed when \$SNDJBC completes. The *astadr* argument is the address of this routine.

If specified, the AST routine executes at the same access mode as the caller of \$SNDJBC.

astprm

OpenVMS usage: user_arg
 type: longword (unsigned)
 access: read only
 mechanism: by value

AST parameter to be passed to the AST service routine specified by the *astadr* argument. The *astprm* argument is this longword parameter.

Function Codes

This section describes the various function codes that are applicable to the \$SNDJBC system service.

SJC\$_ABORT_JOB

This request aborts the execution of the current job from an output execution queue or the job you specified from a batch queue. By default, the job is deleted. However, for a restartable job, you can requeue it to the same queue or to another queue.

You must specify one of the following input value item codes:

SJC\$_ENTRY_NUMBER
 SJC\$_QUEUE

You must specify the following input value item code for batch jobs:

SJC\$_ENTRY_NUMBER

You can specify the following optional input value or Boolean item codes:

SJC\$_DESTINATION_QUEUE	—
SJC\$_HOLD	SJC\$_NO_HOLD
SJC\$_PRIORITY	—
SJC\$_REQUEUE	—

SJC\$_ADD_FILE

This request adds a file to the open job owned by the requesting process. You use this operation as part of a sequence of calls to the \$SNDJBC service to create a job with one or more files. The first call in the sequence specifies the SJC\$_CREATE_JOB operation to create an open job. Each subsequent SJC\$_ADD_FILE request associates an additional file with the job. Finally, you make an SJC\$_CLOSE_JOB request to complete the batch or print job specification. To create a job that contains only one file, you can make a single call to \$SNDJBC that specifies the SJC\$_ENTER_FILE function code.

You must specify one of the following input value item codes:

SJC\$_FILE_IDENTIFICATION
 SJC\$_FILE_SPECIFICATION

You can specify the following input value or Boolean item codes:

SJC\$_DELETE_FILE	SJC\$_NO_DELETE_FILE
SJC\$_DOUBLE_SPACE	SJC\$_NO_DOUBLE_SPACE
SJC\$_FILE_BURST	SJC\$_NO_FILE_BURST
SJC\$_FILE_COPIES	—
SJC\$_FILE_FLAG	SJC\$_NO_FILE_FLAG
SJC\$_FILE_SETUP_MODULES	SJC\$_NO_FILE_SETUP_MODULES
SJC\$_FILE_TRAILER	SJC\$_NO_FILE_TRAILER
SJC\$_FIRST_PAGE	SJC\$_NO_FIRST_PAGE
SJC\$_LAST_PAGE	SJC\$_NO_LAST_PAGE
SJC\$_PAGE_HEADER	SJC\$_NO_PAGE_HEADER
SJC\$_PAGINATE	SJC\$_NO_PAGINATE
SJC\$_PASSALL	SJC\$_NO_PASSALL

SJC\$_ALTER_JOB

This request alters the parameters of an existing job that is not currently executing.

You must specify the following input value item code:

SJC\$_ENTRY_NUMBER

You can specify the following input value or Boolean item codes:

SJC\$_AFTER_TIME	SJC\$_NO_AFTER_TIME
SJC\$_CHARACTERISTIC_NAME	SJC\$_NO_CHARACTERISTICS
SJC\$_CHARACTERISTIC_NUMBER	—
—	SJC\$_NO_CHECKPOINT_DATA
SJC\$_CLI	SJC\$_NO_CLI
SJC\$_CPU_LIMIT	SJC\$_NO_CPU_LIMIT
—	SJC\$_NO_DELETE_FILE
SJC\$_DESTINATION_QUEUE	—
SJC\$_DOUBLE_SPACE	SJC\$_NO_DOUBLE_SPACE
SJC\$_FILE_BURST	SJC\$_NO_FILE_BURST
SJC\$_FILE_COPIES	—
SJC\$_FILE_FLAG	SJC\$_NO_FILE_FLAG
SJC\$_FILE_SETUP_MODULES	SJC\$_NO_FILE_SETUP_MODULES
SJC\$_FILE_TRAILER	SJC\$_NO_FILE_TRAILER
SJC\$_FIRST_PAGE	SJC\$_NO_FIRST_PAGE
SJC\$_FORM_NAME	—
SJC\$_FORM_NUMBER	—
SJC\$_HOLD	SJC\$_NO_HOLD
SJC\$_JOB_COPIES	—

SJC\$_JOB_DEFAULT_RETAIN	—
SJC\$_JOB_ERROR_RETAIN	—
SJC\$_JOB_NAME	—
SJC\$_JOB_RETAIN	—
SJC\$_JOB_RETAIN_TIME	—
SJC\$_LAST_PAGE	SJC\$_NO_LAST_PAGE
SJC\$_LOG_DELETE	SJC\$_NO_LOG_DELETE
SJC\$_LOG_QUEUE	—
SJC\$_LOG_SPECIFICATION	SJC\$_NO_LOG_SPECIFICATION
SJC\$_LOG_SPOOL	SJC\$_NO_LOG_SPOOL
SJC\$_LOWERCASE	SJC\$_NO_LOWERCASE
SJC\$_NOTE	SJC\$_NO_NOTE
SJC\$_NOTIFY	SJC\$_NO_NOTIFY
SJC\$_OPERATOR_REQUEST	SJC\$_NO_OPERATOR_REQUEST
SJC\$_PAGE_HEADER	SJC\$_NO_PAGE_HEADER
SJC\$_PAGINATE	SJC\$_NO_PAGINATE
SJC\$_PARAMETER_1 through 8	SJC\$_NO_PARAMETERS
SJC\$_PASSALL	SJC\$_NO_PASSALL
SJC\$_PRIORITY	—
SJC\$_QUEUE	—
SJC\$_RAD	SJC\$_NO_RAD
SJC\$_RESTART	SJC\$_NO_RESTART
SJC\$_WSDEFAULT	SJC\$_NO_WSDEFAULT
SJC\$_WSEXTENT	SJC\$_NO_WSEXTENT
SJC\$_WSQUOTA	SJC\$_NO_WSQUOTA

If you specify the SJC\$_QUEUE item code, the \$SNDJBC service verifies that the selected job entry exists on the specified queue before modifying the job.

SJC\$_ALTER_QUEUE

This request alters the parameters of a queue. The execution of current jobs is unaffected.

You must specify the following input value item code:

SJC\$_QUEUE

You can specify the following input value or Boolean item codes:

SJC\$_BASE_PRIORITY	—
SJC\$_CHARACTERISTIC_NAME	SJC\$_NO_CHARACTERISTICS
SJC\$_CHARACTERISTIC_NUMBER	—
SJC\$_CLOSE_QUEUE	—
SJC\$_CPU_DEFAULT	SJC\$_NO_CPU_DEFAULT

SJC\$_CPU_LIMIT	SJC\$_NO_CPU_LIMIT
SJC\$_DEFAULT_FORM_NAME	—
SJC\$_DEFAULT_FORM_NUMBER	—
SJC\$_FILE_BURST	SJC\$_NO_FILE_BURST
SJC\$_FILE_BURST_ONE	—
SJC\$_FILE_FLAG	SJC\$_NO_FILE_FLAG
SJC\$_FILE_FLAG_ONE	—
SJC\$_FILE_TRAILER	SJC\$_NO_FILE_TRAILER
SJC\$_FILE_TRAILER_ONE	—
SJC\$_FORM_NAME	—
SJC\$_FORM_NUMBER	—
SJC\$_GENERIC_SELECTION	SJC\$_NO_GENERIC_SELECTION
SJC\$_JOB_BURST	SJC\$_NO_JOB_BURST
SJC\$_JOB_FLAG	SJC\$_NO_JOB_FLAG
SJC\$_JOB_LIMIT	—
SJC\$_JOB_RESET_MODULES	SJC\$_NO_JOB_RESET_MODULES
SJC\$_JOB_SIZE_MAXIMUM	SJC\$_NO_JOB_SIZE_MAXIMUM
SJC\$_JOB_SIZE_MINIMUM	SJC\$_NO_JOB_SIZE_MINIMUM
SJC\$_JOB_SIZE_SCHEDULING	SJC\$_NO_JOB_SIZE_SCHEDULING
SJC\$_JOB_TRAILER	SJC\$_NO_JOB_TRAILER
SJC\$_OPEN_QUEUE	—
SJC\$_OWNER_UIC	—
SJC\$_PAGINATE	SJC\$_NO_PAGINATE
SJC\$_PROTECTION	—
SJC\$_QUEUE_DESCRIPTION	SJC\$_NO_QUEUE_DESCRIPTION
SJC\$_RAD	SJC\$_NO_RAD
SJC\$_RECORD_BLOCKING	SJC\$_NO_RECORD_BLOCKING
SJC\$_RETAIN_ALL_JOBS	SJC\$_NO_RETAIN_JOBS
SJC\$_RETAIN_ERROR_JOBS	—
SJC\$_SWAP	SJC\$_NO_SWAP
SJC\$_WSDEFAULT	SJC\$_NO_WSDEFAULT
SJC\$_WSEXTENT	SJC\$_NO_WSEXTENT
SJC\$_WSQUOTA	SJC\$_NO_WSQUOTA

SJC\$_ASSIGN_QUEUE

This request assigns a logical queue to an execution queue. The SJC\$_QUEUE item code specifies the logical queue; the SJC\$_DESTINATION_QUEUE item code specifies the execution queue.

You must specify the following input value item codes:

SJC\$_DESTINATION_QUEUE

SJC\$_QUEUE

SJC\$_BATCH_CHECKPOINT

This request establishes a checkpoint in a batch job. No operation is performed if the requesting process is not a batch process.

You must specify the following input value item code:

SJC\$_CHECKPOINT_DATA

SJC\$_CLOSE_DELETE

This request deletes the open job owned by the requesting process. No item codes are allowed.

SJC\$_CLOSE_JOB

This request completes the specification of the open job owned by the requesting process and places the job in the queue specified in the SJC\$_CREATE_JOB request that opened the job. If the SJC\$_CLOSE_JOB request completes successfully, the job is no longer an open job; it becomes a normal batch or print job.

You can specify the following output value item code:

SJC\$_JOB_STATUS_OUTPUT

SJC\$_CREATE_JOB

This request creates an open job for the requesting process. If the process already owns an open job, that job is deleted.

An open job is a batch or print job that has not yet been completely specified. After you make the SJC\$_CREATE_JOB request to open the job, you can make subsequent calls to \$SNDJBC using the SJC\$_ADD_FILE function code to specify the files associated with the job. Finally, you can complete the job specification with an SJC\$_CLOSE_JOB request. If the SJC\$_CREATE_JOB operation completes successfully, the open job created is given an entry number; the job is not assigned to the queue specified in the SJC\$_CREATE_JOB operation until the SJC\$_CLOSE_JOB request completes successfully.

You must specify the following input value item code:

SJC\$_QUEUE

You can specify the following input value or Boolean item codes:

SJC\$_ACCOUNT_NAME	—
SJC\$_AFTER_TIME	SJC\$_NO_AFTER_TIME
SJC\$_CHARACTERISTIC_NAME	SJC\$_NO_CHARACTERISTICS
SJC\$_CHARACTERISTIC_NUMBER	—
SJC\$_CLI	SJC\$_NO_CLI
SJC\$_CPU_LIMIT	SJC\$_NO_CPU_LIMIT
SJC\$_FILE_BURST	SJC\$_NO_FILE_BURST
SJC\$_FILE_BURST_ONE	—

SJC\$_FILE_FLAG	SJC\$_NO_FILE_FLAG
SJC\$_FILE_FLAG_ONE	—
SJC\$_FILE_TRAILER	SJC\$_NO_FILE_TRAILER
SJC\$_FILE_TRAILER_ONE	—
SJC\$_FIRST_PAGE	SJC\$_NO_FIRST_PAGE
SJC\$_FORM_NAME	—
SJC\$_FORM_NUMBER	—
SJC\$_HOLD	SJC\$_NO_HOLD
SJC\$_JOB_COPIES	—
SJC\$_JOB_DEFAULT_RETAIN	—
SJC\$_JOB_ERROR_RETAIN	—
SJC\$_JOB_NAME	—
SJC\$_JOB_RETAIN	—
SJC\$_JOB_RETAIN_TIME	—
SJC\$_LAST_PAGE	SJC\$_NO_LAST_PAGE
SJC\$_LOG_DELETE	SJC\$_NO_LOG_DELETE
SJC\$_LOG_QUEUE	—
SJC\$_LOG_SPECIFICATION	SJC\$_NO_LOG_SPECIFICATION
SJC\$_LOG_SPOOL	SJC\$_NO_LOG_SPOOL
SJC\$_LOWERCASE	SJC\$_NO_LOWERCASE
SJC\$_NOTE	SJC\$_NO_NOTE
SJC\$_NOTIFY	SJC\$_NO_NOTIFY
SJC\$_OPERATOR_REQUEST	SJC\$_NO_OPERATOR_REQUEST
SJC\$_PARAMETER_1 through 8	SJC\$_NO_PARAMETERS
SJC\$_PRIORITY	—
SJC\$_RAD	SJC\$_NO_RAD
SJC\$_RESTART	SJC\$_NO_RESTART
SJC\$_UIC	—
SJC\$_USERNAME	—
SJC\$_WSDEFAULT	SJC\$_NO_WSDEFAULT
SJC\$_WSEXTENT	SJC\$_NO_WSEXTENT
SJC\$_WSQUOTA	SJC\$_NO_WSQUOTA

You can specify the following output value item code:

SJC\$_ENTRY_NUMBER_OUTPUT

SJC\$_CREATE_QUEUE

This request creates a queue. If the queue already exists and is not stopped, this request performs no operation. However, if the queue already exists and is stopped, the request alters the parameters of the queue based on the item codes specified in the request; if you specify the SJC\$_CREATE_START item code, the request starts the queue.

You must specify the following input value item code:

SJC\$_QUEUE

You can specify the following input value or Boolean item codes:

SJC\$_AUTOSTART_ON	—
SJC\$_BASE_PRIORITY	—
SJC\$_BATCH	SJC\$_NO_BATCH
SJC\$_CHARACTERISTIC_NAME	SJC\$_NO_CHARACTERISTICS
SJC\$_CHARACTERISTIC_NUMBER	—
SJC\$_CLOSE_QUEUE	—
SJC\$_CPU_DEFAULT	SJC\$_NO_CPU_DEFAULT
SJC\$_CPU_LIMIT	SJC\$_NO_CPU_LIMIT
SJC\$_CREATE_START	—
SJC\$_DEFAULT_FORM_NAME	—
SJC\$_DEFAULT_FORM_NUMBER	—
SJC\$_DEVICE_NAME	—
SJC\$_FILE_BURST	SJC\$_NO_FILE_BURST
SJC\$_FILE_BURST_ONE	—
SJC\$_FILE_FLAG	SJC\$_NO_FILE_FLAG
SJC\$_FILE_FLAG_ONE	—
SJC\$_FILE_TRAILER	SJC\$_NO_FILE_TRAILER
SJC\$_FILE_TRAILER_ONE	—
SJC\$_FORM_NAME	—
SJC\$_FORM_NUMBER	—
SJC\$_GENERIC_QUEUE	SJC\$_NO_GENERIC_QUEUE
SJC\$_GENERIC_SELECTION	SJC\$_NO_GENERIC_SELECTION
SJC\$_GENERIC_TARGET	—
SJC\$_JOB_BURST	SJC\$_NO_JOB_BURST
SJC\$_JOB_FLAG	SJC\$_NO_JOB_FLAG
SJC\$_JOB_LIMIT	—
SJC\$_JOB_RESET_MODULES	SJC\$_NO_JOB_RESET_MODULES
SJC\$_JOB_SIZE_MAXIMUM	SJC\$_NO_JOB_SIZE_MAXIMUM
SJC\$_JOB_SIZE_MINIMUM	SJC\$_NO_JOB_SIZE_MINIMUM
SJC\$_JOB_SIZE_SCHEDULING	SJC\$_NO_JOB_SIZE_SCHEDULING
SJC\$_JOB_TRAILER	SJC\$_NO_JOB_TRAILER
SJC\$_LIBRARY_SPECIFICATION	SJC\$_NO_LIBRARY_SPECIFICATION
SJC\$_OPEN_QUEUE	—
SJC\$_OWNER_UIC	—
SJC\$_PAGINATE	SJC\$_NO_PAGINATE

SJC\$_PRINTER	—
SJC\$_PROCESSOR	SJC\$_NO_PROCESSOR
SJC\$_PROTECTION	—
SJC\$_QUEUE_DESCRIPTION	SJC\$_NO_QUEUE_DESCRIPTION
SJC\$_QUEUE_MANAGER_NAME	—
SJC\$_RAD	SJC\$_NO_RAD
SJC\$_RECORD_BLOCKING	SJC\$_NO_RECORD_BLOCKING
SJC\$_RETAIN_ALL_JOBS	SJC\$_NO_RETAIN_JOBS
SJC\$_RETAIN_ERROR_JOBS	—
SJC\$_SCSNODE_NAME	—
SJC\$_SERVER	—
SJC\$_SWAP	SJC\$_NO_SWAP
SJC\$_TERMINAL	SJC\$_NO_TERMINAL
SJC\$_WSDEFAULT	SJC\$_NO_WSDEFAULT
SJC\$_WSEXTENT	SJC\$_NO_WSEXTENT
SJC\$_WSQUOTA	SJC\$_NO_WSQUOTA

SJC\$_DEASSIGN_QUEUE

This request deassigns a logical queue from an execution queue.

You must specify the following input value item code:

SJC\$_QUEUE

SJC\$_DEFINE_CHARACTERISTIC

This request defines a characteristic name and number and inserts this definition into the queue file. The characteristic name can be up to 31 characters in length. Each characteristic name must have a unique number in the range 0 to 127. If the characteristic name is already defined, the request alters the definition of the characteristic.

A job cannot execute on an execution queue unless the queue possesses all the characteristics possessed by the job; the queue can possess additional characteristics and the job will still execute.

You must specify the following input value item codes:

SJC\$_CHARACTERISTIC_NAME
SJC\$_CHARACTERISTIC_NUMBER

SJC\$_DEFINE_FORM

This request defines a form name and number, as well as other physical attributes of the paper stock used in printers, and inserts this definition into the system job queue file. If the form name is already defined, this request alters the definition of the form.

Forms are used only by output execution queues and print jobs. A print job cannot execute unless the stock name of a form specified for the queue is the same as the stock name specified for the job. The stock name of a form, which you specify by using the SJC\$_FORM_STOCK item code, specifies the

paper stock used by the printer. Other item codes specify printing parameters for a job such as the margins, length of paper, and so on.

Each form must have a unique number. Numbers can range from 0 to 9999. When a new queue file is created, the system supplies the definition of a form named DEFAULT with number 0 and default characteristics.

You must specify the following input value item codes:

SJC\$_FORM_NAME
SJC\$_FORM_NUMBER

You can specify the following input value or Boolean item codes:

SJC\$_FORM_DESCRIPTION	—
SJC\$_FORM_LENGTH	—
SJC\$_FORM_MARGIN_BOTTOM	—
SJC\$_FORM_MARGIN_LEFT	—
SJC\$_FORM_MARGIN_RIGHT	—
SJC\$_FORM_MARGIN_TOP	—
SJC\$_FORM_SETUP_MODULES	SJC\$_NO_FORM_SETUP_MODULES
SJC\$_FORM_SHEET_FEED	SJC\$_NO_FORM_SHEET_FEED
SJC\$_FORM_STOCK	—
SJC\$_FORM_TRUNCATE	SJC\$_NO_FORM_TRUNCATE
SJC\$_FORM_WIDTH	—
SJC\$_FORM_WRAP	SJC\$_NO_FORM_WRAP
SJC\$_PAGE_SETUP_MODULES	SJC\$_NO_PAGE_SETUP_MODULES

SJC\$_DELETE_CHARACTERISTIC

This request deletes the definition of a characteristic name.

You must specify the following input value item code:

SJC\$_CHARACTERISTIC_NAME

SJC\$_DELETE_FORM

This request deletes the definition of a form name. There must be no queues or jobs that reference the form.

You must specify the following input value item code:

SJC\$_FORM_NAME

SJC\$_DELETE_JOB

This request deletes a job from the system job queue file. If the job is currently executing, it is aborted. If you specify the SJC\$_QUEUE item code, the \$SNDJBC service verifies that the selected job entry exists on the specified queue before deleting the job.

You must specify the following input value item code:

SJC\$_ENTRY_NUMBER

You can specify the following input value item code:

SJC\$_QUEUE

If you specify the SJC\$_QUEUE item code, the \$SNDJBC service verifies that the selected job entry exists on the specified queue before deleting the job.

SJC\$_DELETE_QUEUE

This request deletes a queue and all of the jobs in the queue. The queue must be stopped, and there must be no other queues or jobs that reference the queue.

You must specify the following input value item code:

SJC\$_QUEUE**SJC\$_DELETE_QUEUE_MANAGER**

This request removes all references to the specified queue manager from the shared master file. It also deletes the queue and journal files associated with the queue manager. A queue manager must be stopped to be deleted.

You must specify the following input value item code:

SJC\$_QUEUE_MANAGER_NAME**SJC\$_DISABLE_AUTOSTART**

This request disables autostart on a node. By default, SJC\$_DISABLE_AUTOSTART affects the requesting node. To disable autostart on a node other than the node from which the \$SNDJBC request is sent, use the SJC\$_SCSNODE_NAME item code to specify the affected node.

Disabling autostart on a node forces the appropriate queue manager to perform these tasks:

- Prevent autostart queues from failing over to the node.
- Mark all of that queue manager's autostart queues on the node as “stop pending” in preparation for a planned shutdown, allowing jobs currently executing on the queues to complete.
- Force all autostart queues with failover lists to fail over to the next available node in the queue manager's failover list on which autostart is enabled. Each queue fails over when all jobs currently executing on any of that queue manager's queues on the node have completed.

You can specify the following input value item codes:

SJC\$_QUEUE_MANAGER_NAME**SJC\$_SCSNODE_NAME**

For more information, see the *VSI OpenVMS System Manager's Manual*.

SJC\$_ENABLE_AUTOSTART

This request notifies the appropriate queue manager process that a node has progressed sufficiently in its startup procedure that batch and print jobs should execute. By default, SJC\$_ENABLE_AUTOSTART affects the requesting node. To enable autostart on a node other than the node from which the \$SNDJBC

request is sent, use the SJC\$_SCSNODE_NAME item code to specify the affected node. Once autostart is enabled, the queue manager starts all autostart-active queues on the appropriate node.

When a node reboots, autostart is disabled until the SJC\$_ENABLE_AUTOSTART request is entered.

You can specify the following input value item codes:

SJC\$_QUEUE_MANAGER_NAME
SJC\$_SCSNODE_NAME

For more information, see the *VSI OpenVMS System Manager's Manual*.

SJC\$_ENTER_FILE

This request creates a job containing one file and places the job in the specified queue. To create a job with more than one file, you must make a sequence of calls to the \$SNDJBC service using the SJC\$_CREATE_JOB, SJC\$_ADD_FILE, and SJC\$_CLOSE_JOB function codes.

You must specify the following input value item code:

SJC\$_QUEUE

You must specify one of the following input value item codes:

SJC\$_FILE_IDENTIFICATION
SJC\$_FILE_SPECIFICATION

You can specify the following input value or Boolean item codes:

SJC\$_ACCOUNT_NAME	—
SJC\$_AFTER_TIME	SJC\$_NO_AFTER_TIME
SJC\$_CHARACTERISTIC_NAME	SJC\$_NO_CHARACTERISTICS
SJC\$_CHARACTERISTIC_NUMBER	—
SJC\$_CLI	SJC\$_NO_CLI
SJC\$_CPU_LIMIT	SJC\$_NO_CPU_LIMIT
SJC\$_DELETE_FILE	SJC\$_NO_DELETE_FILE
SJC\$_DOUBLE_SPACE	SJC\$_NO_DOUBLE_SPACE
SJC\$_FILE_BURST	SJC\$_NO_FILE_BURST
SJC\$_FILE_COPIES	—
SJC\$_FILE_FLAG	SJC\$_NO_FILE_FLAG
SJC\$_FILE_SETUP_MODULES	SJC\$_NO_FILE_SETUP_MODULES
SJC\$_FILE_TRAILER	SJC\$_NO_FILE_TRAILER
SJC\$_FIRST_PAGE	SJC\$_NO_FIRST_PAGE
SJC\$_FORM_NAME	—
SJC\$_FORM_NUMBER	—
SJC\$_HOLD	SJC\$_NO_HOLD
SJC\$_JOB_COPIES	—
SJC\$_JOB_DEFAULT_RETAIN	—
SJC\$_JOB_ERROR_RETAIN	—

SJC\$_JOB_NAME	—
SJC\$_JOB_RETAIN	—
SJC\$_JOB_RETAIN_TIME	—
SJC\$_LAST_PAGE	SJC\$_NO_LAST_PAGE
SJC\$_LOG_DELETE	SJC\$_NO_LOG_DELETE
SJC\$_LOG_QUEUE	—
SJC\$_LOG_SPECIFICATION	SJC\$_NO_LOG_SPECIFICATION
SJC\$_LOG_SPOOL	SJC\$_NO_LOG_SPOOL
SJC\$_LOWERCASE	SJC\$_NO_LOWERCASE
SJC\$_NOTE	SJC\$_NO_NOTE
SJC\$_NOTIFY	SJC\$_NO_NOTIFY
SJC\$_OPERATOR_REQUEST	SJC\$_NO_OPERATOR_REQUEST
SJC\$_PAGE_HEADER	SJC\$_NO_PAGE_HEADER
SJC\$_PAGINATE	SJC\$_NO_PAGINATE
SJC\$_PARAMETER_1 through 8	SJC\$_NO_PARAMETERS
SJC\$_PASSALL	SJC\$_NO_PASSALL
SJC\$_PRIORITY	—
SJC\$_RAD	SJC\$_NO_RAD
SJC\$_RESTART	SJC\$_NO_RESTART
SJC\$_UIC	—
SJC\$_USERNAME	—
SJC\$_WSDEFAULT	SJC\$_NO_WSDEFAULT
SJC\$_WSEXTENT	SJC\$_NO_WSEXTENT
SJC\$_WSQUOTA	SJC\$_NO_WSQUOTA

You can specify the following output value item codes:

SJC\$_ENTRY_NUMBER_OUTPUT
SJC\$_JOB_STATUS_OUTPUT

SJC\$_MERGE_QUEUE

This request requeues all jobs in the queue specified by the item code SJC\$_QUEUE to the queue specified by the item code SJC\$_DESTINATION_QUEUE. The execution of current jobs is unaffected.

You must specify the following input value item codes:

SJC\$_DESTINATION_QUEUE
SJC\$_QUEUE

SJC\$_PAUSE_QUEUE

This request pauses the execution of current jobs in the specified queue and prevents the starting of jobs in that queue.

You must specify the following input value item code:

SJC\$_QUEUE

SJC\$_RESET_QUEUE

This request resets the specified queue by (1) terminating and deleting each executing job that is not restartable, (2) terminating and requeuing each executing job that is restartable, and (3) stopping the queue.

You must specify the following input value item code:

SJC\$_QUEUE

SJC\$_START_ACCOUNTING

This request performs two functions. If you specify the SJC\$_ACCOUNTING_TYPES item code, the request enables recording of the specified types of accounting records; if you do not specify SJC\$_ACCOUNTING_TYPES, the request starts the accounting manager and opens the system accounting file.

You can specify the following input value or Boolean item codes:

SJC\$_ACCOUNTING_TYPES

SJC\$_NEW_VERSION

SJC\$_START_QUEUE

This request permits the starting of jobs in the specified queue. If the queue was paused, current jobs are resumed.

You must specify the following input value item code:

SJC\$_QUEUE

You can specify the following input value or Boolean item codes:

SJC\$_ALIGNMENT_MASK	—
SJC\$_ALIGNMENT_PAGES	—
SJC\$_AUTOSTART_ON	—
SJC\$_BASE_PRIORITY	—
SJC\$_BATCH	SJC\$_NO_BATCH
SJC\$_CHARACTERISTIC_NAME	SJC\$_NO_CHARACTERISTICS
SJC\$_CHARACTERISTIC_NUMBER	—
SJC\$_CLOSE_QUEUE	—
SJC\$_CPU_DEFAULT	SJC\$_NO_CPU_DEFAULT
SJC\$_CPU_LIMIT	SJC\$_NO_CPU_LIMIT
SJC\$_DEFAULT_FORM_NAME	—
SJC\$_DEFAULT_FORM_NUMBER	—
SJC\$_DEVICE_NAME	—
SJC\$_FILE_BURST	SJC\$_NO_FILE_BURST
SJC\$_FILE_BURST_ONE	—

SJC\$_FILE_FLAG	SJC\$_NO_FILE_FLAG
SJC\$_FILE_FLAG_ONE	—
SJC\$_FILE_TRAILER	SJC\$_NO_FILE_TRAILER
SJC\$_FILE_TRAILER_ONE	—
SJC\$_FORM_NAME	—
SJC\$_FORM_NUMBER	—
SJC\$_GENERIC_QUEUE	SJC\$_NO_GENERIC_QUEUE
SJC\$_GENERIC_SELECTION	SJC\$_NO_GENERIC_SELECTION
SJC\$_GENERIC_TARGET	—
SJC\$_JOB_BURST	SJC\$_NO_JOB_BURST
SJC\$_JOB_FLAG	SJC\$_NO_JOB_FLAG
SJC\$_JOB_LIMIT	—
SJC\$_JOB_RESET_MODULES	SJC\$_NO_JOB_RESET_MODULES
SJC\$_JOB_SIZE_MAXIMUM	SJC\$_NO_JOB_SIZE_MAXIMUM
SJC\$_JOB_SIZE_MINIMUM	SJC\$_NO_JOB_SIZE_MINIMUM
SJC\$_JOB_SIZE_SCHEDULING	SJC\$_NO_JOB_SIZE_SCHEDULING
SJC\$_JOB_TRAILER	SJC\$_NO_JOB_TRAILER
SJC\$_LIBRARY_SPECIFICATION	SJC\$_NO_LIBRARY_SPECIFICATION
SJC\$_NEXT_JOB	—
SJC\$_OPEN_QUEUE	—
SJC\$_OWNER_UIC	—
SJC\$_PAGINATE	SJC\$_NO_PAGINATE
SJC\$_PROCESSOR	SJC\$_NO_PROCESSOR
SJC\$_PROTECTION	—
SJC\$_QUEUE_DESCRIPTION	SJC\$_NO_QUEUE_DESCRIPTION
SJC\$_RAD	SJC\$_NO_RAD
SJC\$_RECORD_BLOCKING	SJC\$_NO_RECORD_BLOCKING
SJC\$_RELATIVE_PAGE	—
SJC\$_RETAIN_ALL_JOBS	SJC\$_NO_RETAIN_JOBS
SJC\$_RETAIN_ERROR_JOBS	—
SJC\$_SCSNODE_NAME	—
SJC\$_SEARCH_STRING	—
SJC\$_SWAP	SJC\$_NO_SWAP
SJC\$_TERMINAL	SJC\$_NO_TERMINAL
SJC\$_TOP_OF_FILE	—
SJC\$_WSDEFAULT	SJC\$_NO_WSDEFAULT
SJC\$_WSEXTENT	SJC\$_NO_WSEXTENT
SJC\$_WSQUOTA	SJC\$_NO_WSQUOTA

SJC\$_START_QUEUE_MANAGER

This request starts the clusterwide queue manager for the batch and print queuing system. It also opens the queue database.

The `SJC$_START_QUEUE_MANAGER` request has the following five uses:

- To create a queue database and initially start the queue manager, issue a `SJC$_START_QUEUE_MANAGER` request with the `SJC$_NEW_VERSION` item code. See the description of the `SJC$_NEW_VERSION` item code for more information. Once the queue manager has been started, it will remain running unless it is explicitly stopped with an `SJC$_STOP_QUEUE_MANAGER` request.
- If an `SJC$_STOP_QUEUE_MANAGER` request has been specified, issue a `SJC$_START_QUEUE_MANAGER` request to restart the queue manager.
- In an OpenVMS Cluster environment, issue an `SJC$_START_QUEUE_MANAGER` request with the `SJC$_QUEUE_MANAGER_NODES` item code to modify the list of preferred nodes on which the queue manager can run. See the description of the `SJC$_QUEUE_MANAGER_NODES` item code for more information.
- In a cluster, issue an `SJC$_START_QUEUE_MANAGER` request to ensure that the queue manager process is executing on the most preferred, available node. If the queue manager is not running on the most preferred, available node, the queue manager will be moved to that node without interruption of service. If you are using the default node list (*), the queue manager will not move. For more information, see the description of the `SJC$_QUEUE_MANAGER_NODES` item code.
- To create additional queue managers, issue an `SJC$_START_QUEUE_MANAGER` request with the `SJC$_ADD_QUEUE_MANAGER` and `SJC$_QUEUE_MANAGER_NAME` item codes. Note that the queue manager name must be different from the name of any queue manager currently defined. For more information about creating multiple queue managers, see the *VSI OpenVMS System Manager's Manual*.

You can specify the following input value or Boolean item codes:

`SJC$_ADD_QUEUE_MANAGER`
`SJC$_NEW_VERSION`
`SJC$_QUEUE_DIRECTORY`
`SJC$_QUEUE_MANAGER_NAME`
`SJC$_QUEUE_MANAGER_NODES`

`SJC$_STOP_ACCOUNTING`

This request performs two functions. If you specify the `SJC$_ACCOUNTING_TYPES` item code, the request disables recording of the specified types of accounting records. If you do not specify `SJC$_ACCOUNTING_TYPES`, the request stops the accounting manager and closes the system accounting file.

You can specify the following input value item code:

`SJC$_ACCOUNTING_TYPES`

`SJC$_STOP_ALL_QUEUES_ON_NODE`

This request stops all queues on a specific node. By default, all queues on the requesting node are stopped. To stop all queues on a node other than the node from which the `$$NDJBC` request is sent, use the `SJC$_SCSNODE_NAME` item code to specify the affected node.

Besides stopping all queues on a specific node, this request aborts each job that is currently executing. Aborted jobs that are restartable are requeued. Queues for which an autostart list has been specified fail over to the first available node in the list for which autostart is enabled.

You can specify the following input value item codes:

SJC\$_QUEUE_MANAGER_NAME
SJC\$_SCSNODE_NAME

SJC\$_STOP_QUEUE

This request prevents the starting of jobs in the specified queue. The execution of current jobs is unaffected.

You must specify the following input value item code:

SJC\$_QUEUE

SJC\$_STOP_QUEUE_MANAGER

This request shuts down the appropriate queue manager. It disables autostart on all nodes; stops all queues; aborts each job that is currently executing, requeuing those jobs that are restartable; and closes the files of the queue database.

You can specify the following input value item code:

SJC\$_QUEUE_MANAGER_NAME

SJC\$_SYNCHRONIZE_JOB

This request waits for the completion of a job, then sets the event flag, executes the completion AST if you specified *astadr*, and returns the completion status of the job to the I/O Status Block, provided you specified the *iosb* argument.

You must specify one of the following input value item codes:

SJC\$_ENTRY_NUMBER
SJC\$_QUEUE

If SJC\$_QUEUE queue is specified, then you must also specify one of the following:

SJC\$_ENTRY_NUMBER
SJC\$_JOB_NAME

You can specify the following output value item code:

SJC\$_JOB_COMPLETION_STATUS

SJC\$_WRITE_ACCOUNTING

This request writes an accounting record.

You must specify the following input value item code:

SJC\$_ACCOUNTING_MESSAGE

Item Codes

SJC\$_ACCOUNT_NAME

The SJC\$_ACCOUNT_NAME item code is an input value item code. It specifies the account name of the user on behalf of whom the request is made. The buffer must specify a string from 1 to 8 characters. By default, the account name for batch and print jobs is taken from the requesting process.

You need CMKRNL privilege to use this item code.

(Valid for SJC\$_CREATE_JOB, SJC\$_ENTER_FILE function codes)

SJC\$_ACCOUNTING_MESSAGE

The SJC\$_ACCOUNTING_MESSAGE item code is an input value item code. It causes the contents of the buffer to be placed in a “user message” accounting record. The buffer must specify a string from 1 to 255 characters.

(Valid for SJC\$_WRITE_ACCOUNTING function code)

SJC\$_ACCOUNTING_TYPES

The SJC\$_ACCOUNTING_TYPES item code is an input value item code. It enables or disables accounting-record types. When an accounting-record type is enabled, the event designated by that type will be recorded in the accounting record. The buffer must contain a longword bit vector wherein each bit set specifies an accounting-record type. Undefined bits must be 0.

The \$\$JCDEF macro defines the symbolic names for the accounting-record types. Following is a list of each accounting-record type and the system event to which it corresponds.

Accounting-Record Type	Corresponding System Event
SJC\$V_ACCT_IMAGE	Image terminations
SJC\$V_ACCT_LOGIN_FAILURE	Login failures
SJC\$V_ACCT_MESSAGE	User messages sent
SJC\$V_ACCT_PRINT	Print job terminations
SJC\$V_ACCT_PROCESS	Process terminations

The following accounting-record types, when enabled, provide additional information about image and process termination; specifically, they describe the type of image or process that has terminated.

Accounting-Record Type	Type of Image or Process
SJC\$V_ACCT_BATCH	Batch process
SJC\$V_ACCT_DETACHED	Detached process
SJC\$V_ACCT_INTERACTIVE	Interactive process
SJC\$V_ACCT_NETWORK	Network process
SJC\$V_ACCT_SUBPROCESS	Subprocess

(Valid for SJC\$_START_ACCOUNTING, SJC\$_STOP_ACCOUNTING function codes)

SJC\$_ADD_QUEUE_MANAGER

The `SJC$_ADD_QUEUE_MANAGER` item code is a Boolean item code. It specifies that a new queue manager process should be defined in the master file. The operating system allows no more than five queue managers in a cluster.

(Valid for `SJC$_START_QUEUE_MANAGER` function code)

`SJC$_AFTER_TIME`
`SJC$_NO_AFTER_TIME`

The `SJC$_AFTER_TIME` item code is an input value item code. It specifies that the job can execute only if the system time is greater than or equal to the quadword time value contained in the buffer. The buffer must contain either an absolute time value or a delta time value; `$SNDJBC` converts delta time values to absolute time values by adding the current system time. The time value specified must be in the future, or it will be set to the current time.

The `SJC$_NO_AFTER_TIME` item code is a Boolean item code. It cancels the effect of a `SJC$_AFTER_TIME` item code previously specified for the job; the job can execute immediately. It is the default.

(Valid for `SJC$_ALTER_JOB`, `SJC$_CREATE_JOB`, `SJC$_ENTER_FILE` function codes)

`SJC$_ALIGNMENT_MASK`

The `SJC$_ALIGNMENT_MASK` item code is a Boolean item code. It is meaningful only for output execution queues and only when the `SJC$_ALIGNMENT_PAGES` item code is also specified. The `SJC$_ALIGNMENT_MASK` item code causes the data printed on form alignment pages to be masked: all alphabetic characters are replaced with the letter X and all numeric characters with the number 9.

(Valid for `SJC$_START_QUEUE` function code)

`SJC$_ALIGNMENT_PAGES`

The `SJC$_ALIGNMENT_PAGES` item code is an input value item code. It is meaningful only for output execution queues. It specifies that the queue be placed in form-alignment state and that a number of alignment pages be printed. The buffer must contain a longword value in the range 1 to 20; this value specifies how many alignment pages are to be printed.

(Valid for `SJC$_START_QUEUE` function code)

`SJC$_AUTOSTART_ON`

The `SJC$_AUTOSTART_ON` item code is an input value item code. For a batch queue, it uses as its value a comma-separated list of the nodes on which the specified queue can be located. Each node name must be followed by a double colon (::).

For an output queue, it uses as its value a comma-separated list of the names of the nodes and devices to which the specified queue's output can be sent. Each node name must be followed by a double colon, and each device name can be followed by the optional colon [:].

By specifying this item code, you designate a queue as an autostart queue. If you specify more than one node name (within an OpenVMS Cluster environment), the queue can automatically fail over if the node on which the queue is running is removed from the cluster.

This item code cannot be used with the `SJC$_SCSNODE_NAME` and `SJC$_DEVICE_NAME` item codes.

For more information, see the *VSI OpenVMS System Manager's Manual*.

(Valid for SJC\$_CREATE_QUEUE, SJC\$_START_QUEUE function codes)

SJC\$_BASE_PRIORITY

The SJC\$_BASE_PRIORITY item code is an input value item code. It is meaningful only for execution queues. It specifies the base priority of batch processes initiated from a batch execution queue or of a symbiont process connected to an output execution queue. A symbiont process can control several queues; however, the base priority of the symbiont process is established by the first queue to which it is connected. The buffer must contain a longword value in the range 0 to 15; this value specifies the base priority.

By default, the base priority is the value of the SYSGEN parameter DEFPRI.

(Valid for SJC\$_ALTER_QUEUE, SJC\$_CREATE_QUEUE, SJC\$_START_QUEUE function codes)

SJC\$_BATCH

SJC\$_NO_BATCH

The SJC\$_BATCH item code is a Boolean item code. It specifies that the queue is a batch execution queue or a generic batch queue, and thus can process only batch jobs.

The SJC\$_BATCH, SJC\$_PRINTER, SJC\$_SERVER, and SJC\$_TERMINAL item codes are mutually exclusive. If none of these item codes are specified, the default is SJC\$_PRINTER.

The SJC\$_NO_BATCH item code is a Boolean item code. It specifies that the queue is not a batch queue but rather an output execution or generic output queue, and thus can process only print jobs. It is the default.

For the SJC\$_START_QUEUE function code, SJC\$_BATCH and SJC\$_NO_BATCH are supported for compatibility with VAX/VMS Version 4.n, but might not be supported in the future.

(Valid for SJC\$_CREATE_QUEUE, SJC\$_START_QUEUE function codes)

SJC\$_CHARACTERISTIC_NAME

SJC\$_CHARACTERISTIC_NUMBER

SJC\$_NO_CHARACTERISTICS

The SJC\$_CHARACTERISTIC_NAME and SJC\$_CHARACTERISTIC_NUMBER item codes are both input value item codes. Both specify characteristics for jobs or queues, and they can be used interchangeably. The characteristics are user-defined.

The SJC\$_DEFINE_CHARACTERISTIC and SJC\$_DELETE_CHARACTERISTIC function codes include and delete, respectively, a specified characteristic from the system job queue file. A job cannot execute on an execution queue unless the queue possesses all the characteristics possessed by the job; the queue can possess additional characteristics and the job will still execute.

The SJC\$_CHARACTERISTIC_NAME and SJC\$_CHARACTERISTIC_NUMBER item codes can appear as many times as necessary in a single call to \$SNDJBC; the set of characteristics so defined in the call completely replaces the set of characteristics defined by a prior call. The SJC\$_NO_CHARACTERISTICS item code cancels all defined characteristics for the job or queue. By default, a queue or job has no defined characteristics.

The string can contain uppercase or lowercase characters (lowercase are converted to uppercase), numeric characters, dollar signs (\$), and underscores (_). If the string is a logical name, SYSSNDJBC

translates it iteratively until the equivalence string is found or the number of translations allowed by the system has been performed. The maximum length of the final character string is 31 characters; spaces, tabs, and null characters are ignored.

For `SJC$_CHARACTERISTIC_NUMBER`, the buffer must contain a longword value in the range 0 to 127. This number identifies a characteristic.

`SJC$_NO_CHARACTERISTICS` is a Boolean item code.

(The following function codes are valid for `SJC_CHARACTERISTIC_NAME` item code:

`SJC$_ALTER_JOB`
`SJC$_ALTER_QUEUE`
`SJC$_CREATE_JOB`
`SJC$_CREATE_QUEUE`
`SJC$_DEFINE_CHARACTERISTIC`
`SJC$_DELETE_CHARACTERISTIC`
`SJC$_ENTER_FILE`
`SJC$_START_QUEUE`)

(The following function codes are valid for `SJC$_CHARACTERISTIC_NUMBER` item code:

`SJC$_ALTER_JOB`
`SJC$_ALTER_QUEUE`
`SJC$_CREATE_JOB`
`SJC$_CREATE_QUEUE`
`SJC$_DEFINE_CHARACTERISTIC`
`SJC$_ENTER_FILE`
`SJC$_START_QUEUE`)

`SJC$_CHECKPOINT_DATA`

The `SJC$_CHECKPOINT_DATA` item code is an input value item code. It specifies the value of the DCL symbol `BATCH$RESTART` for a batch job that is restarted. The buffer must contain a string no longer than 255 characters; this string is the value of the symbol `BATCH$RESTART`.

(Valid for `SJC$_BATCH_CHECKPOINT` function code)

`SJC$_NO_CHECKPOINT_DATA`

The `SJC$_NO_CHECKPOINT_DATA` item code is a Boolean item code. It cancels a previous specification of the `BATCH$RESTART` symbol; the `SJC$_NO_CHECKPOINT_DATA` item code also cancels a checkpoint in a print job so that the entire job is reprinted. By default, the `BATCH$RESTART` symbol is undefined.

(Valid for `SJC$_ALTER_JOB` function code)

`SJC$_CLI` `SJC$_NO_CLI`

The `SJC$_CLI` item code is an input value item code. It is meaningful only for batch jobs. It specifies that the command language interpreter to be executed is `SYSSYSTEM:name.EXE`, where *name* is a valid OpenVMS RMS file name. The buffer must specify a name string from 1 to 39 characters.

The `SJC$_NO_CLI` item code is a Boolean item code. It specifies that the command language interpreter to be executed is the one specified in the user authorization file. It is the default.

(Valid for SJC\$_ALTER_JOB, SJC\$_CREATE_JOB, SJC\$_ENTER_FILE function codes)

SJC\$_CLOSE_QUEUE

The SJC\$_CLOSE_QUEUE item code is a Boolean item code. It specifies that jobs cannot be entered in the queue. If the queue is closed, you can specify the SJC\$_OPEN_QUEUE item code to permit jobs to be entered in the queue. By default, the queue is open.

Whether a queue is open or closed is independent of any other queue states (such as paused, stalled, stopped).

(Valid for SJC\$_ALTER_QUEUE, SJC\$_CREATE_QUEUE, SJC\$_START_QUEUE function codes)

SJC\$_CPU_DEFAULT

SJC\$_NO_CPU_DEFAULT

The SJC\$_CPU_DEFAULT item code is an input value item code. It is meaningful only for batch execution queues. It specifies the default CPU time limit in 10-millisecond units. The buffer contains this longword value. The value 0 specifies unlimited CPU time. You can specify a value that represents up to 497 days of CPU time.

The SJC\$_NO_CPU_DEFAULT item code is a Boolean item code. It is meaningful only for batch execution queues. It specifies that no default CPU time limit is to apply to the job. It is the default.

A CPU time limit for the process is included in each user record in the system user authorization file (UAF). You can also specify any or all of the following: a CPU time limit for individual jobs, a default CPU time limit for all jobs in a given queue, and a maximum CPU time limit for all jobs in a given queue. Table 12 shows the action taken when you specify a value for SJC\$_CPU_DEFAULT.

Table 12. CPU Time Limit Decision Table

CPU Time Limit Specified for Job?	Default CPU Time Limit Specified for Queue?	Maximum CPU Time Specified for Queue?	Action Taken
No	No	No	Use UAF value
Yes	No	No	Use smaller of job's limit and UAF value
Yes	Yes	No	Use smaller of job's limit and UAF value
Yes	No	Yes	Use smaller of job's limit and maximum
Yes	Yes	Yes	Use smaller of job's limit and maximum
No	Yes	Yes	Use smaller of queue's default and maximum
No	No	Yes	Use maximum
No	Yes	No	Use smaller of UAF value and queue's default

(Valid for SJC\$_ALTER_QUEUE, SJC\$_CREATE_QUEUE, SJC\$_START_QUEUE function codes)

SJC\$_CPU_LIMIT

SJC\$_NO_CPU_LIMIT

The SJC\$_CPU_LIMIT item code is an input value item code. It is meaningful only for batch execution queues and batch jobs. It specifies the maximum CPU time limit for batch jobs in 10-millisecond units.

The buffer must contain this longword value. The value 0 specifies unlimited CPU time. You can specify a value that represents up to 497 days of CPU time.

The `SJC$_NO_CPU_LIMIT` item code is a Boolean item code. It is meaningful only for batch execution queues and batch jobs. It specifies that no maximum CPU time limit is to apply to the job. It is the default.

For information about the action taken when you specify a value for `SJC$_CPU_LIMIT`, refer to the description of the `SJC$_CPU_DEFAULT` item code and to Table 12.

(Valid for `SJC$_ALTER_JOB`, `SJC$_ALTER_QUEUE`, `SJC$_CREATE_JOB`, `SJC$_CREATE_QUEUE`, `SJC$_ENTER_FILE`, `SJC$_START_QUEUE` function codes)

`SJC$_CREATE_START`

The `SJC$_CREATE_START` item code is a Boolean item code. It specifies that a queue be started after it is created. By default, a queue remains stopped after it is created.

(Valid for `SJC$_CREATE_QUEUE` function code)

`SJC$_DEFAULT_FORM_NAME` `SJC$_DEFAULT_FORM_NUMBER`

The `SJC$_DEFAULT_FORM_NAME` and `SJC$_DEFAULT_FORM_NUMBER` item codes are input value item codes. They specify the default form for a specific output queue by name and by number, respectively.

When you specify a default form for an output queue, the queue uses the queue-specific default form, rather than the systemwide default form, to process any job that does not explicitly specify a form.

For `SJC$_DEFAULT_FORM_NAME`, the buffer must specify a form name. The string can contain uppercase or lowercase characters (lowercase are converted to uppercase), numeric characters, dollar signs (\$), and underscores (_). If the string is a logical name, `SYSSNDJBC` translates it iteratively until the equivalence string is found or the number of translations allowed by the system has been performed. The maximum length of the final character string is 31 characters; spaces, tabs, and null characters are ignored.

For `SJC$_DEFAULT_FORM_NUMBER`, the buffer must specify a longword value. You should use only one of these item codes to identify a default form for the queue.

(Valid for `SJC$_ALTER_QUEUE`, `SJC$_CREATE_QUEUE`, `SJC$_START_QUEUE` function codes)

`SJC$_DELETE_FILE` `SJC$_NO_DELETE_FILE`

The `SJC$_DELETE_FILE` item code is a Boolean item code. It specifies that a file should be deleted after the job completes. The file that is deleted is the batch or print file submitted for execution. You cannot specify this item code with the `SJC$_ALTER_JOB` function code, which alters the parameters for an already existing job; you can make a file deletion request only when a job is first submitted to the queue.

The `SJC$_NO_DELETE_FILE` item code is a Boolean item code. It specifies that a file should not be deleted after execution of the job. It is the default. You can specify this item code with the `SJC$_ALTER_JOB` function code; this makes it possible to cancel a file deletion request that was made when the job was first submitted to the queue.

(Valid for SJC\$_ADD_FILE, SJC\$_ENTER_FILE function codes)

SJC\$_DESTINATION_QUEUE

The SJC\$_DESTINATION_QUEUE item code is an input value item code. When you specify the SJC\$_ASSIGN_QUEUE function code, SJC\$_DESTINATION_QUEUE specifies the name of the execution queue to which the logical queue is assigned. When you specify the SJC\$_ABORT_JOB, SJC\$_ALTER_JOB, or SJC\$_MERGE_QUEUE function code, SJC\$_DESTINATION_QUEUE specifies the name of the queue into which jobs are placed. By default, jobs remain in the original queue.

The string can contain uppercase or lowercase characters (lowercase are converted to uppercase), numeric characters, dollar signs (\$), and underscores (_). If the string is a logical name, SYSSNDJBC translates it iteratively until the equivalence string is found or the number of translations allowed by the system has been performed. The maximum length of the final character string is 31 characters; spaces, tabs, and null characters are ignored.

(Valid for SJC\$_ABORT_JOB, SJC\$_ALTER_JOB, SJC\$_ASSIGN_QUEUE, and SJC\$_MERGE_QUEUE function codes)

SJC\$_DEVICE_NAME

The SJC\$_DEVICE_NAME item code is an input value item code. It specifies the name of the device managed by the output execution queue. The buffer must specify a string from 1 to 255 characters. In an OpenVMS Cluster environment, the SJC\$_SCSNODE_NAME item code is used to specify the name of the node on which the device is located.

This item code cannot be used with the SJC\$_AUTOSTART_ON item code.

(Valid for SJC\$_CREATE_QUEUE, SJC\$_START_QUEUE function codes)

SJC\$_DOUBLE_SPACE

SJC\$_NO_DOUBLE_SPACE

The SJC\$_DOUBLE_SPACE item code is a Boolean item code. It is meaningful only for output execution queues. It specifies that the symbiont should print the file with double spacing.

The SJC\$_NO_DOUBLE_SPACE item code is a Boolean item code. It specifies that the symbiont should print the file with single spacing. It is the default.

(Valid for SJC\$_ADD_FILE, SJC\$_ALTER_JOB, SJC\$_ENTER_FILE function codes)

SJC\$_ENTRY_NUMBER

The SJC\$_ENTRY_NUMBER item code is an input value item code. It specifies the entry number of the job on which to perform the function. The buffer must contain this entry number.

(Valid for SJC\$_ABORT_JOB, SJC\$_ALTER_JOB, SJC\$_DELETE_JOB, SJC\$_SYNCHRONIZE_JOB function codes)

SJC\$_ENTRY_NUMBER_OUTPUT

The SJC\$_ENTRY_NUMBER_OUTPUT item code is an output value item code. The buffer must specify a longword into which \$SNDJBC will write the entry number of a created job.

(Valid for SJC\$_CREATE_JOB, SJC\$_ENTER_FILE function codes)

SJC\$_FILE_BURST
SJC\$_FILE_BURST_ONE
SJC\$_NO_FILE_BURST

The SJC\$_FILE_BURST item code is a Boolean item code. It is meaningful only for output execution queues. It specifies that burst and flag pages are to be printed preceding a file. If you specify SJC\$_FILE_BURST for a job, it specifies the default for all files in the job; if you specify it for an output execution queue, it specifies the default for all jobs executed from that queue.

The SJC\$_FILE_BURST_ONE item code is a Boolean item code. It is meaningful only for output execution queues. It specifies that a burst page is to be printed preceding a file. If you specify SJC\$_FILE_BURST_ONE for a job, this item code specifies that a burst page is to be printed preceding only the first copy of the first file in the job; if you specify SJC\$_FILE_BURST_ONE for an output execution queue, the item code specifies this behavior as the default for all jobs executed from that queue.

The SJC\$_NO_FILE_BURST item code is a Boolean item code. It is meaningful only for output execution queues. It specifies that no burst page should be printed. It is the default.

(The following function codes are valid for SJC\$_FILE_BURST item code:

SJC\$_ADD_FILE
SJC\$_ALTER_JOB
SJC\$_ALTER_QUEUE
SJC\$_CREATE_JOB
SJC\$_CREATE_QUEUE
SJC\$_ENTER_FILE
SJC\$_START_QUEUE)

(The following function codes are valid for SJC\$_FILE_BURST_ONE item code:

SJC\$_ALTER_QUEUE
SJC\$_CREATE_JOB
SJC\$_CREATE_QUEUE
SJC\$_START_QUEUE)

SJC\$_FILE_COPIES

The SJC\$_FILE_COPIES item code is an input value item code. It is meaningful only for output execution queues. It specifies the number of times a file is printed. By default, a file is repeated once. The buffer must specify a longword value from 1 to 255; this value is the repeat count.

(Valid for SJC\$_ADD_FILE, SJC\$_ALTER_JOB, SJC\$_ENTER_FILE function codes)

SJC\$_FILE_FLAG
SJC\$_FILE_FLAG_ONE
SJC\$_NO_FILE_FLAG

The SJC\$_FILE_FLAG item code is a Boolean item code. It is meaningful only for output execution queues. It specifies that a flag page is to be printed preceding a file. If you specify SJC\$_FILE_FLAG for a job, this item code indicates the default for all files in the job; if you specify it for an output execution queue, SJC\$_FILE_FLAG indicates the default for all jobs executed from that queue.

The SJC\$_FILE_FLAG_ONE item code is a Boolean item code. It is meaningful only for output execution queues. It specifies that a flag page is to be printed preceding a file. If you specify

SJC\$_FILE_FLAG_ONE for a job, this item code specifies that a flag page is to be printed preceding only the first copy of the first file in the job; if you specify SJC\$_FILE_FLAG_ONE for an output execution queue, it indicates this behavior as the default for all jobs executed from that queue.

The SJC\$_NO_FILE_FLAG item code is a Boolean item code. It is meaningful only for output execution queues. It specifies that no flag page should be printed by default for jobs within the queue.

(The following function codes are valid for SJC\$_FILE_FLAG item code:

SJC\$_ADD_FILE
SJC\$_ALTER_JOB
SJC\$_ALTER_QUEUE
SJC\$_CREATE_JOB
SJC\$_CREATE_QUEUE
SJC\$_ENTER_FILE
SJC\$_START_QUEUE)

(The following function codes are valid for SJC\$_FLAG_ONE item code:

SJC\$_ALTER_QUEUE
SJC\$_CREATE_JOB
SJC\$_CREATE_QUEUE
SJC\$_START_QUEUE)

SJC\$_FILE_IDENTIFICATION

The SJC\$_FILE_IDENTIFICATION item code is an input value item code. It specifies the file to be processed. The buffer contains a 28-byte value that identifies the file to be processed. This value specifies (in order) the following three file-identification fields in the OpenVMS RMS NAM block: the 16-byte NAM\$T_DVI field, the 6-byte NAM\$W_FID field, and the 6-byte NAM\$W_DID field. These fields occur consecutively in the NAM block.

If you specify SJC\$_FILE_IDENTIFICATION, you must omit the SJC\$_FILE_SPECIFICATION item code.

(Valid for SJC\$_ADD_FILE, SJC\$_ENTER_FILE function codes)

SJC\$_FILE_SETUP_MODULES

SJC\$_NO_FILE_SETUP_MODULES

The SJC\$_FILE_SETUP_MODULES item code is an input value item code. It is meaningful only for output execution queues. It specifies that a list of text modules should be extracted from the device control library and copied to the printer before a file is printed. The buffer must contain a list of text module names, with a comma separating each name.

The SJC\$_NO_FILE_SETUP_MODULES item code is a Boolean item code. It is meaningful only for output execution queues. It specifies that no text modules should be copied before printing a file. It is the default.

(Valid for SJC\$_ADD_FILE, SJC\$_ALTER_JOB, SJC\$_ENTER_FILE function codes)

SJC\$_FILE_SPECIFICATION

The SJC\$_FILE_SPECIFICATION item code is an input value item code. It identifies the file to be processed. The buffer must contain the file specification of the file to be processed. The

\$SNDJBC service converts the file specification to the corresponding file identification and proceeds as if the SJC\$_FILE_IDENTIFICATION item code had been specified. If you specify SJC\$_FILE_SPECIFICATION, you must omit the SJC\$_FILE_IDENTIFICATION item code.

(Valid for SJC\$_ADD_FILE, SJC\$_ENTER_FILE function codes)

SJC\$_FILE_TRAILER
SJC\$_FILE_TRAILER_ONE
SJC\$_NO_FILE_TRAILER

The SJC\$_FILE_TRAILER item code is a Boolean item code. It is meaningful only for output execution queues. It specifies that a trailer page is to be printed following a file. If you specify SJC\$_FILE_TRAILER for a job, this item code indicates the default for all files in the job; if you specify it for an output execution queue, SJC\$_FILE_TRAILER specifies the default for all jobs executed on that queue.

The SJC\$_FILE_TRAILER_ONE item code is a Boolean item code. It is meaningful only for output execution queues. It specifies that a trailer page is to be printed following a file. If you specify SJC\$_FILE_TRAILER_ONE for a job, this item code indicates that a trailer page is to be printed following only the last copy of the last file in the job; if you specify it for an output execution queue, SJC\$_FILE_TRAILER_ONE indicates this behavior as the default for all jobs executed on that queue.

The SJC\$_NO_FILE_TRAILER item code is a Boolean item code. It is meaningful only for output execution queues. It specifies that no trailer page should be printed. It is the default.

(The following function codes are valid for SJC\$_FILE_TRAILER item code:

SJC\$_ADD_FILE
SJC\$_ALTER_JOB
SJC\$_ALTER_QUEUE
SJC\$_CREATE_JOB
SJC\$_CREATE_QUEUE
SJC\$_ENTER_FILE
SJC\$_START_QUEUE)

(The following function codes are valid for SJC\$_FILE_TRAILER_ONE item code:

SJC\$_ALTER_QUEUE
SJC\$_CREATE_JOB
SJC\$_CREATE_QUEUE
SJC\$_START_QUEUE)

SJC\$_FIRST_PAGE
SJC\$_NO_FIRST_PAGE

The SJC\$_FIRST_PAGE item code is an input value item code. It is meaningful only for jobs queued to output execution queues. It specifies the page number at which printing should begin. The buffer must contain a nonzero longword value specifying this page number.

The SJC\$_NO_FIRST_PAGE item code is a Boolean item code. It is meaningful only for jobs queued to output execution queues. It specifies that printing should begin with the first page. It is the default.

(Valid for SJC\$_ADD_FILE, SJC\$_ALTER_JOB, SJC\$_ENTER_FILE function codes)

SJC\$_FORM_DESCRIPTION

The `SJC$_FORM_DESCRIPTION` item code is an input value item code. It provides operator-supplied information describing the form. By default, the form name is used. The buffer must specify a string of no more than 255 characters.

(Valid for `SJC$_DEFINE_FORM` function code)

SJC\$_FORM_LENGTH

The `SJC$_FORM_LENGTH` item code is an input value item code. It specifies the physical length of the form in lines. The buffer must contain a nonzero longword integer value. By default, the form length is 66 lines.

(Valid for `SJC$_DEFINE_FORM` function code)

SJC\$_FORM_MARGIN_BOTTOM

The `SJC$_FORM_MARGIN_BOTTOM` item code is an input value item code. It specifies the bottom margin of the form in lines. By default, the bottom margin is 6 lines.

(Valid for `SJC$_DEFINE_FORM` function code)

SJC\$_FORM_MARGIN_LEFT

The `SJC$_FORM_MARGIN_LEFT` item code is an input value item code. It specifies the width of the left margin of the form in characters. By default, the left margin is 0. The buffer must specify a longword value.

(Valid for `SJC$_DEFINE_FORM` function code)

SJC\$_FORM_MARGIN_RIGHT

The `SJC$_FORM_MARGIN_RIGHT` item code is an input value item code. It specifies the width of the right margin of the form in characters. By default, the right margin is 0. The buffer must specify a longword value.

(Valid for `SJC$_DEFINE_FORM` function code)

SJC\$_FORM_MARGIN_TOP

The `SJC$_FORM_MARGIN_TOP` item code is an input value item code. It specifies the top margin of the form in lines. By default, the top margin is 0.

(Valid for `SJC$_DEFINE_FORM` function code)

SJC\$_FORM_NAME

SJC\$_FORM_NUMBER

The `SJC$_FORM_NAME` and `SJC$_FORM_NUMBER` item codes are input value item codes. They specify a mounted form for the queue by name and by number, respectively. For `SJC$_FORM_NAME`, the buffer must specify a form name. For `SJC$_FORM_NUMBER`, the buffer must specify a longword value. You should use only one of these two item codes to identify a form in queue and job related function codes.

The `SJC$_DEFINE_FORM` and `SJC$_DELETE_FORM` function codes include and delete, respectively, a specified form name and number from the system job queue file. The mounted form indicates the stock type of the output queue. A job cannot execute on an output queue unless the stock type of the form specified (by name or number) for the job item code is the same as the stock type of the mounted

form specified for the queue. For more information about how the stock type of a form affects job processing, see the *VSI OpenVMS System Manager's Manual*.

The string can contain uppercase or lowercase characters (lowercase are converted to uppercase), numeric characters, dollar signs (\$), and underscores (_). If the string is a logical name, SYSSNDJBC translates it iteratively until the equivalence string is found or the number of translations allowed by the system has been performed. The maximum length of the final character string is 31 characters; spaces, tabs, and null characters are ignored.

(The following function codes are valid for SJC\$_FORM_NAME item code:

SJC\$_ALTER_JOB
SJC\$_ALTER_QUEUE
SJC\$_CREATE_JOB
SJC\$_CREATE_QUEUE
SJC\$_DEFINE_FORM
SJC\$_DELETE_FORM
SJC\$_ENTER_FILE
SJC\$_START_QUEUE)

(The following function codes are valid for SJC\$_FORM_NUMBER item code:

SJC\$_ALTER_JOB
SJC\$_ALTER_QUEUE
SJC\$_CREATE_JOB
SJC\$_CREATE_QUEUE
SJC\$_DEFINE_FORM
SJC\$_ENTER_FILE
SJC\$_START_QUEUE)

SJC\$_FORM_SETUP_MODULES
SJC\$_NO_FORM_SETUP_MODULES

The SJC\$_FORM_SETUP_MODULES item code is an input value item code. The buffer must specify one or more text module names, with a comma separating each name. This item code specifies that these modules should be extracted from the device control library and copied to the printer before each file that is printed on the form.

The SJC\$_NO_FORM_SETUP_MODULES item code is a Boolean item code. It specifies that no device control modules should be copied. It is the default.

(Valid for SJC\$_DEFINE_FORM function code)

SJC\$_FORM_SHEET_FEED
SJC\$_NO_FORM_SHEET_FEED

The SJC\$_FORM_SHEET_FEED item code is a Boolean item code. It specifies that the symbiont should pause at the end of each physical page so that a new sheet can be inserted.

The SJC\$_NO_FORM_SHEET_FEED item code is a Boolean item code. It specifies that the output symbiont should not pause at the end of every physical page. It is the default.

(Valid for SJC\$_DEFINE_FORM function code)

SJC\$_FORM_STOCK

The `SJC$_FORM_STOCK` item code is an input value item code. It specifies a name for the paper stock. The buffer must contain a string of 1 to 31 characters. By default, the name of the paper stock is the form name.

(Valid for `SJC$_DEFINE_FORM` function code)

`SJC$_FORM_TRUNCATE`
`SJC$_NO_FORM_TRUNCATE`

The `SJC$_FORM_TRUNCATE` item code is a Boolean item code. It specifies that the symbiont should truncate lines that extend beyond the right margin. Specifying `SJC$_FORM_TRUNCATE` cancels `SJC$_FORM_WRAP`. The `SJC$_FORM_TRUNCATE` item code is the default.

The `SJC$_NO_FORM_TRUNCATE` item code is a Boolean item code. It specifies that the output symbiont should not truncate lines that extend beyond the right margin.

(Valid for `SJC$_DEFINE_FORM` function code)

`SJC$_FORM_WIDTH`

The `SJC$_FORM_WIDTH` item code is an input value item code. It specifies the physical width of the form in characters. The buffer must contain a nonzero longword integer. By default, the form width is 132 characters.

(Valid for `SJC$_DEFINE_FORM` function code)

`SJC$_FORM_WRAP`
`SJC$_NO_FORM_WRAP`

The `SJC$_FORM_WRAP` item code is a Boolean item code. It specifies that the symbiont should wrap lines that extend beyond the right margin. Specifying `SJC$_FORM_WRAP` cancels `SJC$_FORM_TRUNCATE`.

The `SJC$_NO_FORM_WRAP` item code is a Boolean item code. It specifies that the output symbiont should not wrap lines. It is the default.

(Valid for `SJC$_DEFINE_FORM` function code)

`SJC$_GENERIC_QUEUE`
`SJC$_NO_GENERIC_QUEUE`

The `SJC$_GENERIC_QUEUE` item code is a Boolean item code. It specifies that a queue is a generic queue.

The `SJC$_NO_GENERIC_QUEUE` item code is a Boolean item code. It specifies that a queue is not a generic queue. It is the default. By default, a queue is an execution queue; see the Description section for a full discussion of the types of queue.

(Valid for `SJC$_CREATE_QUEUE`, `SJC$_START_QUEUE` function codes)

`SJC$_GENERIC_SELECTION`
`SJC$_NO_GENERIC_SELECTION`

The `SJC$_GENERIC_SELECTION` item code is a Boolean item code. It specifies that an execution queue can accept jobs from a generic queue. It is the default. It is meaningful only for execution queues.

The `SJC$_NO_GENERIC_SELECTION` item code is a Boolean item code. It specifies that an execution queue cannot accept jobs from a generic queue.

(Valid for `SJC$_ALTER_QUEUE`, `SJC$_CREATE_QUEUE`, `SJC$_START_QUEUE` function codes)

SJC\$_GENERIC_TARGET

The `SJC$_GENERIC_TARGET` item code is an input value item code. The buffer must specify a queue name. This queue name identifies an execution queue that can accept jobs from a generic queue. This item code is meaningful only for generic queues.

This item code can appear up to 124 times in a single call to `$$NDJBC`. The set of queues defined in a single call completely replaces the set defined by a prior call.

The string can contain uppercase or lowercase characters (lowercase are converted to uppercase), numeric characters, dollar signs (\$), and underscores (_). If the string is a logical name, `SY$$NDJBC` translates it iteratively until the equivalence string is found or the number of translations allowed by the system has been performed. The maximum length of the final character string is 31 characters; spaces, tabs, and null characters are ignored.

(Valid for `SJC$_CREATE_QUEUE`, `SJC$_START_QUEUE` function codes)

SJC\$_HOLD

SJC\$_NO_HOLD

The `SJC$_HOLD` item code is a Boolean item code. It specifies that a job cannot execute and must enter a holding status.

The `SJC$_NO_HOLD` item code is a Boolean item code. It specifies that a job can execute immediately when used with the `SJC$_ALTER_JOB` function code. It makes the following types of job eligible for execution: (1) a job that is holding because it was specified with the `SJC$_HOLD` item code, (2) a job that was refused by the symbiont, and (3) a job that was retained after execution. It is the default. `SJC$_NO_HOLD` does not release a job that is specified with the `SJC$_AFTER_TIME` item code.

(Valid for `SJC$_ABORT_JOB`, `SJC$_ALTER_JOB`, `SJC$_CREATE_JOB`, `SJC$_ENTER_FILE` function codes)

SJC\$_JOB_BURST

SJC\$_NO_JOB_BURST

The `SJC$_JOB_BURST` item code is a Boolean item code. It specifies that burst and flag pages are to be printed preceding each job. It is meaningful only for output execution queues.

The `SJC$_NO_JOB_BURST` item code is a Boolean item code. It specifies that a burst page is not to be printed preceding each job. It is meaningful only for output execution queues. It is the default.

(Valid for `SJC$_ALTER_QUEUE`, `SJC$_CREATE_QUEUE`, `SJC$_START_QUEUE` function codes)

SJC\$_JOB_COMPLETION_STATUS

Output item code. Use this item code to receive the completion status of the job being synchronized. You can omit the `IOSB` in the `$$NDJBC` call and receive the completion status in this item's value.

(Valid for the `SJC$_SYNCHRONIZE_JOB` function code)

SJC\$_JOB_COPIES

The `SJC$_JOB_COPIES` item code is an input value item code. It specifies the number of times that the entire print job is to be repeated. The buffer must contain this nonzero longword integer value. By default, the print job is repeated once.

(Valid for `SJC$_ALTER_JOB`, `SJC$_CREATE_JOB`, `SJC$_ENTER_FILE` function codes)

SJC\$_JOB_DEFAULT_RETAIN

The `SJC$_JOB_DEFAULT_RETAIN` item code is a Boolean item code. It specifies that you want the job to be held in the queue as specified by the queue's retention policy.

For more information about user-specified job retention, see the `/RETAIN` qualifier for the `PRINT` or `SUBMIT` command in the *VSI OpenVMS DCL Dictionary*.

(Valid for `SJC$_ALTER_JOB`, `SJC$_CREATE_JOB`, `SJC$_ENTER_FILE` function codes)

SJC\$_JOB_ERROR_RETAIN

The `SJC$_JOB_ERROR_RETAIN` item code is a Boolean item code. It specifies that you want the job to be retained in the queue if the job completes unsuccessfully. However, the job might be held in the queue even if it completes successfully if the queue is set to retain all jobs because the `QUI$_QUEUE_RETAIN_ALL` bit is set in the `QUI$_QUEUE_FLAGS` item code.

For more information about user-specified job retention, see the `/RETAIN` qualifier for the `PRINT` or `SUBMIT` command in the *VSI OpenVMS DCL Dictionary*.

(Valid for `SJC$_ALTER_JOB`, `SJC$_CREATE_JOB`, `SCJ$_ENTER_FILE` function codes)

SJC\$_JOB_FLAG **SJC\$_NO_JOB_FLAG**

The `SJC$_JOB_FLAG` item code is a Boolean item code. It specifies that a flag page is to be printed preceding each job. It is meaningful only for output execution queues.

The `SJC$_NO_JOB_FLAG` item code is a Boolean item code. It specifies that a flag page is not to be printed preceding each job. It is meaningful only for output execution queues. It is the default.

(Valid for `SJC$_ALTER_QUEUE`, `SJC$_CREATE_QUEUE`, `SJC$_START_QUEUE` function codes)

SJC\$_JOB_LIMIT

The `SJC$_JOB_LIMIT` item code is an input value item code. It specifies the maximum number of jobs that can execute simultaneously on a queue. The buffer must contain a longword value in the range 1 to 65535. It is meaningful only for batch execution queues. By default, the job limit is 1.

(Valid for `SJC$_ALTER_QUEUE`, `SJC$_CREATE_QUEUE`, `SJC$_START_QUEUE` function codes)

SJC\$_JOB_NAME

The `SJC$_JOB_NAME` item code is an input value item code. It specifies the name of a job. The buffer must specify a string from 1 to 39 characters.

For function codes `SJC$_ENTER_FILE`, `SJC$_CREATE_JOB`, and `SJC$_ALTER_JOB`, `SJC$_JOB_NAME` specifies the identifying name of the job. By default, the name used is the name of the first file in the job.

For function code `SJC$_SYNCHRONIZE_JOB`, `SJC$_JOB_NAME` specifies the name of the job on which to operate. The job name is implicitly qualified by the user name.

(Valid for `SJC$_ALTER_JOB`, `SJC$_CREATE_JOB`, `SJC$_ENTER_FILE`, `SJC$_SYNCHRONIZE_JOB` function codes)

`SJC$_JOB_RESET_MODULES`
`SJC$_NO_JOB_RESET_MODULES`

The `SJC$_JOB_RESET_MODULES` item code is an input value item code. It is meaningful only for output execution queues. The buffer must specify the names of one or more text modules, with a comma separating each name. This item code specifies that these modules are to be extracted from the device control library and copied to the printer before each print job.

The `SJC$_NO_JOB_RESET_MODULES` item code is a Boolean item code. It specifies that no text modules should be copied to the printer. It is the default.

(Valid for `SJC$_ALTER_QUEUE`, `SJC$_CREATE_QUEUE`, `SJC$_START_QUEUE` function codes)

`SJC$_JOB_RETAIN`

The `SJC$_JOB_RETAIN` item code is a Boolean item code. It specifies that you want the job to be retained in the queue after it has executed, regardless of the job's completion status.

For more information about user-specified job retention, see the `/RETAIN` qualifier for the `PRINT` or `SUBMIT` command in the *VSI OpenVMS DCL Dictionary*.

(Valid for `SJC$_ALTER_JOB`, `SJC$_CREATE_JOB`, `SJC$_ENTER_FILE` function codes)

`SJC$_JOB_RETAIN_TIME`

The `SJC$_JOB_RETAIN_TIME` item code is an input value item code. It specifies a quadword time value representing the length of time you want the job to be retained in the queue.

If a delta time is provided, the delta begins when the job completes. However, depending on the queue's job retention policy, the job might be retained indefinitely.

For more information about user-specified job retention, see the `/RETAIN` qualifier for the `PRINT` or `SUBMIT` command in the *VSI OpenVMS DCL Dictionary*.

(Valid for `SJC$_ALTER_JOB`, `SJC$_CREATE_JOB`, `SJC$_ENTER_FILE` function codes)

`SJC$_JOB_SIZE_MAXIMUM`
`SJC$_NO_JOB_SIZE_MAXIMUM`

The `SJC$_JOB_SIZE_MAXIMUM` item code is an input value item code. It is meaningful only for output execution queues. It specifies that a print job can execute only if its total size in blocks is less than or equal to the specified value. The buffer specifies this nonzero longword value.

The `SJC$_NO_JOB_SIZE_MAXIMUM` item code is a Boolean item code. It specifies that a print job can execute immediately regardless of its size. It is the default.

(Valid for `SJC$_ALTER_QUEUE`, `SJC$_CREATE_QUEUE`, `SJC$_START_QUEUE` function codes)

`SJC$_JOB_SIZE_MINIMUM`

SJC\$_NO_JOB_SIZE_MINIMUM

The SJC\$_JOB_SIZE_MINIMUM item code is an input value item code. It is meaningful only for output execution queues. It specifies that a print job can execute only if its total size in blocks is greater than or equal to the specified value. The buffer specifies this nonzero longword value.

The SJC\$_NO_JOB_SIZE_MINIMUM item code is a Boolean item code. It specifies that a print job can execute immediately regardless of its size. It is the default.

(Valid for SJC\$_ALTER_QUEUE, SJC\$_CREATE_QUEUE, SJC\$_START_QUEUE function codes)

SJC\$_JOB_SIZE_SCHEDULING
SJC\$_NO_JOB_SIZE_SCHEDULING

The SJC\$_JOB_SIZE_SCHEDULING item code is a Boolean item code. It specifies that print jobs entered in an output queue should be scheduled according to size, with the smallest job of a given priority processed first. It is the default.

The SJC\$_NO_JOB_SIZE_SCHEDULING item code is a Boolean item code. It specifies that print jobs of a given priority should not be scheduled according to print size.

Changing the value of this item code for a queue while print jobs are pending on any queue produces unpredictable results.

(Valid for SJC\$_ALTER_QUEUE, SJC\$_CREATE_QUEUE, SJC\$_START_QUEUE function codes)

SJC\$_JOB_STATUS_OUTPUT

The SJC\$_JOB_STATUS_OUTPUT item code is an output value item code. When specified, \$SNDJBC returns, as a character string, a textual message describing the status of a submitted job. Because the message can include up to 255 characters, the buffer length field of the item descriptor should specify 255 (bytes).

(Valid for SJC\$_CLOSE_JOB, SJC\$_ENTER_FILE function codes)

SJC\$_JOB_TRAILER
SJC\$_NO_JOB_TRAILER

The SJC\$_JOB_TRAILER item code is a Boolean item code. It is meaningful only for output execution queues. It specifies that a trailer page is to be printed following each job.

The SJC\$_NO_JOB_TRAILER item code is a Boolean item code. It is meaningful only for output execution queues. It specifies that a trailer page is not to be printed following each job. It is the default.

(Valid for SJC\$_ALTER_QUEUE, SJC\$_CREATE_QUEUE, SJC\$_START_QUEUE function codes)

SJC\$_LAST_PAGE
SJC\$_NO_LAST_PAGE

The SJC\$_LAST_PAGE item code is an input value item code. It is meaningful only for jobs submitted to output execution queues. It specifies the page number at which printing should end. The buffer specifies this nonzero longword value.

The SJC\$_NO_LAST_PAGE item code is a Boolean item code. It specifies that printing should end after the last page. It is the default.

(Valid for SJC\$_ADD_FILE, SJC\$_ALTER_JOB, SJC\$_ENTER_FILE function codes)

SJC\$_LIBRARY_SPECIFICATION
SJC\$_NO_LIBRARY_SPECIFICATION

The SJC\$_LIBRARY_SPECIFICATION item code is an input value item code. It is meaningful only for output execution queues. It specifies that the device control library for the queue is SYSS\$LIBRARY:name.TLB, where *name* is a valid RMS file name. The buffer must specify the OpenVMS RMS file name.

The SJC\$_NO_LIBRARY_SPECIFICATION item code is a Boolean item code. It specifies that the device control library is SYSS\$LIBRARY:SYSDEVCTL.TLB. It is the default.

(Valid for SJC\$_CREATE_QUEUE, SJC\$_START_QUEUE function codes)

SJC\$_LOG_DELETE
SJC\$_NO_LOG_DELETE

The SJC\$_LOG_DELETE item code is a Boolean item code. It specifies that the log file produced for a batch job is to be deleted. It is meaningful only for batch jobs. It is the default.

The SJC\$_NO_LOG_DELETE item code is a Boolean item code. It specifies that the log file produced for a batch job is not to be deleted.

(Valid for SJC\$_ALTER_JOB, SJC\$_CREATE_JOB, SJC\$_ENTER_FILE function codes)

SJC\$_LOG_QUEUE

The SJC\$_LOG_QUEUE item code is an input value item code. It is meaningful only for batch jobs. It specifies the queue into which the log file produced for the batch job is entered for printing. The buffer must specify the name of the queue. By default, the log file is entered in queue SYSS\$PRINT.

The string can contain uppercase or lowercase characters (lowercase are converted to uppercase), numeric characters, dollar signs (\$), and underscores (_). If the string is a logical name, SYSS\$SNDJBC translates it iteratively until the equivalence string is found or the number of translations allowed by the system has been performed. The maximum length of the final character string is 31 characters; spaces, tabs, and null characters are ignored.

If your system uses multiple queue managers to run batch queues on a separate queue manager from output queues, certain checks that would otherwise be performed for the SJC\$_LOG_QUEUE item code of the \$SNDJBC system service are not performed.

When batch and print queues are managed by the same queue manager, the queue manager checks to ensure that the queue specified with the SJC\$_LOG_QUEUE is an output queue and that the user has access to the output queue. These checks are not made if the batch queue specified by the \$SNDJBC service and the output queue specified by the SJC\$_LOG_QUEUE item code are managed by different queue managers. If you explicitly specify an output queue for the log file when submitting a batch job, be sure the queue you specify with the SJC\$_LOG_QUEUE is an output queue and not a batch queue. Also, be sure that you have access to the printer queue.

(Valid for SJC\$_ALTER_JOB, SJC\$_CREATE_JOB, SJC\$_ENTER_FILE function codes)

SJC\$_LOG_SPECIFICATION
SJC\$_NO_LOG_SPECIFICATION

The `SJC$_LOG_SPECIFICATION` item code is an input value item code. It is meaningful only for batch jobs. It specifies the file specification of the log file produced for a batch job. The buffer must contain this OpenVMS RMS file specification. Omitted fields in the file specification are supplied from the default file specification `SY$LOGIN:name.LOG`, where *name* is the job name. By default a log file is produced using this default file specification to generate the log file name.

The `SJC$_NO_LOG_SPECIFICATION` item code is a Boolean item code. It specifies that no log file should be produced for the batch job.

(Valid for `SJC$_ALTER_JOB`, `SJC$_CREATE_JOB`, `SJC$_ENTER_FILE` function codes)

SJC\$_LOG_SPOOL **SJC\$_NO_LOG_SPOOL**

The `SJC$_LOG_SPOOL` item code is a Boolean item code. It specifies that the log file produced for a batch job is to be printed. It is meaningful only for batch jobs. It is the default.

The `SJC$_NO_LOG_SPOOL` item code is a Boolean item code. It specifies that the log file for a batch job is not to be printed.

(Valid for `SJC$_ALTER_JOB`, `SJC$_CREATE_JOB`, `SJC$_ENTER_FILE` function codes)

SJC\$_LOWERCASE **SJC\$_NO_LOWERCASE**

The `SJC$_LOWERCASE` item code is a Boolean item code. It specifies that a job can execute only on a device that has the `LOWERCASE` device-dependent characteristic. It is meaningful only for jobs submitted to output execution queues.

The `SJC$_NO_LOWERCASE` item code is a Boolean item code. It specifies that a job can execute whether or not the output device has the `LOWERCASE` device-dependent characteristic. It is the default.

(Valid for `SJC$_ALTER_JOB`, `SJC$_CREATE_JOB`, `SJC$_ENTER_FILE` function codes)

SJC\$_NEW_VERSION

The `SJC$_NEW_VERSION` item code is a Boolean item code.

When used with the `SJC$_START_QUEUE_MANAGER` function code, it specifies that a new (empty) version of the queue database is to be created, whether or not the database files already exist. This item code is required when initially creating and starting the queuing system, but it should be used with caution thereafter.

Caution

If you specify this item code and a queue database already exists, the new master and queue files of the queue database supersede existing version of those files. However, the journal files of the queue database are deleted. Thus, jobs and other information are lost.

When used with the `SJC$_START_ACCOUNTING` function code, the `SJC$_NEW_VERSION` item code specifies that a new version of the system accounting file is to be created, whether or not the file already exists.

(Valid for `SJC$_START_ACCOUNTING`, `SJC$_START_QUEUE_MANAGER` function codes)

SJC\$_NEXT_JOB

The SJC\$_NEXT_JOB item code is a Boolean item code. It is meaningful only for paused output execution queues. It specifies that the current job should be aborted and that printing should be resumed with the next job.

(Valid for SJC\$_START_QUEUE function code)

SJC\$_NOTE**SJC\$_NO_NOTE**

The SJC\$_NOTE item code is an input value item code. It is meaningful for batch and output execution queues. It specifies a string to be printed on the job flag and file flag pages. The buffer must specify this string.

The SJC\$_NO_NOTE item code is a Boolean item code. It specifies that no string is to be printed on the job flag and file flag pages. It is the default.

(Valid for SJC\$_ALTER_JOB, SJC\$_CREATE_JOB, SJC\$_ENTER_FILE function codes)

SJC\$_NOTIFY**SJC\$_NO_NOTIFY**

The SJC\$_NOTIFY item code is a Boolean item code. It specifies that a message is to be broadcast, at the time of job completion, to each logged-in terminal, of the user who submitted the job.

The SJC\$_NO_NOTIFY item code is a Boolean item code. It specifies that no message is to be broadcast at the time of job completion. It is the default.

(Valid for SJC\$_ALTER_JOB, SJC\$_CREATE_JOB, SJC\$_ENTER_FILE function codes)

SJC\$_NO_RAD (Alpha and Integrity servers)

Boolean input item code. When the SJC\$_NO_RAD code is specified in a request, the RAD value for the queue or job is removed.

RAD is supported on AlphaServer GS series systems and starting from OpenVMS Version 8.4, support is extended to NUMA capable Integrity servers.

(Valid for SJC\$_ALTER_JOB, SJC\$_ALTER_QUEUE, SJC\$_CREATE_JOB, SJC\$_CREATE_QUEUE, SJC\$_ENTER_FILE, SJC\$_START_QUEUE)

SJC\$_OPEN_QUEUE

The SJC\$_OPEN_QUEUE item code is a Boolean item code. It specifies that jobs can be entered in the queue. To specify that jobs cannot be entered in the queue, use the SJC\$_CLOSE_QUEUE item code. By default, the queue is open.

Whether a queue is open or closed is independent of any other queue states (such as paused, stalled, stopped).

(Valid for SJC\$_ALTER_QUEUE, SJC\$_CREATE_QUEUE, SJC\$_START_QUEUE function codes)

SJC\$_OPERATOR_REQUEST**SJC\$_NO_OPERATOR_REQUEST**

The `SJC$_OPERATOR_REQUEST` item code is an input value item code. It is meaningful only for output execution queues. The buffer must contain a text string. This item code specifies that, when a job begins execution, the execution queue is to be placed in the paused state and the specified text string is to be included in a message to the queue operator requesting service.

The `SJC$_NO_OPERATOR_REQUEST` item code is a Boolean item code. It specifies that no message is to be sent to the queue operator. It is the default.

(Valid for `SJC$_ALTER_JOB`, `SJC$_CREATE_JOB`, `SJC$_ENTER_FILE` function codes)

SJC\$_OWNER_UIC

The `SJC$_OWNER_UIC` item code is an input value item code. It specifies the owner UIC of a queue. The buffer must specify the longword UIC. By default, the owner UIC is [1,4].

(Valid for `SJC$_ALTER_QUEUE`, `SJC$_CREATE_QUEUE`, `SJC$_START_QUEUE` function codes)

SJC\$_PAGE_HEADER SJC\$_NO_PAGE_HEADER

The `SJC$_PAGE_HEADER` item code is a Boolean item code. It is meaningful only for output execution queues. It specifies that a page heading is to be printed on each page of output.

The `SJC$_NO_PAGE_HEADER` item code is a Boolean item code. It specifies that no page heading is to be printed. It is the default.

(Valid for `SJC$_ADD_FILE`, `SJC$_ALTER_JOB`, `SJC$_ENTER_FILE` function codes)

SJC\$_PAGE_SETUP_MODULES SJC\$_NO_PAGE_SETUP_MODULES

The `SJC$_PAGE_SETUP_MODULES` item code is an input value item code. The buffer must specify one or more text module names, with a comma separating each name. This item code specifies that these modules are to be extracted from the device control library and copied to the printer before each page is printed.

The `SJC$_NO_PAGE_SETUP_MODULES` item code is a Boolean item code. It specifies that no device control modules are to be copied. It is the default.

(Valid for `SJC$_DEFINE_FORM` function code)

SJC\$_PAGINATE SJC\$_NO_PAGINATE

The `SJC$_PAGINATE` item code is a Boolean item code. It is meaningful only for output execution queues and jobs submitted to output execution queues. It specifies that the symbiont should paginate the output by inserting a form feed whenever output reaches the bottom margin of the form. It is the default.

The `SJC$_NO_PAGINATE` item code is a Boolean item code. It specifies that the symbiont should not paginate the output.

(Valid for `SJC$_ADD_FILE`, `SJC$_ALTER_JOB`, `SJC$_ALTER_QUEUE`, `SJC$_CREATE_QUEUE`, `SJC$_ENTER_FILE`, `SJC$_START_QUEUE` function codes)

SJC\$_PARAMETER_1 through SJC\$_PARAMETER_8 SJC\$_NO_PARAMETERS

The SJC\$_PARAMETER_1 through SJC\$_PARAMETER_8 item codes are input value item codes; the last digit of the item code name is a number from 1 through 8. For each item code specified, the buffer must specify a string of no more than 255 characters. For batch jobs, the string becomes the value of the DCL symbol P1 through P8, respectively, within the outermost command procedure.

For print jobs, the system makes the string available to the symbiont, though the standard OpenVMS print symbiont does not use this information. By default, each of the eight parameters specifies a null string.

For function code SJC\$_ALTER_JOB, if any SJC\$_PARAMETER item is specified, the value of each unspecified item is the null string.

The SJC\$_NO_PARAMETERS item code is a Boolean item code. It specifies that none of the SJC\$_PARAMETER items are to be passed in the batch or print job. It is the default.

(Valid for SJC\$_ALTER_JOB, SJC\$_CREATE_JOB, SJC\$_ENTER_FILE function codes)

SJC\$_PASSALL **SJC\$_NO_PASSALL**

The SJC\$_PASSALL item code is a Boolean item code. It is meaningful only for jobs submitted to output execution queues. It specifies that the symbiont is to print the file in PASSALL mode.

The SJC\$_NO_PASSALL item code is a Boolean item code. It specifies that the symbiont is not to print the file in PASSALL mode. It is the default.

(Valid for SJC\$_ADD_FILE, SJC\$_ALTER_JOB, SJC\$_ENTER_FILE function codes)

SJC\$_PRINTER

The SJC\$_PRINTER item code is a Boolean item code. It is meaningful only for output queues. It specifies that the queue being created is a printer queue. The SJC\$_BATCH, SJC\$_PRINTER, SJC\$_SERVER, and SJC\$_TERMINAL item codes are mutually exclusive. If none of these item codes are specified, the default is SJC\$_PRINTER.

(Valid for SJC\$_CREATE_QUEUE function code)

SJC\$_PRIORITY

The SJC\$_PRIORITY item code is an input value item code. The buffer must specify a longword value in the range 0 through 255. This value specifies the scheduling priority of the job in a queue relative to the scheduling priority of other jobs in the same queue.

By default, the scheduling priority of the job is the value of the SYSGEN parameter DEFQUEPRI.

If you specify a value for SJC\$_PRIORITY that is greater than the SYSGEN parameter MAXQUEPRI and you do not have either ALTPRI or OPER privilege, the system uses the greater of the following two values: DEFQUEPRI or MAXQUEPRI. If you have either ALTPRI or OPER privilege, the system uses any value you specify for SJC\$_PRIORITY, even if it is included in the range between MAXQUEPRI + 1 and 255.

(Valid for SJC\$_ABORT_JOB, SJC\$_ALTER_JOB, SJC\$_CREATE_JOB, SJC\$_ENTER_FILE function codes)

SJC\$_PROCESSOR

SJC\$_NO_PROCESSOR

The SJC\$_PROCESSOR item code is an input value item code. The buffer must specify a valid OpenVMS RMS file name.

When specified for an output execution queue, SJC\$_PROCESSOR specifies that the symbiont image to be executed is SYS\$SYSTEM:name.EXE, where *name* is the RMS file name contained in the buffer.

When specified for a generic output queue, SJC\$_PROCESSOR specifies that the generic queue can place jobs only in server queues that are executing the symbiont image SYS\$SYSTEM:name.EXE, where *name* is the RMS file name contained in the buffer.

The SJC\$_NO_PROCESSOR item code is a Boolean item code. It specifies that the symbiont image to be executed is SYS\$SYSTEM:PRTSMB.EXE. It is the default.

(Valid for SJC\$_CREATE_QUEUE, SJC\$_START_QUEUE function codes)

SJC\$_PROTECTION

The SJC\$_PROTECTION item code is an input value item code. It specifies the protection of a queue.

The buffer must specify a longword in the format shown in the following diagram.

Value change enable												Protection value																			
World			Group			Owner			System			World			Group			Owner			System										
D	M	S	R	D	M	S	R	D	M	S	R	D	M	S	R	D	M	S	R	D	M	S	R	D	M	S	R	D	M	S	R
31	30	29	28	27	26	25	24	23	22	21	20	19	18	17	16	15	14	13	12	11	10	9	8	7	6	5	4	3	2	1	0

ZK-1724-GE

Bits 0 through 15 specify the protection value: the four types of access (read, submit, manage, delete) to be granted to the four categories of user (System, Owner, Group, World). Set bits deny access and clear bits allow access.

Bits 16 through 31 specify the protection enable mask: they identify which part of the protection value (bits 0 through 15) is to be applied to queue protection. If all bits are set in the enable mask, it means that all of the protection values are to be applied. A value other than -1 in the protection enable mask means that only those bits set will affect the corresponding bits in the protection value. When a bit in the protection enable mask is clear, the corresponding bit in the existing queue protection value is unchanged.

By default, the queue protection is (S:M,O:D,G:R,W:S).

Note that on all system types you can assign ACLs to queues using the \$SET_SECURITY system service.

(Valid for SJC\$_ALTER_QUEUE, SJC\$_CREATE_QUEUE, SJC\$_START_QUEUE function codes)

SJC\$_QUEUE

The SJC\$_QUEUE item code is an input value item code. It specifies the queue to which the operation is directed. The buffer must specify the name of the queue.

The string can contain uppercase or lowercase characters (lowercase are converted to uppercase), numeric characters, dollar signs (\$), and underscores (_). If the string is a logical name, SYS\$SNDJBC translates it iteratively until the equivalence string is found or the maximum number of translations

allowed by the system has been performed. The maximum length of the final character string is 31 characters; spaces, tabs, and null characters are ignored.

(The following function codes are valid for SJC\$_QUEUE item code:

SJC\$_ABORT_JOB
SJC\$_ALTER_JOB
SJC\$_ALTER_QUEUE
SJC\$_CREATE_JOB
SJC\$_CREATE_QUEUE
SJC\$_DELETE_JOB
SJC\$_DELETE_QUEUE
SJC\$_ENTER_FILE
SJC\$_START_QUEUE
SJC\$_SYNCHRONIZE_JOB)

SJC\$_QUEUE_DESCRIPTION
SJC\$_NO_QUEUE_DESCRIPTION

The SJC\$_QUEUE_DESCRIPTION item code is an input value item code. It provides operator-supplied information about the queue. The buffer must specify a string of no more than 255 characters.

The SJC\$_NO_QUEUE_DESCRIPTION item code is a Boolean item code. It specifies that no description is associated with the queue.

(Valid for SJC\$_ALTER_QUEUE, SJC\$_CREATE_QUEUE, SJC\$_START_QUEUE function codes)

SJC\$_QUEUE_DIRECTORY

The SJC\$_QUEUE_DIRECTORY item code is an input value item code. SJC\$_QUEUE_DIRECTORY specifies the directory location that contains the system queue and journal files for the queue manager. The queue file has a file type of QMAN\$QUEUES and contains queue definitions. The journal file has a file type of .QMAN\$JOURNAL and contains job and other information allowing the queue manager to return to its last known state should a system be stopped unexpectedly. These files must reside together in the same directory.

The default location of the queue and journal files is SYSS\$COMMON:[SYSEXE]. The optional use of SJC\$_QUEUE_DIRECTORY is for specifying an alternate location for the queue and journal files. The specification must include at least the device and directory name; wildcard characters are not allowed in the directory specification. The directory specified must be available to all nodes that can run the queue manager. If the directory specification is a concealed logical name, it must be defined identically on all nodes in the cluster.

The location of the queue and journal files is stored in the master file of the queue database. You do not have to respecify the directory location with subsequent use of SJC\$_START_QUEUE_MANAGER.

For more information, see the *VSI OpenVMS System Manager's Manual*.

(Valid for SJC\$_START_QUEUE_MANAGER function code)

SJC\$_QUEUE_MANAGER_NAME

The SJC\$_QUEUE_MANAGER_NAME item code is an input value item code. It uniquely identifies the queue manager process that manages some segment of the queues and jobs in the system. If it is not present, a default name of SYSS\$QUEUE_MANAGER is used.

The maximum length of the final character string is 31 characters. As with queue names, this can be a logical and will be resolved by the system. Once resolved, the name provided will serve as the file name for the queue and journal files, the process name, and the user name for the active process. Only the first 15 and 12 characters of the name are used for the process and user names, respectively.

(Valid for SJC\$_CREATE_QUEUE, SJC\$_DELETE_QUEUE_MANAGER, SJC\$_DISABLE_AUTOSTART, SJC\$_ENABLE_AUTOSTART, SJC\$_START_QUEUE_MANAGER, SJC\$_STOP_ALL_QUEUES_ON_NODE, SJC\$_STOP_QUEUE_MANAGER function codes)

SJC\$_QUEUE_MANAGER_NODES

The SJC\$_QUEUE_MANAGER_NODES item code is an input value item code. In an OpenVMS Cluster, SJC\$_QUEUE_MANAGER_NODES specifies a list of nodes that can run the queue manager. It also gives the explicit order of failover if the node running the queue manager exits the cluster. The specified node list is stored in the queue database.

The default value for the node list is an asterisk (*); it specifies that all nodes in the cluster are eligible to run the queue manager. The asterisk can also be specified as an element of the list. For example, a list can be specified as nodes A, B, C, *. If the node on which the queue manager is running leaves the cluster, the queue manager automatically fails over to any available node in the cluster; that is, if nodes A, B, and C are unavailable, then the queue manager can run on any other node. When establishing the node list, there is no validation of the individual nodes. If, for example, a node name is misspelled, there is no error status returned.

Anytime the SJC\$_START_QUEUE_MANAGER function code is used, the job controller checks the queue database to see if the node list is other than the default (*). If the node list is other than the default and the queue manager is running on a node other than the first available node of those specified, then the queue manager process is moved from its current node and restarted on the first available preferred node. When a current call includes the SJC\$_QUEUE_MANAGER_NODES item code, the job controller also updates the node list stored in the database. Despite this transition, queues on the running nodes are not stopped, and all requests to the queuing system complete as expected.

Note that because the specified node list is saved in the database, it is used every time the SJC\$_START_QUEUE_MANAGER function code is used, unless the node list has been changed by a more recent call to \$SNDJBC with the SJC\$_QUEUE_MANAGER_NODES item code.

For more information, see the *VSI OpenVMS System Manager's Manual*.

(Valid for SJC\$_START_QUEUE_MANAGER function code)

SJC\$_RAD (Alpha and Integrity servers)

Input value item code used to specify a RAD number on which to create a batch process. The item accepts a 32-bit integer value as input. The input is validated to be within the range of 0 to SYI\$_RAD_MAX_RADS.

RAD is supported on AlphaServer GS series systems and starting from OpenVMS Version 8.4, support is extended to NUMA capable Integrity servers.

(Valid for SJC\$_ALTER_JOB, SJC\$_ALTER_QUEUE, SJC\$_CREATE_JOB, SJC\$_CREATE_QUEUE, SJC\$_ENTER_FILE, SJC\$_START_QUEUE)

SJC\$_RECORD_BLOCKING SJC\$_NO_RECORD_BLOCKING

The `SJC$_RECORD_BLOCKING` item code is a Boolean item code. It is meaningful only for output execution queues. It specifies that the symbiont can merge the output records it sends to the output device into a single I/O request. For the standard OpenVMS print symbiont, record blocking can have a significant performance advantage over single-record mode. It is the default.

The `SJC$_NO_RECORD_BLOCKING` item code is a Boolean item code. It specifies that the symbiont must send each record in a separate I/O request to the output device.

(Valid for `SJC$_ALTER_QUEUE`, `SJC$_CREATE_QUEUE`, `SJC$_START_QUEUE` function codes)

SJC\$_RELATIVE_PAGE

The `SJC$_RELATIVE_PAGE` item code is an input value item code. It is meaningful only for output execution queues. The buffer must specify a signed longword integer. This item code specifies that printing should be resumed after spacing forward (if the buffer value is positive) or backward (if the buffer value is negative) the specified number of pages.

(Valid for `SJC$_START_QUEUE` function code)

SJC\$_REQUEUE

The `SJC$_REQUEUE` item code is a Boolean item code. It specifies that a job is to be requeued. By default, the job is deleted.

(Valid for `SJC$_ABORT_JOB` function code)

SJC\$_RESTART

SJC\$_NO_RESTART

The `SJC$_RESTART` item code is a Boolean item code. It specifies that a job can restart after a system failure or can be requeued during execution. It is the default for print jobs.

The `SJC$_NO_RESTART` item code is a Boolean item code. It specifies that a job cannot restart after a system failure or after a requeue operation. It is the default for batch jobs.

(Valid for `SJC$_ALTER_JOB`, `SJC$_CREATE_JOB`, `SJC$_ENTER_FILE` function codes)

SJC\$_RETAIN_ALL_JOBS

SJC\$_RETAIN_ERROR_JOBS

SJC\$_NO_RETAIN_JOBS

The `SJC$_RETAIN_ALL_JOBS` item code is a Boolean item code. It specifies that jobs are to be retained in the queue with a completion status after they have been executed.

The `SJC$_RETAIN_ERROR_JOBS` item code is a Boolean item code. It specifies that jobs are to be retained only if the job completed unsuccessfully (the job's completion status has the low bit clear).

The `SJC$_NO_RETAIN_JOBS` item code is a Boolean item code. It specifies that jobs are not to be retained in the queue after they have completed. It is the default.

(Valid for `SJC$_ALTER_QUEUE`, `SJC$_CREATE_QUEUE`, `SJC$_START_QUEUE` function codes)

SJC\$_SCSNODE_NAME

The `SJC$_SCSNODE_NAME` item code is an input value item code. It specifies the name of the node for which the command is to execute. The buffer must specify a 1- to 6-character string that matches the value of the `SYSGEN` parameter `SCSNODE` in effect on the target node.

When used with the function codes of `SJC$_STOP_ALL_QUEUES_ON_NODE`, `SJC$_DISABLE_AUTOSTART`, and `SJC$_ENABLE_AUTOSTART`, this item code requests a function on a node other than the node from which the `$$SNDJBC` request is sent.

`SJC$_SCSNODE_NAME` is meaningful only for execution queues in a cluster environment. By default, the queue executes on the node from which the queue is first started. For an output execution queue, you use the `SJC$_DEVICE_NAME` item code to specify the name of the device managed by the queue.

(Valid for `SJC$_CREATE_QUEUE`, `SJC$_DISABLE_AUTOSTART`, `SJC$_ENABLE_AUTOSTART`, `SJC$_START_QUEUE`, `SJC$_STOP_ALL_QUEUES_ON_NODE` function codes)

SJC\$_SEARCH_STRING

The `SJC$_SEARCH_STRING` item code is an input value item code. It is meaningful only for output execution queues. The buffer must specify a string of no more than 63 characters. This item code specifies that printing is to resume at the page containing the first occurrence of the specified string. The search for the string proceeds in the forward direction.

(Valid for `SJC$_START_QUEUE` function code)

SJC\$_SERVER

The `SJC$_SERVER` item code is a Boolean item code. It is meaningful only for output queues. It specifies that the queue being created is a server queue. The term server indicates that a user-modified or user-written symbiont process is controlling an output execution queue, or a generic queue has server execution queues as its targets.

The `SJC$_BATCH`, `SJC$_PRINTER`, `SJC$_SERVER`, and `SJC$_TERMINAL` item codes are mutually exclusive. If none of these item codes are specified, the default is `SJC$_PRINTER`.

(Valid for `SJC$_CREATE_QUEUE` function code)

SJC\$_SWAP SJC\$_NO_SWAP

The `SJC$_SWAP` item code is a Boolean item code. It is meaningful only for batch execution queues. It specifies that jobs initiated from a queue can be swapped. It is the default.

The `SJC$_NO_SWAP` item code is a Boolean item code. It specifies that jobs in this queue cannot be swapped.

(Valid for `SJC$_ALTER_QUEUE`, `SJC$_CREATE_QUEUE`, `SJC$_START_QUEUE` function codes)

SJC\$_TERMINAL SJC\$_NO_TERMINAL

The `SJC$_TERMINAL` item code is a Boolean item code. It is meaningful only for output queues. It specifies that the queue being created is a terminal queue.

The `SJC$_BATCH`, `SJC$_PRINTER`, `SJC$_SERVER`, and `SJC$_TERMINAL` item codes are mutually exclusive. If none of these item codes are specified, the default is `SJC$_PRINTER`.

The `SJC$_NO_TERMINAL` item code is a Boolean item code. It designates the queue type as printer rather than terminal. It is the default.

For the `SJC$_START_QUEUE` function code, `SJC$_TERMINAL` and `SJC$_NO_TERMINAL` are supported for compatibility with VAX/VMS Version 4.n, but might not be supported in the future. For

SJC\$_CREATE_QUEUE, SJC\$_NO_TERMINAL is supported for compatibility with VAX/VMS Version 4.n, and might not be supported in the future.

(Valid for SJC\$_CREATE_QUEUE, SJC\$_START_QUEUE function codes)

SJC\$_TOP_OF_FILE

The SJC\$_TOP_OF_FILE item code is a Boolean item code. It is meaningful only for output queues. It specifies that printing is to be resumed at the beginning of the file.

(Valid for SJC\$_START_QUEUE function code)

SJC\$_UIC

The SJC\$_UIC item code is an input value item code. This value specifies the 4-byte UIC of the user on behalf of whom the request is made. By default, the UIC is taken from the requesting process.

(Valid for SJC\$_CREATE_JOB, SJC\$_ENTER_FILE function codes)

SJC\$_USERNAME

The SJC\$_USERNAME item code is an input value item code. It specifies the user name of the user on behalf of whom the request is made. The buffer must specify a string from 1 to 12 characters. By default, the user name is taken from the requesting process.

You need CMKRNL privilege to use this item code.

(Valid for SJC\$_CREATE_JOB, SJC\$_ENTER_FILE function codes)

SJC\$_WSDEFAULT

SJC\$_NO_WSDEFAULT

The SJC\$_WSDEFAULT item code is an input value item code. It is meaningful only for batch jobs and execution queues. It specifies pagelets (on Alpha and Integrity server systems), the default working set size for batch jobs or jobs initiated from a batch queue, or the default working set size of a symbiont process connected to an output queue. A symbiont process can control several output queues; however, the default working set size of the symbiont process is established by the first queue to which it is connected. The buffer must contain a longword integer value in the range 1 through 65,535.

The SJC\$_NO_WSDEFAULT item code is a Boolean item code. It specifies that the system is to determine the working set default. It is the default.

For batch jobs, the default working set size, working set quota, and working set extent (maximum size) are included in each user record in the system user authorization file (UAF). You can specify values for these items for individual jobs or for all jobs in a given queue, or for both. Table 13 shows the action taken when you specify a value for SJC\$_WSDEFAULT.

Table 13. Working Set Decision Table

Value Specified for Job?	Value Specified for Queue?	Action Taken
No	No	Use UAF value
No	Yes	Use value for queue
Yes	Yes	Use lower of the two

Value Specified for Job?	Value Specified for Queue?	Action Taken
Yes	No	Compare specified value with UAF value; use lower

(Valid for SJC\$_ALTER_JOB, SJC\$_ALTER_QUEUE, SJC\$_CREATE_JOB, SJC\$_CREATE_QUEUE, SJC\$_ENTER_FILE, SJC\$_START_QUEUE function codes)

SJC\$_WSEXTENT **SJC\$_NO_WSEXTENT**

The SJC\$_WSEXTENT item code is an input value item code. It is meaningful only for batch jobs and execution queues. It specifies, pagelets (on Alpha and Integrity server systems), the working set extent for batch jobs or jobs initiated from a batch queue, or the working set extent of a symbiont process connected to an output queue. A symbiont process can control several output queues; however, the working set extent of the symbiont process is established by the first queue to which it is connected. The buffer must contain a longword integer value in the range 1 through 65,535.

The SJC\$_NO_WSEXTENT item code is a Boolean item code. It specifies that the system determine the working set extent. It is the default.

For information about the action taken when you specify a value for SJC\$_WSEXTENT for a batch job or batch queue, see the description of the SJC\$_WSDEFAULT item code and to 13

(Valid for SJC\$_ALTER_JOB, SJC\$_ALTER_QUEUE, SJC\$_CREATE_JOB, SJC\$_CREATE_QUEUE, SJC\$_ENTER_FILE, SJC\$_START_QUEUE function codes)

SJC\$_WSQUOTA **SJC\$_NO_WSQUOTA**

The SJC\$_WSQUOTA item code is an input value item code. It is meaningful only for batch jobs and execution queues. It specifies, pagelets (on Alpha and Integrity server systems), the working set quota for batch jobs or default WSQUOTA for jobs initiated from a batch queue, or the working set quota of a symbiont process connected to an output queue. A symbiont process can control several output queues; however, the working set quota of the symbiont process is established by the first queue to which it is connected. The buffer must contain a longword integer value in the range 1 through 65,535.

The SJC\$_NO_WSQUOTA item code is a Boolean item code. It specifies that the system is to determine the working set quota. It is the default.

For information about the action taken when you specify a value for SJC\$_WSQUOTA for a batch job or batch queue, see the description of the SJC\$_WSDEFAULT item code and to 13

(Valid for SJC\$_ALTER_JOB, SJC\$_ALTER_QUEUE, SJC\$_CREATE_JOB, SJC\$_CREATE_QUEUE, SJC\$_ENTER_FILE, SJC\$_START_QUEUE function codes)

Description

The Send to Job Controller service creates, stops, and manages queues and the batch and print jobs in those queues. The \$\$NDJBC and \$GETQUI (Get Queue Information) services together provide the user interface to the queue manager and job controller processes. See the description of the \$GETQUI service for a discussion of queues and jobs initiated from those queues.

\$\$NDJBC completes asynchronously; that is, it returns to the caller after queuing the request, without waiting for the operation to complete.

To synchronize the completion of most operations, you use the Send to Job Controller and Wait (\$\$SNDJBCW) service. The \$\$SNDJBCW service is identical to \$\$SNDJBC in every way except that \$\$SNDJBCW returns to the caller after the operation completes.

Types of Queues

The VMS batch and print queuing system supports several types of queues, which aid in the processing of batch and print jobs. The different types of queues can be divided into three major categories according to the way the system processes the jobs assigned to the queue. The three types of queues are execution, generic, and logical. Execution queues schedule jobs for execution; generic and logical queues transfer jobs to execution queues. Within these major classifications, queue type is further defined by the kinds of job the queues can accept for processing. Some types of execution and generic queues accept batch jobs; other types accept print jobs. Logical queues are restricted to print jobs.

You create a queue by making a call to \$\$SNDJBC specifying the SJC\$_CREATE_QUEUE function code. Item codes that you optionally specify in the call determine the type of queue you create. The following list describes the various types of execution, generic, and logical queues and indicates which item codes you need to specify to create them:

- **Execution queue.** An execution queue schedules jobs for processing. In an OpenVMS Cluster environment, jobs are processed on the node that manages the execution queue. There are two types of execution queues:
 - **Batch execution queue.** A batch execution queue can schedule only batch jobs for execution. A batch job executes as a detached process that sequentially runs one or more command procedures; you define the list of command procedures as part of the initial job description. You create a batch execution queue by specifying the SJC\$_BATCH item code in the call to the \$\$SNDJBC service.
 - **Output execution queue.** An output execution queue schedules print jobs for processing by an independent symbiont process associated with the queue. The job controller sends the symbiont a list of files to process; you define this list of files as part of the initial job description. As the symbiont processes each file, it produces output for the device, such as a printer or terminal, that it controls.

The standard print symbiont image provided by the operating system is designed to print files on hardcopy devices. User-modified or user-written symbionts also can be designed for this or any other file processing activity managed by the batch and print queuing system. The symbiont image that executes jobs from an output queue is specified by the SJC\$_PROCESSOR item code. If you omit this item code, the standard print symbiont image, PRTSMB, is associated with the queue.

There are three types of output execution queue:

- a. **Printer execution queue.** This type of queue typically uses the standard print symbiont to direct output to a line printer. You can specify a user-provided symbiont in the SJC\$_PROCESSOR item code. You create a printer execution queue by specifying the SJC\$_PRINTER item code when you create the output execution queue. A printer execution queue is the default type of output execution queue.
- b. **Terminal execution queue.** This type of queue typically uses the standard print symbiont to direct output to a terminal printer. You can specify a user-provided symbiont in the SJC\$_PROCESSOR item code. You create a terminal execution queue by specifying the SJC\$_TERMINAL item code when you create the output execution queue.

- c. **Server execution queue.** This type of queue uses the user-modified or user-written symbiont you specify in the SJC\$_PROCESSOR item code to process the files that belong to jobs in the queue. You create a server execution queue by specifying the SJC\$_SERVER item code when you create the output execution queue.

When you create an output execution queue, you can initially mark it as either a printer, terminal, or server execution queue. However, when the queue is started, the symbiont process associated with the queue can change the queue type from the type designated at its creation to a printer, terminal, or server execution queue, as follows:

- a. When an output execution queue associated with the standard print symbiont is started, the symbiont determines whether it is controlling a printer or terminal. It communicates this information to the job controller. If necessary, the job controller then changes the type designation of the output execution queue.
 - b. When an output execution queue associated with a user-modified or user-written symbiont is started, the symbiont has the option of identifying the queue to the job controller as a server queue. If the user-written or user-modified symbiont does not notify the job controller that it wants to change the queue type designation, the output execution queue retains the queue type designation it received when it was created.
- **Generic queue.** A generic queue holds a job until an appropriate execution queue becomes available to initiate the job; the job controller then requeues the job to the available execution queue. In a cluster environment, a generic queue can direct jobs to execution queues that are located on other nodes in the cluster.

You create a generic queue by specifying the SJC\$_GENERIC_QUEUE item code in the call to the \$SNDJBC service. You designate each execution queue to which the generic queue can direct jobs by specifying the SJC\$_GENERIC_TARGET item code. Because a generic queue can direct jobs to more than one execution queue, you can specify the SJC\$_GENERIC_TARGET item code up to 124 times in a single call to \$SNDJBC to define a complete set of execution queues for any generic queue. If you do not specify the SJC\$_GENERIC_TARGET item code, the generic queue directs jobs to any execution queue that is the same type of queue as the generic queue; that is, a generic batch queue will direct a job to any available batch execution queue, and so on. There is one exception: a generic queue will not direct work to any execution queue that was created in a call to \$SNDJBC that specified the SJC\$_NO_GENERIC_SELECTION item code.

There are two types of generic queue:

- **Generic batch queue.** A generic batch queue can direct jobs only to batch execution queues. You create a generic batch queue by specifying both the SJC\$_GENERIC_QUEUE and SJC\$_BATCH item codes in the call to the \$SNDJBC service.
- **Generic output queue.** A generic output queue can direct jobs to any of the three types of output execution queue: printer, terminal, or server. Creating a generic output queue that directs jobs to any combination of the three types of output execution queue is possible. Typically, however, when you create a generic output queue, you specify a list of type-specific target queues. This way, the generic output queue directs jobs to a single type of output execution queue. Thus, you can control whether the jobs submitted to the generic output execution queue are output on a line printer or a terminal printer or are sent to a server symbiont for processing. You create a generic output queue by specifying the SJC\$_GENERIC_QUEUE item code in the call to the \$SNDJBC service.

- **Logical queue.** A logical queue performs the same function as a generic output queue, except that a logical queue can direct jobs to only a single printer, terminal, or server execution queue. A logical queue is only an output queue that has been assigned to transfer its jobs to one execution queue.

To change an output queue into a logical queue, you make a call to the `$$SNDJBC` service while the output queue is in a stopped state. The call must specify the `SJC$_ASSIGN_QUEUE` function code and the `SJC$_DESTINATION_QUEUE` item code. You use the `SJC$_DESTINATION_QUEUE` item code to specify the execution queue to which the logical queue should direct jobs. When the logical queue is started, it automatically requeues its jobs to the specified execution queue as that execution queue becomes available. You can change a logical queue back to its original output queue definition by specifying the `SJC$_DEASSIGN_QUEUE` function code in a subsequent call to the `$$SNDJBC` service.

Queue Protection

This section describes UIC-based protection checking that is performed by the `$$SNDJBC` service to control access to queues.

As an alternative to this form of protection checking, you can associate ACLs with queues using the appropriate security services. See the `$GET_SECURITY` and `$SET_SECURITY` system services for more information.

There are two aspects to UIC-based queue protection:

- When you create a queue, you assign it a UIC by using the `SJC$_OWNER_UIC` item code. If you do not specify this item code, the queue is given the default UIC [1,4].
- You can assign a queue a protection mask by specifying the `SJC$_PROTECTION` item code. This protection mask specifies read, submit, manage, and delete access for the four categories of user: Owner, Group, World, and System.

In addition, certain queue operations require the caller of `$$SNDJBC` to have certain privileges. The function codes that require privileges are listed in the Privileges and Restrictions section.

When a job is submitted to a queue, it is assigned a UIC that is the same as the UIC of the process submitting the job, unless the `SJC$_UIC` item code is specified to supply a different UIC.

For each requested operation, the `$$SNDJBC` service checks the UIC and privileges of the requesting process against the UIC of the queue, protection specified for the queue, and the privileges, if any, required for the operation. This checking is performed in a way similar to the way that the file system checks access to a file by comparing the owner UIC and protection of the file with the UIC and privileges of the requester.

Operations that apply to jobs are checked against read and delete protection specified for the queue in which the job is entered and the owner UIC of the job. In general, read access to a job allows you to determine that the job exists; delete access to a job allows you to affect the job.

Operations that apply to queues are checked against the submit and manage protection specified for the queue and the owner UIC of the queue. In general, submit access to a queue allows you to submit jobs to the queue; manage access to a queue allows you to act as an operator for the queue, including the ability to affect jobs in the queue, to affect accounting, and to alter queues. `OPER` privilege grants manage access to all queues.

Privileges and Restrictions

To specify the following function codes, the caller must have both `OPER` and `SYSNAM` privilege:

SJC\$_DELETE_QUEUE_MANAGER
SJC\$_START_QUEUE_MANAGER
SJC\$_STOP_QUEUE_MANAGER

To specify the following function codes, the caller must have OPER privilege:

SJC\$_CREATE_QUEUE
SJC\$_DEFINE_CHARACTERISTIC
SJC\$_DEFINE_FORM
SJC\$_DELETE_CHARACTERISTIC
SJC\$_DELETE_FORM
SJC\$_DELETE_QUEUE
SJC\$_START_ACCOUNTING
SJC\$_STOP_ACCOUNTING

To specify the following function code, the caller can have OPER privilege or manage access:

SJC\$_DELETE_QUEUE

To specify the following function code, the caller must have OPER privilege, execute access to the queue containing the specified job, or read access to the specified job:

SJC\$_SYNCHRONIZE_JOB

To specify the following function codes, the caller must have OPER privilege, manage access to the specified queue, or submit access to the specified queue:

SJC\$_ADD_FILE
SJC\$_CLOSE_DELETE
SJC\$_CLOSE_JOB
SJC\$_CREATE_JOB
SJC\$_ENTER_FILE

To specify the following function codes, the caller must have OPER privilege or manage access to the specified queue or queues:

SJC\$_ALTER_QUEUE
SJC\$_ASSIGN_QUEUE
SJC\$_DEASSIGN_QUEUE
SJC\$_DISABLE_AUTOSTART
SJC\$_ENABLE_AUTOSTART
SJC\$_MERGE_QUEUE
SJC\$_PAUSE_QUEUE
SJC\$_RESET_QUEUE
SJC\$_START_QUEUE
SJC\$_STOP_ALL_QUEUES_ON_NODE
SJC\$_STOP_QUEUE

To specify the following function codes, the caller must have OPER privilege, manage access to the queue containing the specified job, or delete access to the specified job:

SJC\$_ABORT_JOB
SJC\$_ALTER_JOB
SJC\$_DELETE_JOB

To specify the following function codes, no privilege is required:

SJC\$_BATCH_CHECKPOINT
SJC\$_WRITE_ACCOUNTING

To specify a scheduling priority (using the SJC\$_PRIORITY item code) higher than the value of the system parameter MAXQUEPRI, the caller needs OPER or ALTPRI privilege.

To specify the following item codes, the caller must have OPER privilege:

SJC\$_OWNER_UIC
SJC\$_PROTECTION

To specify the following item codes, the caller must have CMKRNL privilege:

SJC\$_ACCOUNT_NAME
SJC\$_UIC
SJC\$_USERNAME

Required Quota

To specify the *astadr* argument, the process must have sufficient ASTLM quota.

Related Services

\$ALLOC, \$ASSIGN, \$BRKTHRU, \$BRKTHRUW, \$CANCEL, \$CREMBX, \$DALLOC, \$DASSGN, \$DELMBX, \$DEVICE_SCAN, \$DISMOU, \$GETDVI, \$GETDVIW, \$GETMSG, \$GETQUI, \$GETQUIW, \$INIT_VOL, \$MOUNT, \$PUTMSG, \$QIO, \$QIOW, \$SNDERR, \$SNDJBCW, \$SNDOPR, \$TRNLNM

Condition Values Returned

SS\$_NORMAL

The service completed successfully.

SS\$_ACCVIO

The item list or input buffer cannot be read by the caller; or the return length buffer, output buffer, or status block cannot be written by the caller.

SS\$_BADPARAM

The function code is invalid; the item descriptor contains an invalid buffer length value; a buffer descriptor has an invalid length; or the reserved parameter has a nonzero value.

SS\$_DEVOFFLINE

The job controller process is not running.

SS\$_EXASTLM

You specified the *astadr* argument, and the process has exceeded its ASTLM quota.

SS\$_ILLEFC

The *efn* argument specifies an illegal event flag number.

SS\$_INSFMEM

Insufficient space exists for completing the request.

SS\$_IVLOGNAM

Queue form or characteristic name is not a valid logical name.

SS\$_MBFULL

The job controller mailbox is full.

SS\$_MBTOOSML

The mailbox message is too large for the job controller mailbox.

SS\$_SHELVED

The job controller attempted to access a shelved file. The service does not automatically unshelve files.

SS\$_UNASEFC

The *efn* argument specifies an unassociated event flag cluster.

Condition Values Returned in the I/O Status Block

JBC\$_NORMAL

The service completed successfully.

JBC\$_AUTONOTSTART

The queue is autostart active, but not started. You have tried to start an autostart queue when none of its available nodes has autostart enabled.

JBC\$_BUFTOOSMALL

The request could not be completely satisfied due to limited buffer size. The amount of information retrieved in response to the query exceeds the amount of data the queue manager can return in response to a single request.

JBC\$_DELACCESS

The file protection of the specified file, which was entered with the delete option, does not allow delete access to the caller.

JBC\$_DUPCHARNAME

The command specified a duplicate characteristic name. Each characteristic must have a unique name.

JBC\$_DUPCHARNUM

The command specified a duplicate characteristic number. Each characteristic must have a unique number.

JBC\$_DUPFORM

The specified form number is invalid because it is already defined; each form must have a unique form number.

JBC\$_DUPFORMNAME

The command specified a duplicate form name. Each form must have a unique name.

JBC\$_EMPTYJOB

The open job cannot be closed because it contains no files.

JBC\$_EXECUTING

The parameters of the specified job cannot be modified because the job is currently executing.

JBC\$_INCDSTQUE

The type of the specified destination queue is inconsistent with the requested operation.

JBC\$_INCFORMPAR

The specified length, width, and margin parameters are inconsistent; the value of the difference between the top and bottom margin parameters must be less than the form length, and the difference between the left and right margin parameters must be less than the line width.

JBC\$_INCOMPLETE

The requested queue management operation cannot be executed because a previously requested queue management operation has not yet completed.

JBC\$_INCQUETYP

The type of the specified queue is inconsistent with the requested operation.

JBC\$_INTERNALERROR

An internal error caused loss of process status. A system error prevented the queue manager from obtaining the completion status of a process.

JBC\$_INVCHANAM

A specified characteristic name is not syntactically valid.

JBC\$_INVDSTQUE

The destination queue name is not syntactically valid.

JBC\$_INVFORNAM

The form name is not syntactically valid.

JBC\$_INVFUNCOD

The specified function code is invalid.

JBC\$_INVITMCOD

The item list contains an invalid item code.

JBC\$_INVPARLEN

The length of a specified string is outside the valid range for that item code.

JBC\$_INVPARVAL

A parameter value specified for an item code is outside the valid range for that item code.

JBC\$_INVQUENAM

The queue name is not syntactically valid.

JBC\$_ITMREMOVED

The meaningless items were removed from the request. One or more item codes not meaningful to this command were specified. The command is processed and the meaningless items are ignored.

JBC\$_JOBNOTEXEC

The specified job is not executing.

JBC\$_JOBQUEDIS

The request cannot be executed because the system job queue manager has not been started.

JBC\$_JOBQUEENA

The system job queue manager cannot be started because it is already running.

JBC\$_MISREQPAR

An item code that is required for the specified function code has not been specified.

JBC\$_NOAUTOSTART

The node does not have the autostart feature enabled.

JBC\$_NODSTQUE

The specified destination queue does not exist.

JBC\$_NOOPENJOB

The requesting process did not open a job with the SJC\$_CREATE_JOB function.

JBC\$_NOPRIV

The queue protection denies access to the queue for the specified operation.

JBC\$_NOQUESPACE

The system job queue file was full and could not be extended.

JBC\$_NORESTART

The specified job cannot be requeued because it was not defined as restartable.

JBC\$_NOSUCHCHAR

The specified characteristic does not exist.

JBC\$_NOSUCHENT

There is no job with the specified entry number.

JBC\$_NOSUCHFORM

The specified form does not exist.

JBC\$_NOSUCHJOB

The specified job does not exist.

JBC\$_NOSUCHMGR

The specified queue manager does not exist.

JBC\$_NOSUCHNODE

The specified node does not exist.

JBC\$_NOSUCHQUE

The specified queue does not exist.

JBC\$_NOTALLREQUE

Not all jobs in the source queue could be requeued to the target queue. Some of the jobs specified were not suitable for execution on the specified target queue.

JBC\$_NOTASSIGN

The specified queue cannot be deassigned because it is not assigned.

JBC\$_NOTMEANINGFUL

The specified item code is no longer meaningful.

JBC\$_NOTSUPPORTED

The specified item code or function code is not supported.

JBC\$_PRIOSMALL

The scheduling priority has a smaller value than requested. A user without ALTPRI or OPER privilege specified a value for a job's priority that exceeded the queue's maximum priority for

nonprivileged jobs. The job is entered in the queue, but its scheduling priority is lower than the value requested by the user.

JBC\$_QMANNOTSTARTED

The queue manager could not be started.

JBC\$_QUEDISABLED

The disabled queue cannot be modified, nor can jobs be submitted to it.

JBC\$_QUENOTMOD

The modifications were not made because the queue was not stopped.

JBC\$_QUENOTSTOP

The specified queue cannot be deleted because it is not in a stopped state.

JBC\$_REFERENCED

The specified queue cannot be deleted because of existing references by other queues or jobs.

JBC\$_STARTED

The specified queue cannot be started because it is already running.

JBC\$_STKNOTCHANGE

The stock associated with a form cannot be changed.

JBC\$_TOOMUCHINFO

The size of the data in request exceeds system constraints. The amount of data specified for a record within the queue manager's database is too large.

When you use the SJC\$_SYNCHRONIZE_JOB function code, the return value is the exit status of the specified job.

When you start a symbiont queue with the SJC\$_START_QUEUE function code or the SJC\$_CREATE_QUEUE function code with the SJC\$_CREATE_START item code, any error encountered by the symbiont process will be returned in the IOSB.

Examples

```
$ vfyold = f$verify(1)
$ create sys$scratch:accounting.c
#include <efndef.h>
#include <lib$routines.h>
#include <sjcdef.h>
#include <ssdef.h>
#include <starlet.h>
#include <stddef.h>
#include <stsdef.h>
struct ItemList3
{
    short int ItemLength;
```

```

    short int ItemCode;
    void *ItemBuffer;
    void *ItemRetLen;
};

#define MAXITMLST 3
main()
{
    int i;
    struct ItemList3 JbcIL[MAXITMLST];
    unsigned short int IOSB[4];
    int RetStat, JbcMask, JbcFunc;

    /* To start accounting: */
    JbcFunc = SJC$_START_ACCOUNTING;

    /* Specify image and interactive */
    JbcMask = SJC$_M_ACCT_IMAGE | SJC$_M_ACCT_INTERACTIVE;

    i = 0;
    JbcIL[i].ItemLength      = sizeof( JbcMask );
    JbcIL[i].ItemCode        = SJC$_ACCOUNTING_TYPES;
    JbcIL[i].ItemBuffer      = (void *) &JbcMask;
    JbcIL[i++].ItemRetLen    = NULL;
    JbcIL[i].ItemLength      = 0;
    JbcIL[i].ItemCode        = 0;
    JbcIL[i].ItemBuffer      = NULL;
    JbcIL[i++].ItemRetLen    = NULL;

    RetStat = sys$sndjbcw(EFN$_C_ENF, JbcFunc, 0, JbcIL, IOSB, 0, 0);
    if (!$VMS_STATUS_SUCCESS( RetStat ))
        lib$signal( RetStat );
    if (!$VMS_STATUS_SUCCESS( IOSB[0] ))
        lib$signal( IOSB[0] );

    return SS$_NORMAL;
}
$ cc/decc/prefix=all sys$scratch:accounting.c/object=sys$scratch:
$ link/executable=sys$scratch:accounting.exe sys$scratch:accounting
$ show accounting
$ prvoid = f$setprv("OPER")
$ run sys$scratch:accounting
$ show accounting
$ priv = f$setprv(prvoid)
$ vfyold = f$verify(vfyold)
$ exit

```

This C program demonstrates an \$SNDJBCW call.

```

! Declare system service related symbols
INTEGER*4      SYS$SNDJBCW,
2              STATUS
INCLUDE        '($JCDEF)'

! Define item list structure
STRUCTURE      /ITMLST/
UNION
    MAP

```

```

        INTEGER*2 BUFLen, ITMCOD
        INTEGER*4 BUFADR, RETADR
    END MAP
    MAP
        INTEGER*4 END_LIST
    END MAP
END UNION
END STRUCTURE

! Define I/O status block structure
STRUCTURE      /IOSBLK/
INTEGER*4      STS, ZEROED
END STRUCTURE

! Declare $$SNDJBCW item list and I/O status block
RECORD /ITMLST/ SUBMIT_LIST(6)
RECORD /IOSBLK/ IOSB
! Declare variables used in $$SNDJBCW item list
CHARACTER*9    QUEUE                /'SYS$BATCH'/
CHARACTER*23   FILE_SPECIFICATION   /'$DISK1:[COMMON]TEST.COM'/
CHARACTER*12   USERNAME             /'PROJ3036  '/
INTEGER*4      ENTRY_NUMBER

! Initialize item list for the enter file operation
SUBMIT_LIST(1).BUFLen = 9
SUBMIT_LIST(1).ITMCOD = SJC$_QUEUE
SUBMIT_LIST(1).BUFADR = %LOC(QUEUE)
SUBMIT_LIST(1).RETADR = 0
SUBMIT_LIST(2).BUFLen = 23
SUBMIT_LIST(2).ITMCOD = SJC$_FILE_SPECIFICATION
SUBMIT_LIST(2).BUFADR = %LOC(FILE_SPECIFICATION)
SUBMIT_LIST(2).RETADR = 0
SUBMIT_LIST(3).BUFLen = 12
SUBMIT_LIST(3).ITMCOD = SJC$_USERNAME
SUBMIT_LIST(3).BUFADR = %LOC(USERNAME)
SUBMIT_LIST(3).RETADR = 0
SUBMIT_LIST(4).BUFLen = 0
SUBMIT_LIST(4).ITMCOD = SJC$_NO_LOG_SPECIFICATION
SUBMIT_LIST(4).BUFADR = 0
SUBMIT_LIST(4).RETADR = 0
SUBMIT_LIST(5).BUFLen = 4
SUBMIT_LIST(5).ITMCOD = SJC$_ENTRY_NUMBER_OUTPUT
SUBMIT_LIST(5).BUFADR = %LOC(ENTRY_NUMBER)
SUBMIT_LIST(5).RETADR = 0
SUBMIT_LIST(6).END_LIST = 0

! Call $$SNDJBCW service to submit the batch job
STATUS = SYS$$SNDJBCW (,
2          %VAL(SJC$_ENTER_FILE),,
2          SUBMIT_LIST,
2          IOSB,,)
IF (STATUS) STATUS = IOSB.STS
IF (.NOT. STATUS) CALL LIB$SIGNAL (%VAL(STATUS))
END

```

This Fortran program demonstrates the use of the \$\$SNDJBCW service to submit a batch job that is to execute on behalf of another user. No log file is produced for the batch job. This program saves the job's entry number. You need CMKRNL privilege to run this program.

\$SNDJBCW

Send to Job Controller and Wait — The Send to Job Controller and Wait and \$GETQUI services together provide the user interface to the Job Controller (JBC) facility. The \$SNDJBCW service allows you to create, stop, and manage queues and the jobs in those queues. Queues can be generic, batch, execution, or output queues. Jobs can be batch or print jobs.

Format

```
SYSSNDJBCW
    [efn] ,func [,nullarg] [,itmlst] [,iosb] [,astadr] [,astprm]
```

C Prototype

```
int sys$sndjbcw
    (unsigned int efn, unsigned short int func, unsigned int nullarg,
     void *itmlst, struct _iosb *iosb, void (*astadr)(__unknown_params),
     int astprm);
```

Description

The \$SNDJBCW service queues a request to the job controller. For most operations, \$SNDJBCW completes synchronously; that is, it returns to the caller after the operation completes. However, if the requested operation is a pause queue, stop queue, or abort job operation, \$SNDJBCW returns to the caller after queuing the request. There is no way to synchronize completion of these operations. Also, \$SNDJBCW does not wait for a job to complete before it returns to the caller. To synchronize completion of a job, the caller must specify the SJC\$_SYNCHRONIZE_JOB function code.

The \$SNDJBCW service is identical to the Send to Job Controller (\$SNDJBC) service except that \$SNDJBC completes asynchronously; the \$SNDJBC service returns to the caller immediately after queuing the request, without waiting for the operation to complete.

For additional information about \$SNDJBCW, refer to the documentation of \$SNDJBC.

The \$SNDJBC and \$SNDJBCW services supersede the Send Message to Symbiont Manager (\$SNDSMB) and Send Message to Accounting Manager (\$SNDACC) services. You should write new programs using \$SNDJBC or \$SNDJBCW, instead of \$SNDSMB or \$SNDACC. You should convert old programs using \$SNDSMB or \$SNDACC to use \$SNDJBC or \$SNDJBCW, as convenient.

\$SNDOPR

Send Message to Operator — Performs the following functions: 1) Sends a user request to operator terminals 2) Sends a user cancellation request to operator terminals 3) Sends an operator reply to a user terminal 4) Enables an operator terminal 5) Displays the status of an operator terminal 6) Initializes the operator log file

Format

```
SYSSNDOPR msgbuf , [chan]
```

C Prototype

```
int sys$sndopr (void *msgbuf, unsigned short int chan);
```

Arguments

msgbuf

OpenVMS usage: char_string
 type: character-coded text string
 access: read only
 mechanism: by descriptor–fixed-length string descriptor

User buffer specifying the operation to be performed and the information needed to perform that operation. The *msgbuf* argument is the address of a character string descriptor pointing to the buffer.

The format and contents of the buffer vary with the requested operation; however, the first byte in any buffer is the request code, which specifies the operation to be performed. The \$OPCMSG macro defines the symbolic names for these request codes. The following table shows each operation that \$SENDOPR performs and the request code that specifies that operation.

Request Code	Corresponding Operation
OPC\$_RQ_CANCEL	Sends a user cancellation request to specified operator terminals. You use this request code to notify one or more operators that a previous request is to be canceled. To specify OPC\$_RQ_CANCEL, you must also specify the <i>chan</i> argument.
OPC\$_RQ_LOGI	Initializes the operator log file.
OPC\$_RQ_REPLY	Sends an operator reply to a user who has made a request. Operators use this request code to report the status of a user request. The format of the message buffer for this request is the format of the reply found in the user's mailbox after the call to \$SENDOPR completes. All functions of \$SENDOPR that deliver a reply to a mailbox do so in the format described for this request code.
OPC\$_RQ_RQST	Sends a user request to operator terminals. This request code is used to make an operator request. If you specify a reply to the request (by using the <i>chan</i> argument), the operator request is kept active until the operator responds.
OPC\$_RQ_STATUS	Reports the status of an operator terminal. Operators use this request to display the operator classes for which the specified terminal is enabled and a list of outstanding requests.
OPC\$_RQ_TERME	Enables an operator terminal. You use this request to enable a specified terminal to receive operator messages.

The following diagrams depict the message buffer for each of these request codes. Each field within a diagram has a symbolic name, which serves to identify the field; in other words, these names specify offsets into the message buffer. The list following each diagram shows each field name and what its contents can or should be. The \$OPCDEF macro defines the field names, as well as any other symbolic name that can be specified as the contents of a field.

Message Buffer Format for OPC\$_RQ_RQST

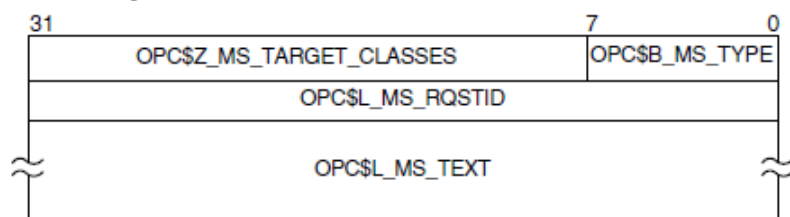

ZK-1725-GE

OPC\$B_MS_TYPE	This 1-byte field contains the request code OPC\$_RQ_RQST.																				
OPC\$B_MS_TARGET_CLASSES	This 3-byte field contains a 24-bit bit vector that specifies which operator terminal types are to receive the request. The \$OPCDEF macro defines symbolic names for the operator terminal types. You construct the bit vector by specifying the desired symbolic names in a logical OR operation. Following is the symbolic name of each operator terminal type: <table border="1" data-bbox="603 801 1447 1303"> <tr> <td>OPC\$M_NM_CARDS</td> <td>Card device operator</td> </tr> <tr> <td>OPC\$M_NM_CENTRL</td> <td>Central operator</td> </tr> <tr> <td>OPC\$M_NM_CLUSTER</td> <td>OpenVMS Cluster operator</td> </tr> <tr> <td>OPC\$M_NM_DEVICE</td> <td>Device status information</td> </tr> <tr> <td>OPC\$M_NM_DISKS</td> <td>Disk operator</td> </tr> <tr> <td>OPC\$M_NM_NETWORK</td> <td>Network operator</td> </tr> <tr> <td>OPC\$M_NM_TAPES</td> <td>Tape operator</td> </tr> <tr> <td>OPC\$M_NM_PRINT</td> <td>Printer operator</td> </tr> <tr> <td>OPC\$M_NM_SECURITY</td> <td>Security operator</td> </tr> <tr> <td>OPC\$M_NM_OPER1 through OPC\$M_NM_OPER12</td> <td>System-manager-defined operator functions</td> </tr> </table>	OPC\$M_NM_CARDS	Card device operator	OPC\$M_NM_CENTRL	Central operator	OPC\$M_NM_CLUSTER	OpenVMS Cluster operator	OPC\$M_NM_DEVICE	Device status information	OPC\$M_NM_DISKS	Disk operator	OPC\$M_NM_NETWORK	Network operator	OPC\$M_NM_TAPES	Tape operator	OPC\$M_NM_PRINT	Printer operator	OPC\$M_NM_SECURITY	Security operator	OPC\$M_NM_OPER1 through OPC\$M_NM_OPER12	System-manager-defined operator functions
OPC\$M_NM_CARDS	Card device operator																				
OPC\$M_NM_CENTRL	Central operator																				
OPC\$M_NM_CLUSTER	OpenVMS Cluster operator																				
OPC\$M_NM_DEVICE	Device status information																				
OPC\$M_NM_DISKS	Disk operator																				
OPC\$M_NM_NETWORK	Network operator																				
OPC\$M_NM_TAPES	Tape operator																				
OPC\$M_NM_PRINT	Printer operator																				
OPC\$M_NM_SECURITY	Security operator																				
OPC\$M_NM_OPER1 through OPC\$M_NM_OPER12	System-manager-defined operator functions																				
OPC\$L_MS_RQSTID	This longword field contains a user-supplied longword message code.																				
OPC\$L_MS_TEXT	This variable-length field contains an ASCII string specifying text to be sent to the specified operator terminals. \$SENDOPR uses the buffer size of the device to which the message is being sent.																				

Message Buffer Format for OPC\$_RQ_CANCEL

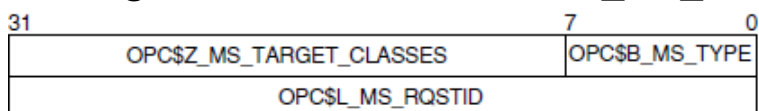

ZK-1726-GE

OPC\$B_MS_TYPE	This 1-byte field contains the request code OPC\$_RQ_CANCEL.		
OPC\$B_MS_TARGET_CLASSES	This 3-byte field contains a 24-bit bit vector that specifies which operator terminal types are to receive the cancellation request. The \$OPCDEF macro defines symbolic names for the operator terminal types. You construct the bit vector by specifying the desired symbolic names in a logical OR operation. Following is the symbolic name of each operator terminal type: <table border="1" data-bbox="603 2002 1447 2040"> <tr> <td>OPC\$M_NM_CARDS</td> <td>Card device operator</td> </tr> </table>	OPC\$M_NM_CARDS	Card device operator
OPC\$M_NM_CARDS	Card device operator		

	OPC\$M_NM_CENTRL	Central operator
	OPC\$M_NM_SECURITY	Security operator
	OPC\$M_NM_CLUSTER	OpenVMS Cluster operator
	OPC\$M_NM_DEVICE	Device status information
	OPC\$M_NM_DISKS	Disk operator
	OPC\$M_NM_NETWORK	Network operator
	OPC\$M_NM_TAPES	Tape operator
	OPC\$M_NM_PRINT	Printer operator
	OPC\$M_NM_OPER1 through OPC\$M_NM_OPER12	System-manager-defined operator functions
OPC\$L_MS_RQSTID	This longword field contains a user-supplied longword message code.	

Message Buffer Format for OPC\$_RQ_REPLY

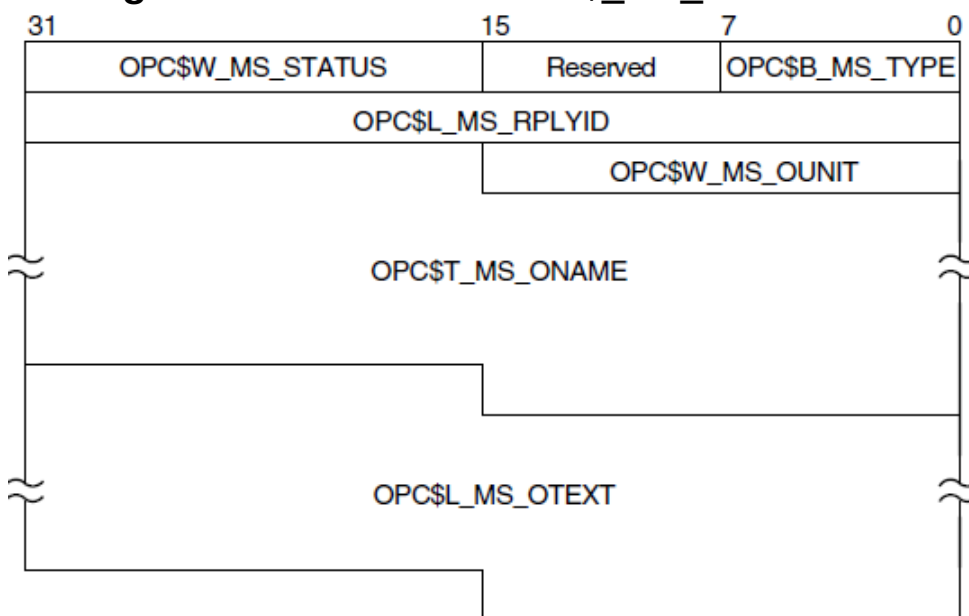

ZK-1727-GE

OPC\$B_MS_TYPE	This 1-byte field contains the request code OPC\$_RQ_REPLY.
Reserved	This 1-byte field is reserved for future use.
OPC\$W_MS_STATUS	This 2-byte field contains the low-order word of the longword condition value that \$SENDOPR returns in the mailbox specified by the <i>chan</i> argument. You can find a list of these longword condition values under Condition Values Returned in the Mailbox. To test the completion status, you need to extract the low-order word from the longword condition value and compare it to the contents of the OPC\$W_MS_STATUS field.
OPC\$L_MS_RPLYID	This 4-byte field contains a user-supplied message code.
OPC\$W_MS_OUNIT	This 2-byte field contains the unit number of the terminal to which the operator reply is to be sent. To obtain the unit number of the terminal, you can call \$GETDVI, specifying the DVI\$_FULLDEVNAM item

	<p>code. The information returned will consist of the node name and device name as a padded string. Because the unit number is found on the tail end of the string, you must parse the string. One way to do this is, starting from the tail end, to search for the first alphabetic character; the digits to the right of this alphabetic character constitute the unit number.</p> <p>After extracting the unit number, count the remaining characters in the string. Then, construct a counted ASCII string and use this for the following field, OPC\$T_MS_ONAME.</p>
OPC\$T_MS_ONAME	This variable-length field contains a counted ASCII string specifying the device name of the terminal that is to receive the operator reply. The maximum total length of the string is 14 bytes. See the preceding field description (OPC\$W_MS_OUNIT) to learn how to obtain the device name.
OPC\$L_MS_OTEXT	This variable-length field contains an ASCII string specifying operator-written text to be sent to the user terminal. The length of the string must be in the range 0 to 255 bytes. This field is optional.

Message Buffer Format for OPC\$_RQ_TERME

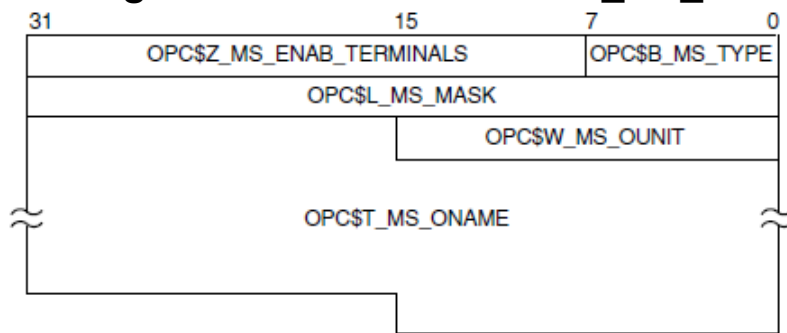

ZK-1728-GE

OPC\$B_MS_TYPE	This 1-byte field contains the request code OPC\$_RQ_TERME.												
OPC\$B_MS_ENAB_TERMINALS	This 3-byte field contains a user-supplied value. The value 0 indicates that the specified terminal is to be disabled for the specified operator classes. Any nonzero value indicates that the specified terminal is to be enabled for the specified operator classes.												
OPC\$B_MS_MASK	<p>This 4-byte field contains a 4-byte bit vector that specifies which operator terminal types are to be enabled or disabled for the specified terminal. The \$OPCDEF macro defines symbolic names for the operator terminal types. You construct the bit vector by specifying the desired symbolic names in a logical OR operation. Following is the symbolic name of each operator terminal type:</p> <table border="1"> <tr> <td>OPC\$M_NM_CARDS</td> <td>Card device operator</td> </tr> <tr> <td>OPC\$M_NM_CENTRL</td> <td>Central operator</td> </tr> <tr> <td>OPC\$M_NM_SECURITY</td> <td>Security operator</td> </tr> <tr> <td>OPC\$M_NM_CLUSTER</td> <td>OpenVMS Cluster operator</td> </tr> <tr> <td>OPC\$M_NM_DEVICE</td> <td>Device status information</td> </tr> <tr> <td>OPC\$M_NM_DISKS</td> <td>Disk operator</td> </tr> </table>	OPC\$M_NM_CARDS	Card device operator	OPC\$M_NM_CENTRL	Central operator	OPC\$M_NM_SECURITY	Security operator	OPC\$M_NM_CLUSTER	OpenVMS Cluster operator	OPC\$M_NM_DEVICE	Device status information	OPC\$M_NM_DISKS	Disk operator
OPC\$M_NM_CARDS	Card device operator												
OPC\$M_NM_CENTRL	Central operator												
OPC\$M_NM_SECURITY	Security operator												
OPC\$M_NM_CLUSTER	OpenVMS Cluster operator												
OPC\$M_NM_DEVICE	Device status information												
OPC\$M_NM_DISKS	Disk operator												

	OPC\$M_NM_NETWORK	Network operator
	OPC\$M_NM_TAPES	Tape operator
	OPC\$M_NM_PRINT	Printer operator
	OPC\$M_NM_OPER1 through OPC\$M_NM_OPER12	System-manager-defined operator functions
OPC\$W_MS_OUNIT	<p>This 2-byte field contains the unit number of the operator terminal to be enabled or disabled for the specified operator terminal types. To obtain the unit number of the terminal, you can call \$GETDVI, specifying the DVI\$_FULLDEVNAM item code. The information returned will consist of the node name and device name as a padded string. Because the unit number is found on the tail end of the string, you must parse the string. One way to do this is, starting from the tail end, to search for the first alphabetic character; the digits to the right of this alphabetic character constitute the unit number.</p> <p>After extracting the unit number, count the remaining characters in the string. Then, construct a counted ASCII string and use this for the following field, OPC\$T_MS_ONAME.</p>	
OPC\$T_MS_ONAME	<p>This variable-length field contains a counted ASCII string specifying the device name of the operator terminal to be enabled or disabled for the specified operator terminal types. The maximum total length of the string is 16 bytes. See the preceding field description (OPC\$W_MS_OUNIT) to learn how to obtain the device name.</p>	

Message Buffer Format for OPC\$_RQ_STATUS

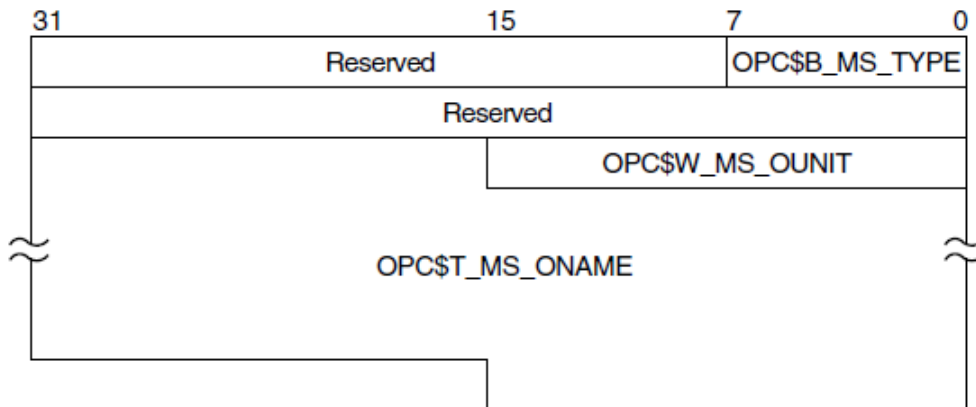

ZK-1729-GE

OPC\$B_MS_TYPE	This 1-byte field contains the request code OPC\$_RQ_STATUS.
Reserved	This 3-byte field is reserved for future use.
Reserved	This 4-byte field is reserved for future use.
OPC\$W_MS_OUNIT	This 2-byte field contains the unit number of the operator terminal whose status is to be requested. To obtain the unit number of the terminal, you can call \$GETDVI, specifying the DVI\$_FULLDEVNAM item code. The information returned will consist of the node name and device name as a padded string. Because the unit number is found on the tail end of the string, you must parse the string. One way to do this is, starting from the tail end, to search for

	<p>the first alphabetic character; the digits to the right of this alphabetic character constitute the unit number.</p> <p>After extracting the unit number, count the remaining characters in the string. Then, construct a counted ASCII string and use this for the following field, OPC\$T_MS_ONAME.</p>
OPC\$T_MS_ONAME	<p>This variable-length field contains a counted ASCII string specifying the device name of the operator terminal whose status is requested. The maximum total length of the string is 14 bytes. See the preceding field description (OPC\$W_MS_OUNIT) to learn how to obtain the device name.</p>

Message Buffer Format for OPC\$_RQ_LOGI

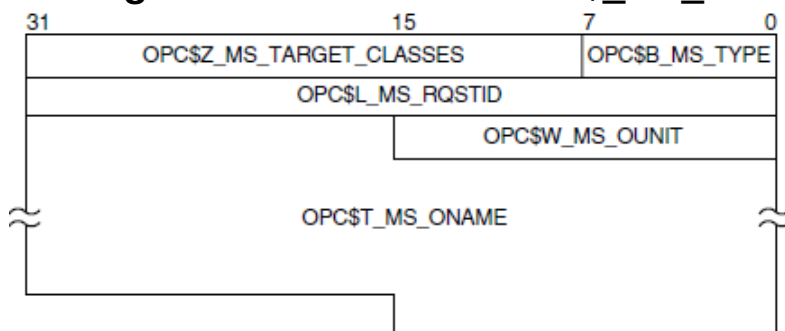

ZK-1730-GE

OPC\$B_MS_TYPE	This 1-byte field contains the request code OPC\$_RQ_LOGI.	
OPC\$B_MS_TARGET_CLASSES	This 3-byte field contains a 24-bit bit vector that CLASSES specifies which operator terminal types are to receive the cancellation request. The \$OPCDEF macro defines symbolic names for the operator terminal types. You construct the bit vector by specifying the desired symbolic names in a logical OR operation. Following is the symbolic name of each operator terminal type:	
	OPC\$M_NM_CARDS	Card device operator
	OPC\$M_NM_CENTRL	Central operator
	OPC\$M_NM_SECURITY	Security operator
	OPC\$M_NM_CLUSTER	OpenVMS Cluster operator
	OPC\$M_NM_DEVICE	Device status information
	OPC\$M_NM_DISKS	Disk operator
	OPC\$M_NM_NETWORK	Network operator
	OPC\$M_NM_TAPES	Tape operator
	OPC\$M_NM_PRINT	Printer operator
	OPC\$M_NM_OPER1 through OPC\$M_NM_OPER12	System-manager-defined operator functions
OPC\$L_MS_RQSTID	<p>This longword field contains a user-supplied value.</p> <p>The value 0 specifies that the current operator log file is to be closed and a new log file opened with all classes enabled (OPC\$B_MS_TARGET is ignored).</p>	

	<p>The value 1 specifies that the current operator log file is to be closed but no new log file is to be opened.</p> <p>The value 2 specifies that the classes in OPC\$B_MS_TARGET are added to the current operator log file classes. A log file is opened if necessary.</p> <p>The value 3 specifies that the operator classes in OPCB_MS_TARGET are to be removed from the operator log file classes. If all classes are removed, the log file is closed.</p>
OPC\$W_MS_OUNIT	<p>This 2-byte field contains the unit number of the operator terminal that is making the initialization request. To obtain the unit number of the terminal, you can call \$GETDVI, specifying the</p> <p>DVI\$_FULLDEVNAM</p> <p>item code. The information returned will consist of the node name and device name as a padded string. Because the unit number is found on the tail end of the string, you must parse the string. One way to do this is, starting from the tail end, to search for the first alphabetic character; the digits to the right of this alphabetic character constitute the unit number.</p> <p>After extracting the unit number, count the remaining characters in the string. Then, construct a counted ASCII string and use this for the following field, OPC\$T_MS_ONAME.</p>
OPC\$T_MS_ONAME	<p>This variable-length field contains a counted ASCII string specifying the device name of the operator terminal that is making the initialization request. The maximum total length of the string is 14 bytes. See the preceding field description (OPC\$W_MS_OUNIT) to learn how to obtain the device name.</p>

chan

OpenVMS usage: channel
type: word (unsigned)
access: read only
mechanism: by value

Channel assigned to the mailbox to which the reply is to be sent. The *chan* argument is a longword value containing the number of the channel. If you do not specify *chan* or specify it as the value 0 (the default), no reply is sent.

If a reply from the operator is desired, you must specify the *chan* argument.

Description

The \$SNDOPR service performs the following functions:

- Sends a user request to operator terminals
- Sends a user cancellation request to operator terminals

- Sends an operator reply to a user terminal
- Enables an operator terminal
- Displays the status of an operator terminal
- Initializes the operator log file

This system service requires system dynamic memory; it cannot be called from kernel mode.

The general procedure for using this service is as follows:

1. Construct the message buffer and place its final length in the first word of the buffer descriptor.
2. Call the \$SNDOPR service.
3. Check the condition value returned in R0 to make sure the request was successfully made.
4. Issue a read request to the mailbox specified, if any.
5. When the read operation completes, check the 2-byte condition value in the OPC\$W_MS_STATUS field to make sure that the operation was performed successfully.

The format of messages displayed on operator terminals follows:

```
%%%%%%%%%% OPCOM   dd-mmm-yyyy hh:mm:ss.cc  
message specific information
```

The following example shows the message displayed on a terminal as a result of a request to enable that terminal as an operator terminal:

```
%%%%%%%%%% OPCOM   30-DEC-2001 13:44:40.37  
Operator _NODE$LTA5: has been enabled, username HOEBLE
```

The following example shows the message displayed on an operator terminal as a result of a request to display the status of that operator terminal:

```
%%%%%%%%%% OPCOM   30-DEC-2001 12:11:10.48  
Operator status for operator _NODE$OPA0:  
CENTRAL, PRINTER, TAPES, DISKS, DEVICES, CARDS, CLUSTER, SECURITY,  
OPER1, OPER2, OPER3, OPER4, OPER5, OPER6, OPER7, OPER8, OPER9,  
OPER10, OPER11, OPER12
```

The following example shows the message displayed on an operator terminal as a result of a user request:

```
%%%%%%%%%% OPCOM   30-DEC-2001 12:57:32.25  
Request 1285, from user ROSS on NODE_NAME  
Please mount device _NODE$DMA0:
```

Required Access or Privileges

OPER privilege is required for the following functions:

- Enabling a terminal as an operator's terminal
- Replying to or canceling a user's request
- Initializing the operator communication log file

In addition, the operator must have SECURITY privilege to affect security functions.

Required Quota

None

Related Services

\$ALLOC, \$ASSIGN, \$BRKTHRU, \$BRKTHRUW, \$CANCEL, \$CREMBX, \$DALLOC, \$DASSGN, \$DELMBOX, \$DEVICE_SCAN, \$DISMOU, \$GETDVI, \$GETDVIW, \$GETMSG, \$GETQUI, \$GETQUIW, \$INIT_VOL, \$MOUNT, \$PUTMSG, \$QIO, \$QIOW, \$SNDERR, \$SNDJBC, \$SNDJBCW

Condition Values Returned

SS\$_NORMAL

The service completed successfully.

SS\$_ACCVIO

The message buffer or buffer descriptor cannot be read by the caller.

SS\$_BADPARAM

The specified message has a length of 0 or has more than 986 bytes.

SS\$_DEVNOTMBX

The channel specified is not assigned to a mailbox.

SS\$_INSFMEM

The service was called from kernel mode or the system dynamic memory is insufficient for completing the service.

SS\$_IVCHAN

You specified an invalid channel number. An invalid channel number is one that is 0 or a number larger than the number of channels available.

SS\$_MBFULL

The mailbox used to support communication is full. Retry at a later time.

OPC\$_NOPERATOR

The service completed successfully; the Operator Communications Manager (OPCOM) is not running and the message will not be sent. Note that OPC\$_NOPERATOR is a success status and must be tested for explicitly.

SS\$_NOPRIV

The process does not have the privilege to reply to or cancel a user's request; the process does not have read/write access to the specified mailbox; or the channel was assigned from a more privileged access mode.

Condition Values Returned in the Mailbox

OPC\$_BLANKTAPE

The service completed successfully; the operator responded with the DCL command REPLY/
BLANK_TAPE=n.

OPC\$_INITAPE

The service completed successfully; the operator responded with the DCL command REPLY/
INITIALIZE_TAPE=n.

OPC\$_NOPERATOR

The service completed successfully; no operator terminal was enabled to receive the message.

OPC\$_RQSTCMLTE

The service completed successfully; the operator completed the request.

OPC\$_RQSTPEND

The service completed successfully; the operator will perform the request when possible.

OPC\$_RQSTABORT

The operator could not satisfy the request.

OPC\$_RQSTCAN

The caller canceled the request.

Examples

```
1. #include <descrip.h> /* VMS string descriptors */
   #include <lib$routines.h> /* VMS LIB$ routine prototypes */
   #include <opcdef.h> /* $SNDOPR request structures and definitions
   */
   #include <ssdef.h> /* VMS SS$_x status values */
   #include <stsdef.h> /* $VMS_STATUS_SUCCESS */
   #include <starlet.h> /* VMS system service prototypes */
   #include <stddef.h> /* Define offsetof */
   #include <stdlib.h> /* malloc, free, et. al. */
   #include <string.h> /* string functions, memcpy, et. al. */

main(int argc, char *argv[])
{
    int status; /* Status of system calls */
    short length = 0; /* Length of message text */

    union /* Target OPC$_ classes bitmask
    */
    {
        int longword_value; /* Longword, for use
        with OPC$_ values */
        char byte_value[3]; /* By byte, to
        load opc$_ms_target_classes */
    } target_classes;
```

```

    struct _opcdef *sndopr_rqst;          /* Pointer to $SNDOPR message
buffer */

    /*
    * Descriptors for input message text string, $SNDOPR message
buffer, and prompt.
    */
    struct dsc$descriptor input_desc =
{ 0, DSC$K_DTYPE_T, DSC$K_CLASS_S, 0 };
    struct dsc$descriptor req_desc =
{ 0, DSC$K_DTYPE_T, DSC$K_CLASS_S, 0 };
    $DESCRIPTOR(prompt_desc, "Request> ");

    /*
    * Check for too many arguments on command line
    */
    if (argc > 2)
        return SS$_OVRMAXARG;

    /*
    * If provided on the command line, use that as the message string.
    */
    if (argc > 1)
    {
        length = strlen(argv[1]);
        input_desc.dsc$a_pointer = argv[1];
    }

    /*
    * If no message text so far, prompt the user for the message text.
    * Use a dynamic string descriptor to contain the supplied text.
    */
    while (length == 0)
    {
        input_desc.dsc$b_class = DSC$K_CLASS_D;
        status = lib$get_input(&input_desc, &prompt_desc, &length);
        if ( !$VMS_STATUS_SUCCESS(status) )
            return status;
    };

    /*
    * Allocate a $SNDOPR message structure with enough room for the
    * message text and the fixed header for a OPC$_RQ_RQST message.
    */
    sndopr_rqst = malloc( length + offsetof(struct
_opcdef,opc$l_ms_text) );
    if (sndopr_rqst == 0)
        return SS$_INSFMEM;

    /*
    * Fill in the $SNDOPR message structure, including the text.
    */
    sndopr_rqst->opc$b_ms_type = OPC$_RQ_RQST;
    sndopr_rqst->opc$l_ms_rqstid = 0;

    target_classes.longword_value = OPC$_NM_CENTRL;

```

```

    sndopr_rqst->opc$z_ms_target_classes[0] =
target_classes.byte_value[0];
    sndopr_rqst->opc$z_ms_target_classes[1] =
target_classes.byte_value[1];
    sndopr_rqst->opc$z_ms_target_classes[2] =
target_classes.byte_value[2];

    memcpy(&sndopr_rqst->opc$l_ms_text, input_desc.dsc$a_pointer,
length);

    /*
    * Set up the descriptor for the $SNDOPR message structure and call
    * the $SNDOPR service.
    */
    req_desc.dsc$w_length = length + offsetof(struct
_opcdef,opc$l_ms_text);
    req_desc.dsc$a_pointer = (char *) sndopr_rqst;

    status = sys$sndopr(&req_desc, 0);

    /*
    * Clean up time. Free the $sndopr request block. If we got a
dynamic
    * string for the input message text, free that too.
    */
    free( sndopr_rqst);

    if ( input_desc.dsc$b_class == DSC$K_CLASS_D )
        lib$free1_dd( (unsigned __int64 *) &input_desc );

    return status;
}

```

This example allows you to build an operator request and send the request to the operator.

2. IMPLICIT NONE

```

! Symbol definitions
INCLUDE '($DVIDEF) '
INCLUDE '($OPCDEF) '

! Structures for SNDOPR
STRUCTURE /MESSAGE/
UNION
MAP
    BYTE TYPE,
2    ENABLE(3)
    INTEGER*4 MASK
    INTEGER*2 OUNIT
    CHARACTER*14 ONAME
END MAP
MAP
    CHARACTER*24 STRING
END MAP
END UNION
END STRUCTURE
RECORD /MESSAGE/ MSGBUF

```

```

! Length of MSGBUF.ONAME
INTEGER*4 ONAME_LEN

! Status and routines
INTEGER*4 STATUS,
2          LIB$GETDVI,
2          SYS$SNDOPR

! Type
MSGBUF.TYPE = OPC$_RQ_TERME
! Enable
MSGBUF.ENABLE(1) = 1
! Operator type
MSGBUF.MASK = OPC$_NM_OPER1
! Terminal unit number
STATUS = LIB$GETDVI (DVI$_UNIT,
2
2          'SYS$OUTPUT',
2          MSGBUF.OUNIT,,)
IF (.NOT. STATUS) CALL LIB$SIGNAL (%VAL(STATUS))
! Terminal name
STATUS = LIB$GETDVI (DVI$_FULLDEVNAM,
2
2          'SYS$OUTPUT',,
2          MSGBUF.ONAME,
2          ONAME_LEN)
IF (.NOT. STATUS) CALL LIB$SIGNAL (%VAL(STATUS))
! Remove unit number from ONAME and set up counted string
ONAME_LEN = ONAME_LEN - 3
MSGBUF.ONAME(2:ONAME_LEN+1) = MSGBUF.ONAME(1:ONAME_LEN)
MSGBUF.ONAME(1:1) = CHAR(ONAME_LEN)
! Call $SNDOPR
STATUS = SYS$SNDOPR (MSGBUF.STRING,)
IF (.NOT. STATUS) CALL LIB$SIGNAL(%VAL(STATUS))
END

```

This VSI Fortran for OpenVMS program enables the current terminal to receive OPER1 operator messages.

\$SPACE

Skip Tape File — The Space service lets you space (skip) a tape file forward or backward a specified number of blocks.

For additional information about this service, see the *VSI OpenVMS Record Management Services Reference Manual*.

\$START_ALIGN_FAULT_REPORT (Alpha and Integrity servers)

Start Alignment Fault Reporting — On Alpha and Integrity server systems, initializes user image alignment fault reporting.

Format

```
SYS$START_ALIGN_FAULT_REPORT  
    report_method , report_buffer , buffer_length
```

C Prototype

```
int sys$start_align_fault_report  
    (int report_method, void *report_buffer, int buffer_length);
```

Arguments

report_method

OpenVMS usage: longword_signed
type: longword (signed)
access: read
mechanism: by value

Method by which image alignment faults are to be reported. The following table shows valid values for the *report_method* argument.

Value	Meaning
AFR\$C_BUFFERED	Alignment fault PCs and fault addresses are saved in a user-supplied buffer.
AFR\$C_EXCEPTION	Alignment faults are elevated to user mode exceptions.

report_buffer

OpenVMS usage: address
type: longword (unsigned)
access: read
mechanism: by reference

The 32-bit address of the buffer into which to write the fault data. The *report_buffer* argument is needed only if the value of the *report_method* argument is AFR\$C_BUFFERED.

buffer_length

OpenVMS usage: byte count
type: longword (signed)
access: read
mechanism: by value

Length of the buffer specified in the *report_buffer* argument. The buffer must have a minimum size of AFR\$K_USER_LENGTH + 32. However, a larger buffer allows for more information to be collected.

Description

The Start Alignment Fault Reporting service initializes user image alignment fault reporting.

The `$START_ALIGN_FAULT_REPORT` service allows the user to gather alignment fault data for one image. Reporting is enabled for the life of the image. When the image terminates, the alignment fault reporting is disabled.

User alignment fault data can be written to a buffer or broadcast as an informational exception message.

If the `AFR$C_BUFFERED` value is given in the `report_method` buffer, alignment fault PCs and fault addresses are saved in a user-supplied buffer.

The following diagram illustrates the format in which user alignment fault data is stored in the buffer.

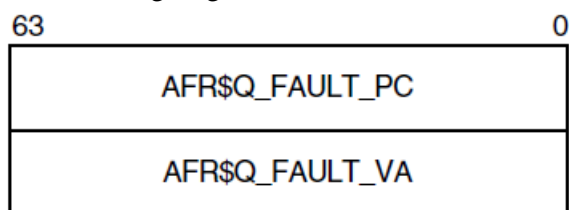

ZK-4983A-GE

If the `AFR$C_EXCEPTION` value is given in the `report_method` argument, alignment faults are elevated to user mode exceptions. These exceptions can be trapped in a handler. Otherwise, an informational exception message might be broadcast and the program continues to execute.

Required Access or Privileges

None

Required Quota

None

Related Services

`$GET_ALIGN_FAULT_DATA`, `$GET_SYS_ALIGN_FAULT_DATA`,
`$INIT_SYS_ALIGN_FAULT_REPORT`, `$PERM_DIS_ALIGN_FAULT_REPORT`,
`$PERM_REPORT_ALIGN_FAULT`, `$STOP_ALIGN_FAULT_REPORT`,
`$STOP_SYS_ALIGN_FAULT_REPORT`

Condition Values Returned

SS\$_NORMAL

The service completed successfully.

SS\$_ACCVIO

The buffer specified in the `report_buffer` argument is not accessible.

SS\$_AFR_ENABLED

The service has already been called for this image.

SS\$_ARG_GTR_32_BITS

The report buffer's virtual address lies in 64-bit virtual address space.

SS\$_ALIGN

The buffer specified in the *report_buffer* argument is not quadword aligned.

SS\$_BADPARAM

The buffer size is smaller than that defined by the *AFR\$_USER_LENGTH + 32* symbol.

Example

```
#include <afrdef>
#include <stdio>
#include <ssdef>

#define USER_BUFFER_ITEMS 10
#define GET_BUFFER_SIZE USER_BUFFER_ITEMS*AFR$_USER_LENGTH
#define SAVE_BUFFER_SIZE 128+64

#define fault_pc afr$l_fault_pc_l
#define fault_va afr$l_fault_va_l

static int usr_buff_len;
static char *usr_buff;
static int rep_method;

void
cause_af()
{
    int    addr;
    int    *ptr;
    int    arr[2];

    addr = (int) &arr[0];
    ptr = (int *) ++addr;
    *ptr = 1;    /* cause alignment fault */
}

main()
{
    int            i;
    char          get_buffer[GET_BUFFER_SIZE];
    struct afrdef *data_item;
    int           offset;
    int           status;
    int           return_size;

    rep_method = AFR$_C_BUFFERED;
    usr_buff_len = SAVE_BUFFER_SIZE;
    usr_buff = (char *)malloc (usr_buff_len);
    if(( status = sys$start_align_fault_report (rep_method, usr_buff,
        usr_buff_len))
        != SS$_NORMAL) return(status);

    for (i=0;i<USER_BUFFER_ITEMS;i++)
        cause_af();
}
```

```
while (((status = sys$get_align_fault_data (get_buffer,
      GET_BUFFER_SIZE,
      &return_size)) > 0) &&
      (return_size > 0)) {
  /* got some data, print it */
  offset = 0;
  while (offset < return_size) {
    data_item = (struct afrdef *)(&get_buffer[offset]);
    printf ("Alignment fault at PC = %8.8X, VA = %8.8X\n",
      data_item->fault_pc, data_item->fault_va);
    offset += AFR$K_USER_LENGTH;
  }
}

return (status);
}
```

This example shows how to use the `$START_ALIGN_FAULT_REPORT` service to initialize user image alignment fault reporting on Alpha and Integrity server systems.

\$START_BRANCH

Start Branch — Adds a new branch to a transaction.

Format

```
SYS$START_BRANCH
  [efn] , [flags] , iosb , [astadr] , [astprm] , tid , tm_name
  , bid [, [timeout], [acmode], [tx_class]]
```

C Prototype

```
int sys$start_branch
(unsigned int efn, unsigned int flags, struct _iosb *iosb,
void (*astadr)(__unknown_params), int astprm, unsigned int tid [4],
void *tm_name, unsigned int bid [4],...);
```

Arguments

efn

OpenVMS usage: ef_number
type: longword (unsigned)
access: read only
mechanism: by value

Number of the event flag that is set when the service completes. If this argument is omitted, event flag 0 is used.

flags

OpenVMS usage: mask_longword
type: longword (unsigned)

access: read only
mechanism: by value

Flags specifying options for the service. The *flags* argument is a longword bit mask in which each bit corresponds to an option flag. The \$DDTMDEF macro defines symbolic names for these option flags, described in Table 14. All undefined bits must be 0. If this argument is omitted, no flags are used.

Table 14. \$START_BRANCH Option Flags

Flag Name	Description
DDTM\$M_BRANCH_UNSYNCHED	Specifies that the new branch is unsynchronized. If this flag is clear, the new branch is synchronized.
DDTM\$M_NONDEFAULT	Set this flag if you do not want the transaction to be the default transaction of the calling process. If this flag is clear, the transaction becomes the default transaction of the calling process. An error is returned if this flag is clear and the calling process has an current default transaction.
DDTM\$M_SYNC	Specifies successful synchronous completion by returning SS\$_SYNCH. When SS\$_SYNCH is returned, the AST routine is not called, the event flag is not set, and the I/O status block is not filled in.

iosb

OpenVMS usage: io_status_block
type: quadword (unsigned)
access: write only
mechanism: by reference

The I/O status block in which the completion status of the service is returned as a condition value. See the Condition Values Returned section.

The following diagram shows the structure of the I/O status block:

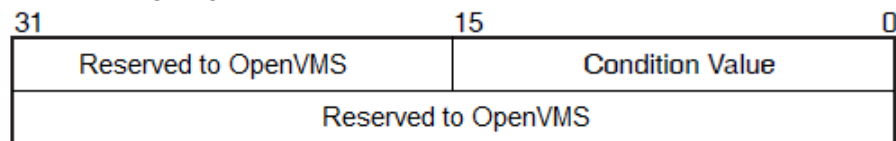

VM-0778A-A1

astadr

OpenVMS usage: ast_procedure
type: procedure entry mask
access: call without stack unwinding
mechanism: by reference

The AST routine executed when the service completes, if SS\$_NORMAL is returned in R0. The *astadr* argument is the address of the entry mask of this routine. The routine is executed in the same access mode as that of the caller of the \$START_BRANCH service.

astprm

OpenVMS usage: user_arg
type: longword (unsigned)
access: read only
mechanism: by value

The AST parameter passed to the AST routine specified by the *astadr* argument.

tid

OpenVMS usage: trans_id
type: octaword (unsigned)
access: read only
mechanism: by reference

The identifier (TID) of the transaction to which the new branch will be added.

tm_name

OpenVMS usage: char_string
type: character-coded text string
access: read only
mechanism: by descriptor--fixed-length string descriptor

The name of the node on which the call was made to \$ADD_BRANCH that authorized the new branch to be added to the transaction. Note that this cannot be a cluster alias.

To ensure smooth operation in a mixed-network environment, refer to the chapter entitled Managing DECdtm Services in the *VSI OpenVMS System Manager's Manual*, for information on defining node names.

bid

OpenVMS usage: branch_id
type: octaword (unsigned)
access: read only
mechanism: by reference

The identifier (BID) of the new branch that is to be added to the transaction.

An BID value of zero is invalid.

timeout

OpenVMS usage: date_time
type: quadword (unsigned)
access: read only
mechanism: by reference

Reserved to OpenVMS.

acmode

OpenVMS usage: `access_mode`
type: `longword (unsigned)`
access: `read only`
mechanism: `by value`

The access mode of the new branch in this process. This is the least privileged mode that a caller must be in to remove this branch from the transaction by calling `$END_BRANCH`. Note that it can be removed from the transaction by calling `$ABORT_TRANS` from any access mode.

This argument only influences the access mode of the first branch in this process. Subsequent branches have the same access mode as the first. The access mode of the new branch is the least privileged of:

- The access mode of the caller.
- The access mode specified by the `acmode` argument.

Note that if a branch already exists in this process, then neither the access mode of the caller nor the access mode specified by the `acmode` argument may be less privileged than that branch.

The default value of this argument is the access mode of the caller.

tx_class

OpenVMS usage: `char_string`
type: `character-coded text string`
access: `read only`
mechanism: `by descriptor--fixed-length string descriptor`

A string that specifies the transaction class for the transaction on the local node if the transaction does not already have a transaction class on the local node. This string is passed in the event reports delivered to Resource Manager identifiers (RMIs) and Resource Manager (RM) participants on the local node.

This argument is ignored if the transaction already has a transaction class on the local node.

This string must be no longer than 31 characters.

Description

The `$START_BRANCH` system service:

- Adds a new branch running in the calling process to the specified transaction.
- Adds the local DECdtm transaction manager to the specified transaction if the local DECdtm transaction manager is not already a participant in that transaction.
- Sets the default transaction of the calling process to the new transaction, if the `DDTM$M_NONDEFAULT` flag is clear and the process does not have a default transaction.
- Delivers a transaction started event to each RMI in the calling process that meets both of the following conditions:

- Requested Transaction Started events for the corresponding transaction type (default or non-default)
- Has an access mode that is the same as or more privileged than that specified in this call to \$START_BRANCH.

The new branch should have been previously authorized. Authorization is provided either by a matching call to \$JOIN_RM with the DDTM\$M_COORDINATOR flag set or by a matching call to \$ADD_BRANCH. Two calls, one to \$ADD_BRANCH and one to \$START_BRANCH or one to \$JOIN_RM and one to \$START_BRANCH, are said to be matching when the following conditions are true:

- The same TID values are passed to both calls.
- The BID returned by the call to \$ADD_BRANCH or \$JOIN_RM is the same as that passed to the call to \$START_BRANCH.
- The call to \$START_BRANCH is made on the node identified by the *tm_name* argument passed to the call to \$ADD_BRANCH or on the node on which the call to \$JOIN_RM was made.
- The call to \$ADD_BRANCH or \$JOIN_RM is made on the node identified by the *tm_name* argument passed to the call to \$START_BRANCH.

\$START_BRANCH does not check that there has been a matching call to \$ADD_BRANCH or \$JOIN_RM unless the *tm_name* argument passed to \$START_BRANCH specifies the local node.

Note

The atomicity of the transaction is not guaranteed if there is a call to \$START_BRANCH that does not have a matching call to \$ADD_BRANCH or \$JOIN_RM.

Preconditions for the successful completion of \$START_BRANCH are:

- The local node must have a DECdtm transaction log.
- The TP_SERVER process must be running on the local node.
- There must not have been a successful call to \$START_BRANCH on the local node that passed the specified BID.
- If the *tm_name* argument specifies the local node, there must have been a matching call to \$ADD_BRANCH or \$JOIN_RM on the local node.
- If the DDTM\$M_NONDEFAULT flag is clear, the calling process must not have an unended default transaction.
- If this process already contains a branch of this transaction, then the access mode of the caller must be the same as or more privileged than the access mode of that branch.

\$START_BRANCH may fail because:

- Preconditions were not met.
- An abort event occurred for the transaction.

- A call to \$END_TRANS to end the transaction is in progress and it is too late to add a new branch to the transaction.
- The DDTM\$M_NONDEFAULT flag was clear and a call to \$SET_DEFAULT_TRANS by the calling process is in progress.

When \$START_BRANCH completes successfully:

- A new branch running in the calling process has been added to the transaction.
- All Transaction Started events reported to RMIs in the calling process have been acknowledged.
- If the DDTM\$M_NONDEFAULT flag was clear, the transaction is the default transaction of the calling process.

A branch may:

- Invoke resource manager operations, explicitly passing the TID.
- Invoke resource manager operations without specifying the TID, if the transaction is the default transaction of the calling process, and the resource manager supports default transactions.
- Call \$ADD_BRANCH to authorize another branch to be added to the transaction.

(The way to invoke a resource manager operation is defined by the interfaces provided by the resource manager; see the resource manager documentation.)

A synchronized branch is removed from the transaction by calling \$END_BRANCH, specifying the appropriate BID and TID. An unsynchronized branch is removed from the transaction by DECdtm during commit or abort processing.

The branch is also removed from the transaction (and the transaction aborted):

- On termination of the current image or process.
- On successful completion of a call to \$ABORT_TRANS in the calling process that passes the appropriate TID and BID.

There is also a wait form of the service, \$START_BRANCHW.

Required Privileges

None

Required Quotas

BYTLM, ASTLM

Related Services

\$ABORT_TRANS, \$ABORT_TRANSW, \$ACK_EVENT, \$ADD_BRANCH, \$ADD_BRANCHW, \$CREATE_UID, \$DECLARE_RM, \$DECLARE_RMW, \$END_BRANCH, \$END_BRANCHW, \$END_TRANS, \$END_TRANSW, \$FORGET_RM, \$FORGET_RMW, \$GETDTI, \$GETDTIW, \$GET_DEFAULT_TRANS, \$JOIN_RM, \$JOIN_RMW, \$SETDTI, \$SETDTIW, \$SET_DEFAULT_TRANS, \$SET_DEFAULT_TRANSW, \$START_BRANCHW, \$START_TRANS, \$START_TRANSW, \$TRANS_EVENT, \$TRANS_EVENTW

Condition Values Returned

SS\$_NORMAL

If returned in R0, the request was successfully queued. If returned in the I/O status block, the service completed successfully.

SS\$_SYNCH

The service completed successfully and synchronously (returned only if the DDTM\$_SYNC flag is set).

SS\$_ACCVIO

An argument was not accessible to the caller.

SS\$_ALRCURTID

Either:

- An attempt was made to make the transaction specified by the *tid* argument the default transaction (the DDTM\$_NONDEFAULT flag was clear) when the calling process had an unended default transaction.
- The DDTM\$_NONDEFAULT flag was clear and a call to \$SET_DEFAULT_TRANS by the calling process was in progress.

SS\$_BADPARAM

Either the options flags were invalid or the *tid* argument was omitted but the *bid* argument was not zero.

SS\$_BRANCHSTARTED

There has already been a call to \$START_BRANCH on the local node specifying that TID and BID (returned only if the node specified by the *tm_name* argument was the local node).

SS\$_CONNCFAIL

The node specified by the *tm_name* argument was not the local node, and there was no communications link between the DECdtm transaction managers on the local node and the specified node.

SS\$_EXASTLM

The process AST limit (ASTLM) was exceeded.

SS\$_EXQUOTA

The job buffered I/O byte limit quota (BYTLM) was exceeded.

SS\$_ILLEFC

The event flag number was invalid.

SS\$_INSFARGS

A required argument was missing.

SS\$_INSFMEM

There was insufficient system dynamic memory for the operation.

SS\$_INVBUFLN

The string passed in the *tx_class* argument was longer than 31 characters, or the string passed in the *tm_name* argument was longer than 256 characters.

SS\$_NOLOG

The local node did not have a transaction log.

SS\$_NOSUCHBID

Either:

- The specified BID was not returned by any call to \$ADD_BRANCH or \$JOIN_RM on the local node (returned only if the node specified by the *tm_name* argument was the local node).
- An BID of zero was supplied.

SS\$_NOSUCHTID

The local node did not have any branches in the specified transaction (returned only if the node specified by the *tm_name* argument was the local node).

SS\$_TPDISABLED

The TP_SERVER process was not running on the local node.

SS\$_WRONGSTATE

The transaction was in the wrong state for the attempted operation because either:

- An abort event has occurred for the transaction.
- A call to \$END_TRANS to end the transaction is in progress and it is now too late to add a new branch to the transaction.

\$START_BRANCHW

Start Branch and Wait — Adds a new branch to a transaction.

\$START_BRANCHW always waits for the request to complete before returning to the caller. Other than this, it is identical to \$START_BRANCH.

Format

```
SYSS$START_BRANCHW
    [efn] , [flags] , iosb , [astadr] , [astprm] , tid , tm_name
    , bid [, [timeout] , [acmode] , [tx_class]]
```

C Prototype

```
int sys$start_branchw
```

```
(unsigned int efn, unsigned int flags, struct _iosb *iosb,
 void (*astadr)(__unknown_params), int astprm, unsigned int tid [4],
 void *tm_name, unsigned int bid [4],...);
```

\$START_TRANS

Start Transaction — Starts a new transaction.

Format

```
SYSS$START_TRANS
  [efn] , [flags] , iosb [, [astadr] , [astprm] , [tid] , [timeout] , [acmode]
  , [tx_class]]
```

C Prototype

```
int sys$start_trans
  (unsigned int efn, unsigned int flags, struct _iosb *iosb,...);
```

Arguments

efn

OpenVMS usage: ef_number
 type: longword (unsigned)
 access: read only
 mechanism: by value

Number of the event flag that is set when the service completes. If this argument is omitted, event flag 0 is set.

flags

OpenVMS usage: mask_longword
 type: longword (unsigned)
 access: read only
 mechanism: by value

Flags specifying options for the service. The flags argument is a longword bit mask in which each bit corresponds to an option flag. The \$DDTMDEF macro defines symbolic names for these option flags, which are described in the following table:

Flag	Description
DDTM\$_NONDEFAULT	Set this flag if you do not want the new transaction to be the default transaction of the calling process. An error is returned if this flag is set and the <i>tid</i> argument is zero or omitted.

Flag	Description
	If this flag is clear, the new transaction becomes the default transaction of the calling process. An error is returned if this flag is clear and the calling process already has a default transaction.
DDTM\$M_SYNC	Set this flag to specify that successful synchronous completion is to be indicated by returning SS\$_SYNCH. When SS\$_SYNCH is returned, the AST routine is not called, the event flag is not set, and the I/O status block is not filled in.

iosb

OpenVMS usage: io_status_block
type: quadword (unsigned)
access: write only
mechanism: by reference

I/O status block in which the completion status of the service is returned as a condition value. See the Condition Values Returned section.

The following diagram shows the structure of the I/O status block.

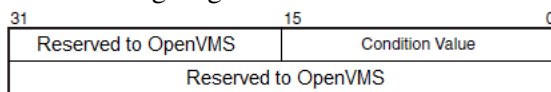

VM-0458A-AI

astadr

OpenVMS usage: ast_procedure
type: procedure entry mask
access: call without stack unwinding
mechanism: by reference

AST routine that is executed when the service completes if SS\$_NORMAL is returned in R0. The *astadr* argument is the address of this routine. This routine is executed in the same access mode of the caller of the \$START_TRANS service.

astprm

OpenVMS usage: user_arg
type: longword (unsigned)
access: read only
mechanism: by value

AST parameter that is passed to the AST routine specified by the *astadr* argument.

tid

OpenVMS usage: trans_id
type: octaword (unsigned)
access: write only

mechanism: by reference

Address of an octaword in which the service returns the identifier (TID) of the new transaction.

No other call to \$START_TRANS on any node ever returns the same TID value.

The default value of this argument is zero. An error is returned if the DDTM\$M_NONDEFAULT flag is set and this argument is either omitted or zero.

timeout

OpenVMS usage: date_time
type: quadword (unsigned)
access: read only
mechanism: by reference

Timeout for the new transaction. This is the time at which the DECdtm transaction manager is to abort the transaction if the transaction has not already committed.

A positive time value specifies an absolute time. The absolute value of a negative time specifies an offset (delta time) from the current time.

The transaction is aborted at the next timer interval if you specify either a zero time value or any time in the past. If this argument is omitted, the new transaction has no timeout.

acmode

OpenVMS usage: access_mode
type: longword (unsigned)
access: read only
mechanism: by value

An access mode of the new branch of the new transaction.

An access mode is maintained for each transaction per process. All branches in a transaction in a process have the same access mode. Subsequent operations do not alter it. The access mode of a branch is the least privileged mode in which a successful call to \$END_TRANS may be made.

Note that the transaction may be aborted by a call to \$ABORT_TRANS from any access mode.

The access mode of the branch is the least privileged of the following:

- The access mode of the caller
- The access mode specified by the *acmode* argument

If the *acmode* argument is omitted, the access mode of the new branch is the same as that of the caller.

tx_class

OpenVMS usage: char_string

type: character-coded text string
access: read only
mechanism: by descriptor – fixed-length string descriptor

A string that specifies the transaction class for the new transaction on the local node. This string is passed in the event reports delivered to RMIs and RM participants on the local node.

This string must be no longer than 31 characters. If this argument is omitted or the string is of length zero, the new transaction has no transaction class on the local node. In this case, the class of the transaction on the local node can be specified by a subsequent call to `$START_BRANCH` on that node.

Description

The `$START_TRANS` system service starts a new transaction whose commit or abort processing is to be coordinated by the local DECdtm transaction manager. The service:

- Adds a branch running in the calling process to the new transaction. The identifier (BID) of the new branch is 0.
- Sets the default transaction of the calling process to the new transaction, if the `DDTM$M_NONDEFAULT` flag is clear and the process does not have a default transaction.
- Delivers an event of type Transaction Started to each RMI in the calling process that requested Transaction Started events and has an access mode that is the same as or more privileged than that specified in this call to `$START_TRANS`. See the description of the **acmode** argument.

The event delivered to all such RMIs is either a default transaction-started event or a nondefault transaction-started event, depending on whether the `DDTM$M_NONDEFAULT` flag is clear or not.

Preconditions for the successful completion of `$START_TRANS` are:

- The local node must have a DECdtm transaction log.
- The `TP_SERVER` process must be running on the local node.
- If the `DDTM$M_NONDEFAULT` flag is clear, the calling process must not have an unended default transaction.

`$START_TRANS` may fail for various reasons including:

- Preconditions were not met.
- The `DDTM$M_NONDEFAULT` flag was clear and a call to `$SET_DEFAULT_TRANS` by the calling process is in progress.

When `$START_TRANS` completes successfully:

- A new transaction has started, with a unique identifier.
- The transaction has a single branch, with a BID of 0.
- All Transaction Started events reported to RMIs in the calling process have been acknowledged.
- If the `DDTM$M_NONDEFAULT` flag was clear, the transaction is the default transaction of the calling process.

A branch may:

- Invoke resource manager operations, explicitly passing the TID.
- Invoke resource manager operations without specifying the TID, if the transaction is the default transaction of the calling process, and the resource manager supports default transactions.
- Call `$ADD_BRANCH` to authorize another branch to be added to the transaction.

(The way to invoke a resource manager operation is defined by the interfaces provided by the resource manager. For additional information, see the resource manager documentation.)

DECdtm cannot commit the transaction until the process calls `$END_TRANS`.

The transaction is aborted:

- On termination of the current image or process.
- On successful completion of a call to `$ABORT_TRANS` in the calling process, specifying a BID of 0.

There is also a wait form of the service, `$START_TRANSW`.

Required Access or Privileges

None

Required Quotas

ASTLM, BYTLM

Related Services

`$ABORT_TRANS`, `$ABORT_TRANSW`, `$ACK_EVENT`, `$ADD_BRANCH`, `$ADD_BRANCHW`, `$CREATE_UID`, `$DECLARE_RM`, `$DECLARE_RMW`, `$END_BRANCH`, `$END_BRANCHW`, `$END_TRANS`, `$END_TRANSW`, `$FORGET_RM`, `$FORGET_RMW`, `$GETDTI`, `$GETDTIW`, `$GET_DEFAULT_TRANS`, `$JOIN_RM`, `$JOIN_RMW`, `$SETDTI`, `$SETDTIW`, `$SET_DEFAULT_TRANS`, `$SET_DEFAULT_TRANSW`, `$START_BRANCH`, `$START_BRANCHW`, `$START_TRANSW`, `$TRANS_EVENT`, `$TRANS_EVENTW`

Condition Values Returned

SS\$_NORMAL

If returned in R0, the request was successfully queued. If returned in the I/O status block, the service completed successfully.

SS\$_SYNCH

The service completed successfully and synchronously (returned only if the `DDTM$M_SYNC` flag is set).

SS\$_ACCVIO

An argument was not accessible to the caller.

SS\$_ALCURTID

Either:

- An attempt was made to start a default transaction (the DDTM\$_NONDEFAULT flag was clear) when the calling process had an unended default transaction.
- The DDTM\$_NONDEFAULT flag was clear and a call to \$SET_DEFAULT_TRANS by the calling process was in progress.

SS\$_BADPARAM

Either the DDTM\$_NONDEFAULT flag was set and the *tid* argument was omitted, or the options flags were invalid.

SS\$_CURTIDCHANGE

The DDTM\$_NONDEFAULT flag was clear and a call to change the default transaction of the calling process was in progress.

SS\$_EXASTLM

The process AST limit (ASTLM) was exceeded.

SS\$_EXQUOTA

The job buffered I/O byte limit quota (BYTLM) was exceeded.

SS\$_ILLEFC

The event flag number was invalid.

SS\$_INSFARGS

A required argument was missing.

SS\$_INSFMEM

There was insufficient system dynamic memory for the operation.

SS\$_INVBUFLN

The string passed to the *tx_class* argument was longer than 31 characters.

SS\$_NOLOG

The local node did not have a transaction log.

SS\$_TPDISABLED

The TP_SERVER process was not running on the local node.

\$START_TRANSW

Start Transaction and Wait — Starts a new transaction. \$START_TRANSW always waits for the request to complete before returning to the caller. Other than this, it is identical to \$START_TRANS.

Format

```
SYS$START_TRANSW  
    [efn] , [flags] , iosb [, [astadr] , [astprm] , [tid] , [timeout] , [acmode]]
```

C Prototype

```
int sys$start_transw  
    (unsigned int efn, unsigned int flags, struct _iosb *iosb,...);
```

\$STOP_ALIGN_FAULT_REPORT (Alpha and Integrity servers)

Stop Alignment Fault Reporting — On Alpha and Integrity server systems, disables user image alignment fault reporting.

Format

```
SYS$STOP_ALIGN_FAULT_REPORT
```

C Prototype

```
int sys$stop_align_fault_report (void);
```

Arguments

None

Description

The Stop Alignment Fault Reporting service disables user image alignment fault reporting.

The service returns `SS$_AFR_NOT_ENABLED` if user image alignment fault reporting is not enabled. Otherwise, it returns success.

Required Access or Privileges

None

Required Quota

None

Related Services

```
$GET_ALIGN_FAULT_DATA, $GET_SYS_ALIGN_FAULT_DATA,  
$INIT_SYS_ALIGN_FAULT_REPORT, $PERM_DIS_ALIGN_FAULT_REPORT,  
$PERM_REPORT_ALIGN_FAULT, $START_ALIGN_FAULT_REPORT,  
$STOP_SYS_ALIGN_FAULT_REPORT
```

Condition Values Returned

SS\$_NORMAL

The service completed successfully.

SS\$_AFR_NOT_ENABLED

The \$START_ALIGN_FAULT_REPORT service has not been called.

\$STOP_SYS_ALIGN_FAULT_REPORT (Alpha and Integrity servers)

Stop System Alignment Fault Reporting — On Alpha and Integrity server systems, disables systemwide alignment fault reporting.

Format

```
SYSS$STOP_SYS_ALIGN_FAULT_REPORT
```

C Prototype

```
int sys$stop_sys_align_fault_report (void);
```

Arguments

None

Description

The Stop System Alignment Fault Reporting service disables systemwide alignment fault reporting.

The service returns SS\$_AFR_NOT_ENABLED if systemwide alignment fault reporting is not enabled. Otherwise, it returns success.

Required Access or Privileges

CMKRNL privilege is required.

Required Quota

None

Related Services

\$GET_ALIGN_FAULT_DATA, \$GET_SYS_ALIGN_FAULT_DATA,
\$INIT_SYS_ALIGN_FAULT_REPORT, \$PERM_DIS_ALIGN_FAULT_REPORT,
\$PERM_REPORT_ALIGN_FAULT, \$START_ALIGN_FAULT_REPORT

Condition Values Returned

SS\$_NORMAL

The service completed successfully.

SS\$_NOPRIV

The caller lacks sufficient privilege.

SS\$_AFR_NOT_ENABLED

The \$START_ALIGN_FAULT_REPORT service has not been called.

\$SUBSYSTEM

Subsystem — Saves or restores the process image rights for the current protected subsystem.

Format

```
SYS$SUBSYSTEM enbflg
```

C Prototype

```
int sys$subsystem (unsigned int enbflg);
```

Argument

enbflg

OpenVMS usage: boolean
type: longword (unsigned)
access: read only
mechanism: by value

Value specifying whether the protected subsystem identifiers are to be saved or restored. If the *enbflg* argument is set to 0, the active subsystem is saved. If it is set to 1, the subsystem is restored.

Description

A protected subsystem image is a main image that has in its access control list a special type of ACE that names a set of identifiers and their attributes. Whenever the operating system activates a main image that has protected subsystem identifiers associated with it, these identifiers are automatically granted to the process for the duration of the image.

In essence, a protected subsystem provides the same behavior as if the image had been installed with the identifiers. Subsystem identifiers are sometimes referred to as image rights, in contrast to process rights and system rights.

The Subsystem service provides an easy way for a protected subsystem image to dynamically save and restore its subsystem identifiers. A protected subsystem might choose to turn off its subsystem identifiers

at certain times to temporarily revoke the user's access to the objects comprising the protected subsystem. For example, DCL uses the \$SUBSYSTEM service to temporarily remove any image identifiers from the process during Ctrl/Y interrupt processing.

The image rights are saved in the process control region and automatically deleted on image rundown (\$RMSRUNDOWN).

For more information about protected subsystems, see the *VSI OpenVMS Guide to System Security*.

Required Access or Privileges

None

Required Quota

None

Related Services

None

Condition Values Returned

SS\$_WASCLR

The service completed successfully; protected subsystem had no identifiers associated with it.

SS\$_WASSET

The service completed successfully; protected subsystem had identifiers associated with it.

\$SUSPND

Suspend Process — Allows a process to suspend itself or another process.

Format

```
SYS$SUSPND [pidadr] , [prcnam] , [flags]
```

C Prototype

```
int sys$suspnd (unsigned int *pidadr, void *prcnam, unsigned int flags);
```

Arguments

pidadr

OpenVMS usage:	process_id
type:	longword (unsigned)
access:	modify
mechanism:	by reference

Process identification (PID) of the process to be suspended. The *pidadr* argument is the address of the longword PID. The *pidadr* argument can refer to a process running on the local node or a process running on another node in the OpenVMS Cluster system.

You must specify the *pidadr* argument to suspend a process whose UIC group number is different from that of the calling process.

prcnam

OpenVMS usage: process_name
type: character-coded text string
access: read only
mechanism: by descriptor-fixed-length string descriptor

Name of the process to be suspended. The *prcnam* argument is the address of a character string descriptor pointing to the process name. A process running on the local node can be identified with a 1- to 15-character string. To identify a process on a particular node on a cluster, specify the full process name, which includes the node name as well as the process name. The full process name can contain up to 23 characters.

A process name is implicitly qualified by its UIC group number. Because of this, you can use the *prcnam* argument only to suspend processes in the same UIC group as the calling process.

To suspend processes in other groups, you must specify the *pidadr* argument.

flags

OpenVMS usage: mask_longword
type: longword (unsigned)
access: read only
mechanism: by value

Longword of bit flags specifying options for the suspend operation. Currently, only bit 0 is used for the *flags* argument. When bit 0 is set, the process is suspended at kernel mode and ASTs are not deliverable to the process.

To request a kernel mode suspend, the caller must be in either kernel mode or executive mode. The default (bit 0 is clear) is to suspend the process at supervisor mode, where executive or kernel mode ASTs can be delivered to the process. If executive or kernel mode ASTs have been delivered to a process suspended at supervisor mode, that process will return to its suspended state after the AST routine executes.

Description

The Suspend Process service allows a process to suspend itself or another process.

A suspended process can receive executive or kernel mode ASTs, unless it is suspended at kernel mode. If a process is suspended at kernel mode, the process cannot receive any ASTs or otherwise be executed until another process resumes or deletes it. If you specify neither the *pidadr* nor the *prcnam* argument, the caller process is suspended.

If the longword value at address *pidadr* is 0, the PID of the target process is returned.

The `$$SUSPND` service requires system dynamic memory.

The `$$SUSPND` service completes successfully if the target process is already suspended.

Unless it has pages locked in the balance set, a suspended process can be removed from the balance set to allow other processes to execute.

Note that a kernel mode suspend request can override a supervisor mode suspend state, but a supervisor suspend request cannot override a kernel mode suspend state.

The Resume Process (`$RESUME`) service allows a suspended process to continue. If one or more resume requests are issued for a process that is not suspended, a subsequent suspend request completes immediately; that is, the process is not suspended. No count is maintained of outstanding resume requests.

Note

When the `$$SUSPND` service is called and the target process is on a different cluster node than that of the process calling the `$$SUSPND` service, the kernel mode suspend flag (bit 0) is ignored. As a result, any suspend is treated as a supervisor-mode suspend.

Required Access or Privileges

Depending on the operation, the calling process might need one of the following privileges to use `$$SUSPND`:

- `GROUP` privilege to suspend another process in the same group, unless the process to be suspended has the same UIC as the calling process
- `WORLD` privilege to suspend any other process in the system

Required Quota

None

Related Services

`$SCANEXH`, `$CREPRC`, `$DCLEXH`, `$DELPRC`, `$EXIT`, `$FORCEX`, `$GETJPI`, `$GETJPIW`, `$HIBER`, `$PROCESS_SCAN`, `$RESUME`, `$SETPRI`, `$SETPRN`, `$SETPRV`, `$SETRWM`, `$WAKE`

Condition Values Returned

`SS$_NORMAL`

The service completed successfully.

`SS$_ACCVIO`

The process name string or string descriptor cannot be read by the caller, or the process identification cannot be written by the caller.

`SS$_INCOMPAT`

The remote node is running an incompatible version of the operating system.

SS\$_INSFMEM

The system dynamic memory is insufficient for completing the service.

SS\$_IVLOGNAM

The specified process name has a length of 0 or has more than 15 characters.

SS\$_NONEXPR

The specified process does not exist, or an invalid process identification was specified.

SS\$_NOPRIV

The target process was not created by the caller and the calling process does not have GROUP or WORLD privilege, or flag bit 0 was set from outer mode.

SS\$_NOSUCHNODE

The process name refers to a node that is not currently recognized as part of the OpenVMS Cluster system.

SS\$_NOSUSPEND

The process was previously marked as not suspendable by the PCB\$_NOSUSPEND flag.

SS\$_REMRSRC

The remote node has insufficient resources to respond to the request. (Bring this error to the attention of your system manager.)

SS\$_UNREACHABLE

The remote node is a member of the cluster but is not accepting requests. (This is normal for a brief period early in the system boot process.)

SS\$_WAIT_CALLERS_MODE

Bit 1 was used in the *flags* argument.

\$SYNCH

Synchronize — Checks the completion status of a system service that completes asynchronously. On Alpha and Integrity server systems, this service accepts 64-bit addresses.

Format

```
SYS$SYNCH [efn] , [iosb]
```

C Prototype

```
int sys$synch (unsigned int efn, struct _iosb *iosb);
```

Arguments

efn

OpenVMS usage: `ef_number`
type: longword (unsigned)
access: read only
mechanism: by value

Number of the event flag specified in the call to the system service whose completion status is to be checked by `$$SYNCH`. The *efn* argument is a longword containing this number; however, `$$SYNCH` uses only the low-order byte.

iosb

OpenVMS usage: `io_status_block`
type: quadword (unsigned)
access: read only
mechanism: by 32- or 64-bit reference (Alpha and Integrity servers)

I/O status block specified in the call to the system service whose completion status is to be checked by `$$SYNCH`. The *iosb* argument is the address of this quadword I/O status block.

Description

The Synchronize service checks the completion status of a system service that completes asynchronously. The service whose completion status is to be checked must have been called with the *efn* and *iosb* arguments specified, because the `$$SYNCH` service uses the event flag and I/O status block of the service to be checked.

This service performs a true test for the completion of an asynchronous service, such as `$GETJPI`. `$$SYNCH` operates in the following way:

1. When called, `$$SYNCH` waits (by calling `$WAITFR`) for the event flag to be set.
2. When the event flag is set, `$$SYNCH` checks to see whether the I/O status block is nonzero. If it is nonzero, then the asynchronous service has completed, and `$$SYNCH` returns to the caller.
3. If the I/O status block is the value 0, then the asynchronous service has not yet completed and the event flag was set by the completion of an event not associated with the completion of `$GETJPI`. In this case, `$$SYNCH` clears the event flag (by calling `$CLREF`) and waits again (by calling `$WAITFR`) for the event flag to be set, repeating this cycle until the I/O status block is nonzero.

The `$$SYNCH` service always sets the specified event flag when it returns to the caller. This ensures that different program segments can use the same event flag without conflicting. For example, assume that calls to `$GETJPI` and `$GETSYI` both specify the same event flag and that `$$SYNCH` is called to check for the completion of `$GETJPI`. If `$GETSYI` sets the event flag, `$$SYNCH` clears the flag and waits for `$GETJPI` to set it. When `$GETJPI` sets the flag, `$$SYNCH` returns to the caller and sets the event flag. In this way, the flag set by `$GETSYI` is not lost, and another call to `$$SYNCH` will show the completion of `$GETSYI`.

The `$$SYNCH` service is useful when a program calls an asynchronous service but must perform some other work before testing for the completion of the asynchronous service. In this case, the program should call `$$SYNCH` at that point when it must know that the service has completed and when it is willing to wait for the service to actually complete.

When a program calls an asynchronous service (for example, \$QIO) and actually waits in line (by calling \$WAITFR) for its completion without performing any other work, you could improve that program by calling the synchronous form of that service (for example, \$QIOW). The synchronous services such as \$QIOW execute code that checks for the true completion status in the same way that \$SYNCH does.

Required Access or Privileges

None

Required Quota

None

Condition Values Returned

SS\$_NORMAL

The service completed successfully. The asynchronous service has completed, and the I/O status block contains the condition value describing the completion status of the asynchronous service.

SS\$_ACCVIO

The I/O status block cannot be read by the caller.

SS\$_ILLEFC

An illegal event flag was specified.

SS\$_UNASEFC

The process is not associated with the cluster containing the specified event flag.

\$TIMCON

Time Converter — Converts 128-bit Coordinated Universal Time (UTC) format to 64-bit system format or 64-bit system format to 128-bit UTC format based on the value of the convert flag. On Alpha and Integrity server systems, this service accepts 64-bit addresses.

Format

```
SYS$TIMCON [smnadr] , [utcadr] , cvtflg
```

C Prototype

```
int sys$timcon
    (struct _generic_64 *smnadr, unsigned int *utcadr [4],
     unsigned long int cvtflg);
```

Arguments

smnadr

OpenVMS usage: `date_time`
type: `quadword (unsigned)`
access: `read/write`
mechanism: `by 32- or 64-bit reference (Alpha and Integrity servers)`

The 64-bit system format value that \$TIMCON will use in the conversion. The *smnadr* argument will be read from or written to based on the value of the *cvtflg* argument. The *smnadr* is required when converting UTC time to 64-bit system format.

utcadr

OpenVMS usage: `coordinated universal time`
type: `utc_date_time`
access: `read/write`
mechanism: `by 32- or 64-bit reference (Alpha and Integrity servers)`

UTC time value that \$TIMCON will use in the conversion. The *utcadr* argument will be read from or written to based on the value of the *cvtflg* argument. The *utcadr* argument is required when converting 64-bit system format to UTC time.

cvtflg

OpenVMS usage: `conversion flag`
type: `longword (unsigned)`
access: `read only`
mechanism: `by value`

A longword indicating the direction of the conversion. If the *cvtflg* value is 0, UTC time is converted to 64-bit system value. If the *cvtflg* value is 1, 64-bit system format is converted to UTC time.

Description

The Time Converter service converts 64-bit system format time to UTC format, and vice versa.

When converting a 64-bit system format time to 128-bit UTC format time, the time zone of the local system is used.

When converting a 128-bit UTC format time to a 64-bit system time, the time zone differential factor encoded in the 128-bit buffer is used.

Condition Values Returned

SS\$_NORMAL

The service completed successfully.

SS\$_INVTIME

The input time cannot be converted because its value is out of the legal range or is a delta time, or the UTC is of an illegal format.

\$TRANS_EVENT

Transaction Event — Forces a transaction state change for a transaction in which there is at least one RM participant that has set the DDTM\$M_COORDINATOR flag.

Format

```
SYS$TRANS_EVENT
    [efn] , [flags] , iosb , [astadr] , [astprm] , tid , rm_id , tx_event
```

C Prototype

```
int sys$trans_event
    (unsigned int efn, unsigned int flags, struct _iosb *iosb,
     void (*astadr)(__unknown_params), int astprm, unsigned int tid [4],
     unsigned int rm_id, unsigned int tx_event);
```

Arguments

efn

OpenVMS usage: ef_number
type: longword (unsigned)
access: read only
mechanism: by value

Number of the event flag that is set when the service completes. If this argument is omitted, event flag 0 is used.

flags

OpenVMS usage: mask_longword
type: longword (unsigned)
access: read only
mechanism: by value

Reserved to OpenVMS. This argument must be zero.

iosb

OpenVMS usage: io_status_block
type: quadword (unsigned)
access: write only
mechanism: by reference

The I/O status block in which the completion status of the service is returned as a condition value. See the Condition Values Returned section.

The outcome of the state change is indicated by the contents of the I/O status block.

The following diagram shows the structure of the I/O status block:

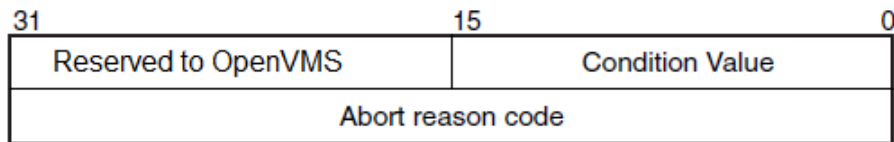

VM-0779A-AI

astadr

OpenVMS usage: ast_procedure
 type: procedure entry mask
 access: call without stack unwinding
 mechanism: by reference

The AST routine that is executed when the service completes, if SS\$_NORMAL is returned in R0. The *astadr* argument is the address of the entry mask of this routine. The routine is executed in the same access mode as that of the caller of the \$TRANS_EVENT service.

astprm

OpenVMS usage: user_arg
 type: longword (unsigned)
 access: read only
 mechanism: by value

The AST parameter passed to the AST routine specified by the *astadr* argument.

tid

OpenVMS usage: trans_id
 type: octaword (unsigned)
 access: read only
 mechanism: by reference

The identifier (TID) of transaction to which the state change is to be applied.

rm_id

OpenVMS usage: identifier
 type: longword (unsigned)
 access: read only
 mechanism: by value

The identifier of the Resource Manager identifier (RMI) with which the coordinating Resource Manager (RM) participant is associated.

tx_event

OpenVMS usage: identifier
 type: longword (unsigned)

access: read only
 mechanism: by value

The operation to be performed on the transaction. The permitted values and the possible successful outcomes are listed in Table 15.

Description

The \$TRANS_EVENT system service is used by coordinating RM participants to change the state of transactions.

Preconditions for the successful completion of \$TRANS_EVENT include:

- The caller must have the SYSPRV privilege or be in either executive or kernel mode.
- The RM participant must have set the DDTM\$M_COORDINATOR flag on the call to \$JOIN_RM. Coordinating resource managers cannot join the transaction by calling \$ACK_EVENT.
- The access mode of the caller must be the same as or more privileged than that of the transaction within the process.

Table 15. Completion Semantics of the \$TRANS_EVENT Service

Operation	Completion Semantics
DDTM\$K_TX_PREPARE	<p>A vote has been received from each RM participant and synchronized branch.</p> <p>The status code returned is the combination of the individual votes. The possible values are:</p> <ul style="list-style-type: none"> • SS\$_PREPARED. All participants are ready to commit the transaction. Thus all RM participants voted "yes" and all synchronized branches called \$END_BRANCH. Note that a read-only vote from an RM participant is counted as a "yes" vote but this response is not returned if all RM participants voted read-only. Unsynchronized branches are assumed to be willing to commit. A further operation (commit or abort) is necessary to complete the transaction. • SS\$_FORGET. All participants are ready to permit the transaction to be committed but do not require any further notification of transaction events. Thus no further \$TRANS_EVENT calls are required for this transaction. Possible reasons for this response are: <ul style="list-style-type: none"> • All RM participants voted read-only. • The specified transaction (TID) did not exist. • The specified transaction was already prepared (Cyclic graph). • SS\$_VETO. The transaction cannot be committed. No further \$TRANS_EVENT calls are required for this transaction. One

	reason why the transaction cannot commit, an abort reason code, is placed in the second longword of the <i>iosb</i> argument.
DDTM\$K_TX_COMMIT	The only status code returned on successful completion is SS\$_FORGET. Sufficient information has been hardened by the DECdtm transaction manager to commit the transaction.
DDTM\$K_TX_ABORT	The only status code returned on successful completion is SS\$_FORGET. Abort processing has been initiated.

Required Privileges

SYSPRV is required unless the caller is in executive or kernel mode.

Required Quotas

None

Related Services

\$ABORT_TRANS, \$ABORT_TRANSW, \$ACK_EVENT, \$ADD_BRANCH, \$ADD_BRANCHW, \$CREATE_UID, \$DECLARE_RM, \$DECLARE_RMW, \$END_BRANCH, \$END_BRANCHW, \$END_TRANS, \$END_TRANSW, \$FORGET_RM, \$FORGET_RMW, \$GETDTI, \$GETDTIW, \$GET_DEFAULT_TRANS, \$JOIN_RM, \$JOIN_RMW, \$SETDTI, \$SETDTIW, \$SET_DEFAULT_TRANS, \$SET_DEFAULT_TRANSW, \$START_BRANCH, \$START_BRANCHW, \$START_TRANS, \$START_TRANSW, \$TRANS_EVENTW

Condition Values Returned

SS\$_NORMAL

The request was successfully queued. This value is only returned in R0.

SS\$_ACCVIO

An argument was not accessible to the caller.

SS\$_BADPARAM

Invalid value for *tx_event* parameter.

SS\$_EXASTLM

The process AST limit (ASTLM) was exceeded.

SS\$_FORGET

No further \$TRANS_EVENT calls are required for this transaction.

- If *tx_event* = DDTM\$K_TX_ABORT, then abort processing has been initiated.
- If *tx_event* = DDTM\$K_TX_COMMIT, then sufficient information has been hardened to commit the transaction.
- If *tx_event* = DDTM\$K_TX_PREPARE, then one of the following has occurred:
 - All participants voted read-only.

- The *tid* was not known.
- The *rm_id* was not known.

SS\$_ILLEFC

The event flag number was invalid.

SS\$_INSFARGS

A required argument was missing.

SS\$_INSFMEM

There was insufficient system dynamic memory for the operation.

SS\$_NOLOG

The local node did not have a transaction log.

SS\$_NOPRIV

The specified *rm_id* was not a coordinator of the specified transaction.

SS\$_NOSYSPRV

The caller is in user or supervisor mode but did not have SYSPRV set.

SS\$_PREPARED

All participants are ready to commit the transaction. A further operation (commit or abort) is necessary to complete the transaction.

SS\$_TPDISABLED

The TP_SERVER process was not running on the local node.

SS\$_VETO

The *tx_event* parameter contains the value DDTM\$K_TX_PREPARE, and DECdtm or a participant was not in a position to accept an order to commit. One reason why the transaction must abort is supplied in the abort reason code field of the IOSB. No further call to \$TRANS_EVENT is needed for a transaction when this condition code is returned.

SS\$_WRONGACMODE

The access mode of the caller was less privileged than that of a branch of the transaction in this process.

SS\$_WRONGSTATE

The transaction was in the wrong state for the attempted operation:

- Commit operation when transaction is not prepared.
- Any operation while another call is in progress.

\$TRANS_EVENTW

Transaction Event and Wait — Forces a transaction state change for a transaction in which there is at least one RM participant that has specified the DDTM\$M_COORDINATOR flag.

\$TRANS_EVENTW always waits for the request to complete before returning to the caller. Other than this, it is identical to \$TRANS_EVENT.

Format

```
SYS$TRANS_EVENTW
    [efn] , [flags] , iosb , [astadr] , [astprm], tid , rm_id , tx_event
```

C Prototype

```
int sys$trans_eventw
    (unsigned int efn, unsigned int flags, struct _iosb *iosb,
     void (*astadr)(__unknown_params), __int64 astprm, )
```

\$TRNLNM

Translate Logical Name — Returns information about a logical name. On Alpha and Integrity server systems, this service accepts 64-bit addresses.

Format

```
SYS$TRNLNM [attr] , tabnam , lognam , [acmode] , [itmlst]
```

C Prototype

```
int sys$trnlnm
    (unsigned int *attr, void *tabnam, void *lognam,
     unsigned char *acmode, void *itmlst);
```

Arguments

attr

OpenVMS usage:	mask_longword
type:	longword (unsigned)
access:	read only
mechanism:	by 32- or 64-bit reference (Alpha and Integrity servers)

Attributes controlling the search for the logical name. The **attr** argument is the 32- or 64-bit address (on Alpha and Integrity server systems) of a longword bit mask specifying these attributes.

Each bit in the longword corresponds to an attribute and has a symbolic name. The \$LNMDEF macro defines these symbolic names. To specify an attribute, use its symbolic name or set its corresponding bit. All undefined bits in the longword have the value 0.

If you do not specify this argument or specify it as the value 0 (no bits set), the following attributes are not used:

Attribute	Description
LNMSM_CASE_BLIND	If set, \$TRNLNM does not distinguish between uppercase and lowercase letters in the logical name to be translated.
LNMSM_INTERLOCKED	If set, \$TRNLNM does not translate the current logical name until any clusterwide logical name modifications in progress are completed. This attribute is not set by default. If your application requires translation using the most recent definition of a clusterwide logical name, use this attribute to ensure that the translation is stalled until all pending modifications have been made.

tabnam

OpenVMS usage: logical_name
 type: character-coded text string
 access: read only
 mechanism: by 32- or 64-bit descriptor–fixed-length string descriptor (Alpha and Integrity servers)

Name of the logical name table or the name of a searchlist logical name that translates the name of one or more tables in which to search for the specified logical name. The *tabnam* argument is the 32- or 64-bit address (on Alpha and Integrity server systems) of a descriptor pointing to this name. This argument is required.

The name must be entered in uppercase letters. (This requirement differs from the \$CRELNT system service, which automatically changes *tabnam* to uppercase.)

If the table name is not the name of a logical name table, it is assumed to be a logical name and is translated iteratively until either the name of a logical name table is found or the number of translations allowed by the system have been performed. If the table name translates to a list of logical name tables, the tables are searched in the specified order.

lognam

OpenVMS usage: logical_name
 type: character-coded text string
 access: read only
 mechanism: by 32- or 64-bit descriptor–fixed-length string descriptor (Alpha and Integrity servers)

Logical name about which information is to be returned. The *lognam* argument is the 32- or 64-bit address (on Alpha and Integrity server systems) of a descriptor pointing to the logical name string. This argument is required.

acmode

OpenVMS usage: access_mode
 type: byte (unsigned)
 access: read only
 mechanism: by 32- or 64-bit reference (Alpha and Integrity servers)

Access mode to be used in the translation. The *acmode* argument is the 32- or 64-bit address (on Alpha and Integrity server systems) of a byte specifying the access mode. The \$PSLDEF macro defines symbolic names for the four access modes.

When you specify the *acmode* argument, \$TRNLNM ignores all names (both logical names and table names) at access modes less privileged than the specified access mode. The specified access mode is not checked against that of the caller.

If you do not specify *acmode*, \$TRNLNM performs the translation without regard to access mode; however, the translation process proceeds from the outermost to the innermost access modes. Thus, if two logical names with the same name but at different access modes exist in the same table, \$TRNLNM translates the name with the outermost access mode.

itmlst

OpenVMS usage: 32-bit *item_list_3* or 64-bit *item_list_64b*
 type: longword (unsigned) for 32-bit; quadword (unsigned) for 64-bit
 access: read only
 mechanism: by 32- or 64-bit reference (Alpha and Integrity servers)

tem list describing the information that \$TRNLNM is to return. The *itmlst* argument is the 32- or 64-bit address (on Alpha and Integrity server systems) of a list of item descriptors, each of which specifies or controls an item of information to be returned. An item list in 32-bit format is terminated by a longword of 0; an item list in 64-bit format is terminated by a quadword of 0. All items in an item list must be of the same format—either 32-bit or 64-bit.

The following diagram depicts the 32-bit format of a single item descriptor:

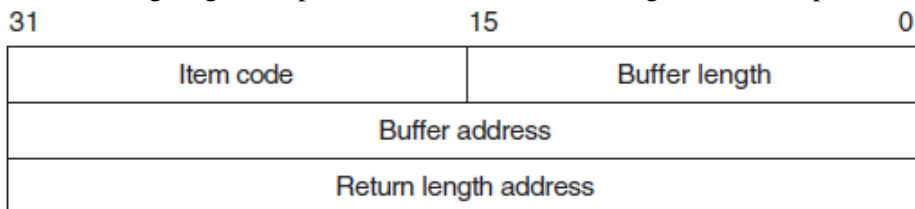

ZK-5186A-GE

The following table defines the item descriptor fields for 32-bit item list entries:

Descriptor Field	Definition
Buffer length	A word specifying the number of bytes in the buffer pointed to by the buffer address field.
Item code	A word containing a symbolic code describing the nature of the information currently in the buffer, to be returned in the buffer, or to be returned by the buffer pointed to by the buffer address field.
Buffer address	A longword containing the 32-bit address of the buffer that specifies or receives the information.
Return length address	A longword containing the 32-bit address of a word specifying the actual length (in bytes) of the information returned by \$TRNLNM in the buffer pointed to by the buffer address field.

The following diagram depicts the 64-bit format of a single item descriptor:

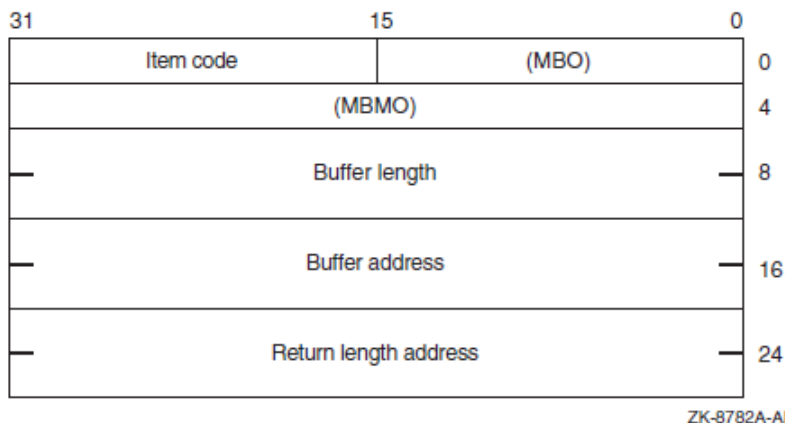

The following table defines the item descriptor fields for 64-bit item list entries:

Descriptor Field	Definition
MBO	The field must contain a 1. The MBO and MBMO fields are used to distinguish 32-bit and 64-bit item list entries.
Item code	A word containing a symbolic code describing the nature of the information currently in the buffer, to be returned in the buffer, or to be returned by the buffer pointed to by the buffer address field.
MBMO	The field must contain a -1. The MBMO and MBO fields are used to distinguish 32-bit and 64-bit item list entries.
Buffer address	A quadword containing the 64-bit address of the buffer that specifies or receives the information.
Return length address	A quadword containing the 64-bit address of a word specifying the actual length (in bytes) of the information returned by \$TRNLNM in the buffer pointed to by the buffer address field.

Item Codes

LNMS\$_ACMODE

Returns the access mode that was associated with the logical name at the time of its creation. The buffer address field in the item descriptor is the address of a byte in which \$TRNLNM writes the access mode.

LNMS\$_ATTRIBUTES

Returns the attributes of the logical name and the equivalence name associated with the current LNMS\$_INDEX value.

The buffer address field of the item descriptor points to a longword bit mask wherein each bit corresponds to an attribute. The \$TRNLNM service sets the corresponding bit for each attribute possessed by either the logical name or the equivalence name.

The \$LNMSDEF macro defines the following symbolic names for these attributes:

Attribute	Description
LNMSM_CONCEALED	If \$TRNLNM sets this bit, the equivalence name at the current index value for the logical name is a concealed logical name, as interpreted by OpenVMS RMS.

Attribute	Description
LNMSM_CONFINE	If \$TRNLNM sets this bit, the logical name is not copied from a process to any of its spawned subprocesses. The DCL command SPAWN creates subprocesses.
LNMSM_CRELOG	If \$TRNLNM sets this bit, the logical name was created using the \$CRELOG system service.
LNMSM_EXISTS	If \$TRNLNM sets this bit, an equivalence name with the specified index does exist.
LNMSM_NO_ALIAS	If \$TRNLNM sets this bit, the name of the logical name cannot be given to another logical name defined in the same table at an outer access mode.
LNMSM_TABLE	If \$TRNLNM sets this bit, the logical name is the name of a logical name table.
LNMSM_CLUSTERWIDE	If \$TRNLNM sets this bit, the logical name is in a clusterwide table.
LNMSM_TERMINAL	If \$TRNLNM sets this bit, the equivalence name for the logical name cannot be subjected to further (recursive) logical name translation.

LNMS_CHAIN

Processes another item list immediately following the current item list. The LNMS_CHAIN item code must be the last one in the current item list. The buffer address field of the item descriptor points to the next item list.

You can chain together 32-bit and 64-bit item lists.

LNMS_INDEX

Searches for an equivalence name that has the specified index value. The buffer address field of the item descriptor points to a longword containing a user-specified integer in the range 0 to 127.

If you do not specify this item code, the implied value of LNMS_INDEX is 0 and \$TRNLNM returns information about the equivalence name at index 0.

Because a logical name can have more than one equivalence name and each equivalence name is identified by an index value, you should specify the LNMS_INDEX item code first in the item list, before specifying LNMS_STRING, LNMS_LENGTH, or LNMS_ATTRIBUTES. These item codes return information about the equivalence name identified by the current index value, LNMS_INDEX.

LNMS_LENGTH

Returns the length of the equivalence name string corresponding to the current LNMS_INDEX value. The buffer address field in the item descriptor is the address of the longword in which \$TRNLNM writes this length.

If an equivalence name does not exist at the current LNMS_INDEX value, \$TRNLNM returns the value 0 to the longword pointed to by the return length field of the item descriptor.

LNMS_MAX_INDEX

Each equivalence name for the logical name has an index associated with it. When you specify LNMS_MAX_INDEX, \$TRNLNM returns a value equal to the largest equivalence name index. The buffer address field in the item descriptor is the address of a longword in which \$TRNLNM writes

this value. If the logical name exists but has no equivalence name (and, therefore, no index value), \$STRNLNM returns a value of -1.

LNMS_STRING

Returns the equivalence name string corresponding to the current LNMS_INDEX value. The buffer address field of the item descriptor points to a buffer containing this string. The return length address field of the item descriptor contains an address of a word that contains the length of this string in bytes. The maximum length of the equivalence name string is 255 characters.

If an equivalence name does not exist at the current LNMS_INDEX value, \$STRNLNM returns the value 0 in the return length address field of the item descriptor.

LNMS_TABLE

Returns the name of the table containing the logical name being translated. The buffer address field of the item descriptor points to the buffer in which \$STRNLNM returns this name. The return length address field of the item descriptor specifies the address of a word in which \$STRNLNM writes the size of the table name. The maximum length of the table name is 31 characters.

Description

The Translate Logical Name service returns information about a logical name. You need read access to a shareable logical name table to translate a logical name located in that shareable logical name table.

For conventions regarding logical names for process-permanent files, see the chapter "Logical Name Services" in the *VSI OpenVMS Programming Concepts Manual*.

Required Access or Privileges

Read access is required.

Required Quota

None

Related Services

\$ADJSTK, \$ADJWSL, \$CRELNM, \$CRELNT, \$CRETVA, \$CRMPSC, \$DELLNM, \$DELTVA, \$DGBLSC, \$EXPREG, \$LCKPAG, \$LKWSET, \$MGBLSC, \$PURGWS, \$SETPRT, \$SETSTK, \$SETSWM, \$ULWSET, \$UPDSEC, \$UPDSECW

Condition Values Returned

SS\$_NORMAL

The service completed successfully. An equivalence name for the logical name has been found.

SS\$_ACCVIO

The service cannot access the location or locations specified by one or more arguments.

SS\$_BADPARAM

One or more arguments have an invalid value, or a logical name table name or logical name was not specified. Or, an item list containing both 32-bit and 64-bit item list entries was found.

SS\$_BUFFEROVF

The service completed successfully. The buffer length field in an item descriptor specified an insufficient value, so the buffer was not large enough to hold the requested data.

SS\$_IVLOGNAM

The *tabnam* argument or *lognam* argument specifies a string whose length is not in the required range of 1 through 255 characters.

SS\$_IVLOGTAB

The *tabnam* argument does not specify a logical name table.

SS\$_NOLOGNAM

The logical name was not found in the specified logical name table or tables.

SS\$_NOPRIV

The caller lacks the necessary privilege to access the specified name.

SS\$_TOOMANYLNAM

Logical name translation of the table name exceeded the allowable depth (10 translations).

\$TRUNCATE

Shortens Sequential File — The Truncate service shortens a sequential file. For additional information about this service, see the *VSI OpenVMS Record Management Services Reference Manual*.

\$TSTCLUEVT

Test Cluster Event — Simulates the occurrence of a cluster configuration event to test the functionality of the notification AST.

Format

```
SYS$TSTCLUEVT [handle] , [acmode] , [event]
```

C Prototype

```
int sys$tstcluevt  
    (unsigned int *handle, unsigned int acmode, unsigned int event);
```

Arguments

handle

OpenVMS usage: identifier

type: quadword (unsigned)
 access: read only
 mechanism: by reference

Identification of the asynchronous system trap (AST) to be tested. The *handle* argument uniquely identifies the request and is returned when the \$SETCLUEVT service is called.

acmode

OpenVMS usage: access_mode
 type: longword (unsigned)
 access: read only
 mechanism: by value

Access mode for which a configuration event AST is to be triggered. The *acmode* argument is a longword containing the access mode.

Each access mode has a symbolic name. The \$PSLDEF macro defines the following symbols for the four access modes.

Symbol	Access Mode
PSL\$C_KERNEL	Kernel
PSL\$C_EXEC	Executive
PSL\$C_SUPER	Supervisor
PSL\$C_USER	User

event

OpenVMS usage: event_code
 type: longword (unsigned)
 access: read only
 mechanism: by value

Event code indicating the type of configuration for which an AST is to be triggered.

Each event type has a symbolic name. The \$CLUEVTDEF macro defines the following symbolic names.

Symbolic Name	Description
CLUEVT\$C_ADD	One or more OpenVMS nodes have been added to the OpenVMS Cluster system.
CLUEVT\$C_REMOVE	One or more OpenVMS nodes have been removed from the OpenVMS Cluster system.

Description

The Test Cluster Event service simulates the occurrence of a cluster configuration event to test the functionality of the notification ASTs. The service allows an application to test itself and must be issued from within the same process as the application being tested. \$TSTCLUEVT does not affect other processes in the cluster.

The service will allow one specific AST to be fired via the *handle* argument, or all ASTs for a specific configuration event via the *event* argument. Specifying both the *event* and the *handle* arguments will return an error.

If the *handle* argument is specified, the value of the *acmode* argument must not be greater than the access mode of the caller and must match the mode specified when the \$SETCLUEVT service was called.

If the *event* argument is specified, those ASTs that match the value specified in the *acmode* argument, or that match the caller's mode, will be triggered.

Required Access or Privileges

None

Required Quota

None

Related Services

\$CLRCLUEVT, \$SETCLUEVT

Condition Values Returned

SS\$_NORMAL

The service completed successfully.

SS\$_BADPARAM

There is an unsatisfactory combination of event and handle parameters, or the event was specified incorrectly.

SS\$_NOSUCHOBJ

No request was found that matches the description supplied.

\$ULKPAG

Unlock Pages from Memory — Unlocks pages that were previously locked in memory by the Lock Pages in Memory (\$LCKPAG) service. Locked pages are automatically unlocked and deleted at image exit.

Format

```
SYS$ULKPAG inadr , [retadr] , [acmode]
```

C Prototype

```
int sys$sulcpag
    (struct _va_range *inadr, struct _va_range *retadr, unsigned int
    acmode);
```

Arguments

inadr

OpenVMS usage: address_range
type: longword (unsigned)
access: read only
mechanism: by reference

Starting and ending virtual addresses of the pages to be unlocked. The *inadr* argument is the address of a 2-longword array containing, in order, the starting and ending process virtual addresses. Only the virtual page number portion of each virtual address is used; the low-order byte-within-page bits are ignored. If the starting and ending virtual addresses are the same, a single page is unlocked.

If more than one page is being unlocked and you need to determine specifically which pages had been previously unlocked, you should unlock the pages one at a time, that is, one page per call to \$ULKPAG. The condition value returned by \$ULKPAG indicates whether the page was previously unlocked.

retadr

OpenVMS usage: address_range
type: longword (unsigned)
access: write only
mechanism: by reference—array reference or descriptor

Starting and ending process virtual addresses of the pages actually unlocked by \$ULKPAG. The *retadr* argument is the address of a 2-longword array containing, in order, the starting and ending process virtual addresses.

If an error occurs while multiple pages are being unlocked, *retadr* specifies those pages that were successfully unlocked before the error occurred. If no pages were successfully unlocked, both longwords in the *retadr* array contain the value -1.

acmode

OpenVMS usage: access_mode
type: longword (unsigned)
access: read only
mechanism: by value

Access mode on behalf of which the request is being made. The *acmode* argument is a longword containing the access mode. The \$PSLDEF macro defines the symbols for the four access modes.

The most privileged access mode used is the access mode of the caller. To unlock any specified page, the resultant access mode must be equal to or more privileged than the access mode of the owner of that page.

Description

The Unlock Pages from Memory service unlocks pages that were previously locked in memory by the Lock Pages in Memory (\$LCKPAG) service. Locked pages are automatically unlocked and deleted at image exit.

On Alpha and Integrity server systems, if you are attempting to unlock executable code, you should issue multiple \$ULKPAG calls: one to unlock the code pages and others to unlock the linkage section references to these pages.

Required Access or Privileges

To call the \$ULKPAG service, a process must have PSWAPM privilege.

Required Quota

None

Related Services

For more information, see the chapter on memory management in the *VSI OpenVMS Programming Concepts Manual*.

Condition Values Returned

SS\$_WASCLR

The service completed successfully. At least one of the specified pages was previously unlocked.

SS\$_WASSET

The service completed successfully. All of the specified pages were previously locked.

SS\$_ACCVIO

The input array cannot be read by the caller; the output array cannot be written by the caller; or a page in the specified range is inaccessible or does not exist.

\$ULKPAG_64 (Alpha and Integrity servers)

Unlock Pages from Memory — On Alpha and Integrity server systems, unlocks pages that were previously locked in memory by the Lock Pages in Memory (\$LCKPAG_64) service. This service accepts 64-bit addresses.

Format

```
SYS$ULKPAG_64
    start_va_64 , length_64 , acmode , return_va_64 , return_length_64
```

C Prototype

```
int sys$ulkpag_64
    (void *start_va_64, unsigned __int64 length_64, unsigned int acmode,
     void *(*return_va_64), unsigned __int64 *return_length_64);
```

Arguments

start_va_64

OpenVMS usage: address
type: quadword address
access: read only
mechanism: by value

The starting virtual address of the pages to be unlocked. The specified virtual address will be rounded down to a CPU-specific page boundary.

length_64

OpenVMS usage: byte count
type: quadword (unsigned)
access: read only
mechanism: by value

Length of the virtual address space to be unlocked. The specified length will be rounded up to a CPU-specific page boundary so that it includes all CPU-specific pages in the requested range.

acmode

OpenVMS usage: access_mode
type: longword (unsigned)
access: read only
mechanism: by value

Access mode on behalf of which the request is being made. The *acmode* argument is a longword containing the access mode.

The \$PSLDEF macro in STARLET.MLB and the file PSLDEF.H in SYS\$STARLET_C.TLB define the following symbols and their values for the four access modes:

Value	Symbolic Name	Access Mode
0	PSL\$C_KERNEL	Kernel
1	PSL\$C_EXEC	Executive
2	PSL\$C_SUPER	Supervisor
3	PSL\$C_USER	User

The most privileged access mode used is the access mode of the caller. To unlock any specified page, the resultant access mode must be equal to or more privileged than the access mode of the owner of that page.

return_va_64

OpenVMS usage: address
type: quadword address
access: write only
mechanism: by 32- or 64-bit reference

The lowest process virtual address of the unlocked virtual address range. The *return_va_64* argument is the 32- or 64-bit virtual address of a naturally aligned quadword into which the service returns the virtual address.

return_length_64

OpenVMS usage: byte count
type: quadword (unsigned)
access: write only
mechanism: by 32- or 64-bit reference

The length of the virtual address range unlocked. The *return_length_64* argument is the 32- or 64-bit virtual address of a naturally aligned quadword into which the service returns the length of the virtual address range in bytes.

Description

The Unlock Pages from Memory service unlocks pages that were previously locked in memory by the Lock Pages in Memory (\$LCKPAG_64) service.

If the condition value SS\$_ACCVIO is returned by this service, a value *cannot* be returned in the memory locations pointed to by the *return_va_64* and *return_length_64* arguments.

If a condition value other than

SS\$_ACCVIO

is returned, the returned address and returned length indicate the pages that were successfully unlocked before the error occurred. If no pages were unlocked, the *return_va_64* argument will contain the value -1, and a value *cannot* be returned in the memory location pointed to by the *return_length_64* argument.

Required Privileges

To call the \$LCKPAG_64 service, a process must have PSWAPM privilege.

Required Quota

None.

Related Services

\$LCKPAG_64, \$LULKPAG

Condition Values Returned

SS\$_WASCLR

The service completed successfully. At least one of the specified pages was previously unlocked.

SS\$_WASSET

The service completed successfully. All of the specified pages were previously locked in the working set.

SS\$_ACCVIO

The *return_va_64* or *return_length_64* argument cannot be written by the caller, or an attempt was made to unlock pages by a caller whose access mode is less privileged than the access mode associated with the pages.

\$ULWSET

Unlock Pages from Working Set — Unlocks pages that were previously locked in the working set by the Lock Pages in Working Set (\$LKWSET) service.

Format

```
SYS$ULWSET inadr , [retadr] , [acmode]
```

C Prototype

```
int sys$ulwset  
    (struct _va_range *inadr, struct _va_range *retadr, unsigned int  
    acmode);
```

Arguments

inadr

OpenVMS usage: address_range
type: longword (unsigned)
access: read only
mechanism: by reference—array reference or descriptor

Starting and ending virtual addresses of the pages to be unlocked. The *inadr* argument is the address of a 2-longword array containing, in order, the starting and ending process virtual addresses.

Only the virtual page number portion of each virtual address is used; the low-order byte-within-page bits are ignored. If the starting and ending virtual address are the same, a single page is unlocked.

If more than one page is being unlocked and you need to determine specifically which pages had been previously unlocked, you should unlock the pages one at a time, that is, one page per call to \$ULWSET. The condition value returned by \$ULWSET indicates whether the page was previously unlocked.

On Alpha and Integrity server systems, if the first address in the 2-longword array is within an image mapped to your process, the entire image specified by the address is unlocked from the working set.

retadr

OpenVMS usage: address_range
type: longword (unsigned)
access: write only
mechanism: by reference—array reference or descriptor

Starting and ending process virtual addresses of the pages that were actually unlocked by \$CRMPSC. The *retadr* argument is the address of a 2-longword array containing, in order, the starting and ending process virtual addresses.

If an error occurs while multiple pages are being unlocked, *retadr* specifies those pages that were successfully unlocked before the error occurred. If no pages were successfully unlocked, both longwords in the *retadr* array contain the value -1.

On Alpha and Integrity server systems, if the *inadr* argument specifies an address within an image mapped to your process, *retadr* specifies only one range of pages unlocked from the working set. Many ranges of pages might be unlocked.

acmode

OpenVMS usage: access_mode
type: longword (unsigned)
access: read only
mechanism: by value

Access mode on behalf of which the request is being made. The *acmode* argument is a longword containing the access mode. The \$PSLDEF macro defines the symbols for the four access modes.

The most privileged access mode used is the access mode of the caller. To unlock any specified page, the resultant access mode must be equal to or more privileged than the access mode of the owner of that page.

Description

The Unlock Pages from Working Set service unlocks pages that were previously locked in the working set by the Lock Pages in Working Set (\$LKWSET) service. Unlocked pages become candidates for replacement within the working set of the process.

On Alpha and Integrity server systems, if the first address specified to SYSS\$ULWSET is within an image mapped to your process, a success status indicates that the entire image containing the specified address is either unlocked from the working set, or the count of times the image has been locked in the working set has been decremented. This behavior helps to ensure that privileged processes entering kernel mode and raising IPL higher than IPL 2 do not access an invalid page and cause a PGFIPLHI bugcheck. The system keeps a count of the number of times each image within your process has been locked in the working set. This count is maintained so that calls to SYSS\$ULWSET unlock the image only when it has been called the same number of times as SYSS\$LKWSET.

The LIBRTL routines LIB\$LOCK_IMAGE and LIB\$UNLOCK_IMAGE are preferable to SYSS\$LKWSET and SYSS\$ULWSET for locking and unlocking code and related data in the working set. For more information about locking images in the working set, see the LIBRTL manual and the description of LIB\$LOCK_IMAGE and LIB\$UNLOCK_IMAGE.

Required Access or Privileges

None

Required Quota

None

Related Services

\$ADJSTK, \$ADJWSL, \$CRETVA, \$CRMPSC, \$DELTVA, \$DGBLSC, \$EXPREG, \$LCKPAG, \$LKWSET, \$MGBLSC, \$PURGWS, \$SETPRT, \$SETSTK, \$SETSWM, \$ULKPAG, \$UPDSEC, \$UPDSECW

Condition Values Returned

SS\$_WASCLR

The service completed successfully. At least one of the specified pages was previously unlocked.

SS\$_WASSET

The service completed successfully. All of the specified pages were previously locked in the working set.

If the image has been locked in the working set, the count of times the image has been locked in the working set has been decremented. Only when the count is zero is the image unlocked from the working set.

SS\$_ACCVIO

The *inadr* argument cannot be read by the caller; the *retadr* argument cannot be written by the caller; or a page in the specified range is inaccessible or does not exist.

SS\$_NOPRIV

A page in the specified range is in the system address space.

\$ULWSET_64 (Alpha and Integrity servers)

Unlock Pages from Working Set — On Alpha and Integrity server systems, unlocks a virtual address range that was previously locked in the working set by the Lock Pages in Working Set (\$LKWSET_64) service. This service accepts 64-bit addresses.

Format

```
SYS$ULWSET_64
  start_va_64 , length_64 , acmode , return_va_64 , return_length_64
```

C Prototype

```
int sys$ulwset_64
(void *start_va_64, unsigned __int64 length_64, unsigned int acmode,
 void *(*return_va_64), unsigned __int64 *return_length_64);
```

Arguments

start_va_64

OpenVMS usage: address

type: quadword address
 access: read only
 mechanism: by value

The starting virtual address of the pages to be unlocked from the working set. The specified virtual address will be rounded down to a CPU-specific page boundary.

length_64

OpenVMS usage: byte count
 type: quadword (unsigned)
 access: read only
 mechanism: by value

Length of the virtual address space to be unlocked from the working set. The specified length will be rounded up to a CPU-specific page boundary so that it includes all CPU-specific pages in the requested range.

acmode

OpenVMS usage: access_mode
 type: longword (unsigned)
 access: read only
 mechanism: by value

Access mode on behalf of which the request is being made. The *acmode* argument is a longword containing the access mode.

The \$PSLDEF macro in STARLET.MLB and the file PSLDEF.H in SYS\$STARLET_C.TLB define the following symbols and their values for the four access modes:

Value	Symbolic Name	Access Mode
0	PSL\$C_KERNEL	Kernel
1	PSL\$C_EXEC	Executive
2	PSL\$C_SUPER	Supervisor
3	PSL\$C_USER	User

The most privileged access mode used is the access mode of the caller. To unlock any specified page, the resultant access mode must be equal to or more privileged than the access mode of the owner of that page.

return_va_64

OpenVMS usage: address
 type: quadword address
 access: write only
 mechanism: by 32- or 64-bit reference

The lowest process virtual address of the unlocked virtual address range. The *return_va_64* argument is the 32- or 64-bit virtual address of a naturally aligned quadword into which the service returns the virtual address.

return_length_64

OpenVMS usage: byte count
type: quadword (unsigned)
access: write only
mechanism: by 32- or 64-bit reference

The length of the virtual address range unlocked. The *return_length_64* argument is the 32- or 64-bit virtual address of a naturally aligned quadword into which the service returns the length of the virtual address range in bytes.

Description

The Unlock Pages from Working Set service unlocks pages that were previously locked in the working set by the Lock Pages in Working Set (\$LKWSET_64) service. Unlocked pages become candidates for replacement within the working set of the process.

If the condition value SS\$_ACCVIO is returned by this service, a value *cannot* be returned in the memory locations pointed to by the *return_va_64* and *return_length_64* arguments.

If a condition value other than SS\$_ACCVIO is returned, the returned address and returned length indicate the pages that were successfully unlocked before the error occurred. If no pages were unlocked, the *return_va_64* argument will contain the value -1, and a value *cannot* be returned in the memory location pointed to by the *return_length_64* argument.

On Alpha and Integrity server systems, if the first address specified to SY\$_ULWSET_64 is within an image mapped to your process, a success status indicates that the entire image containing the specified address is either unlocked from the working set, or the count of times the image has been locked in the working set has been decremented. This behavior helps to ensure that privileged processes entering kernel mode and raising IPL higher than IPL 2 do not access an invalid page and cause a PGFIPLHI bugcheck. The system keeps a count of the number of times each image within your process has been locked in the working set. This count is maintained so that calls to SY\$_ULWSET_64 unlock the image only when it has been called the same number of times as SY\$_LKWSET_64.

The LIBRTL routines LIB\$LOCK_IMAGE and LIB\$UNLOCK_IMAGE are preferable to SY\$_LKWSET_64 and SY\$_ULWSET_64 for locking and unlocking code and related data in the working set. For more information about locking images in the working set, see the LIBRTL manual and the description of LIB\$LOCK_IMAGE and LIB\$UNLOCK_IMAGE.

Required Privileges

None

Required Quota

None

Related Services

\$LKWSET_64, \$PURGE_WS, \$ULWSET

Condition Values Returned

SS\$_WASCLR

The service completed successfully. At least one of the specified pages was previously unlocked.

SS\$_WASSET

The service completed successfully. All of the specified pages were previously locked in the working set.

If the image had been locked in the working set, the count of times the image has been locked in the working set has been decremented. Only when the count is zero is the image unlocked from the working set.

SS\$_ACCVIO

The *return_va_64* or *return_length_64* argument cannot be written by the caller, or an attempt was made to unlock pages by a caller whose access mode is less privileged than the access mode associated with the pages.

SS\$_PAGNOTINREG

A page in the specified range is not within process private address space.

\$UNWIND

Unwind Call Stack — Unwinds the procedure call stack.

Format

```
SYS$UNWIND [depadr] , [newpc]
```

C Prototype

```
int sys$unwind (unsigned int *depadr, void *newpc);
```

Arguments

depadr

OpenVMS usage: longword_unsigned
type: longword (unsigned)
access: read only
mechanism: by reference

Depth to which the procedure call stack is to be unwound. The *depadr* argument is the address of a longword value. The value 0 specifies the call frame of the procedure that was executing when the condition occurred (that is, no call frames are unwound); the value 1 specifies the caller of that frame; the value 2 specifies the caller of the caller of that frame, and so on.

If *depadr* specifies the value 0, no unwind occurs and \$UNWIND returns a successful condition value in R0.

If you do not specify *depadr* (or with some languages you specify an address of 0), \$UNWIND unwinds the stack to the call frame of the procedure that called the procedure that established the condition handler that is calling the \$UNWIND service. This is the default and the normal method of unwinding the procedure call stack.

newpc

OpenVMS usage: address
type: longword (unsigned)
access: read only
mechanism: by value

New value for the program counter (PC); this value replaces the current value of the PC in the call frame of the procedure that receives control when the unwinding operation is complete. The *newpc* argument is a longword value containing the address at which execution is to resume.

Execution resumes at this address when the unwinding operation is complete.

If you do not specify *newpc*, execution resumes at the location specified by the PC in the call frame of the procedure that receives control when the unwinding operation is complete.

Description

The Unwind Call Stack service unwinds the procedure call stack; that is, it removes a specified number of call frames from the stack. Optionally, it can return control to a new program counter (PC) unwinding the stack. The \$UNWIND service is intended to be called from within a condition-handling routine.

The actual unwind is not performed immediately. Rather, the return addresses in the call stack are modified so that, when the condition handler returns, the unwind procedure is called from each frame being unwound.

During the actual unwinding of the call stack, \$UNWIND examines each frame in the call stack to see if a condition handler has been declared. If a handler has been declared, \$UNWIND calls the handler with the condition value `SS$_UNWIND` (indicating that the call stack is being unwound) in the condition name argument of the signal array. When you call a condition handler with this condition value, that handler can perform any procedure-specific cleanup operations that might be required. After the condition handler returns, the call frame is removed from the stack.

Required Access or Privileges

None

Required Quota

None

Related Services

\$DCLCMH, \$SETEXV

Condition Values Returned

SS\$_NORMAL

The service completed successfully.

SS\$_ACCVIO

The call stack is not accessible to the caller. This condition is detected when the call stack is scanned to modify the return address.

SS\$_INSFRAME

There are insufficient call frames to unwind to the specified depth.

SS\$_NOSIGNAL

No signal is currently active for an exception condition.

SS\$_UNWINDING

An unwind operation is already in progress.

SS\$_EXPGFLQUOTA or other condition values that can be returned by SS\$EXPREG_64 (Integrity servers only)

The process exceeded its paging file quota while allocating memory to perform the unwind operation. As a result, no unwind is performed. The condition handler return proceeds as though \$UNWIND was not called.

\$UPDSEC

Update Section File on Disk — Writes all modified pages in an active private or global section back into the section file on disk. One or more I/O requests are queued, based on the number of pages that have been modified.

Format

```
SYS$UPDSEC  
  inadr , [retadr] , [acmode] , [updflg] , [efn] , [iosb] , [astadr] , [astprm]
```

C Prototype

```
int sys$updsec  
(struct _va_range *inadr, struct _va_range *retadr, unsigned int acmode,  
 char updflg, unsigned int efn, struct _iosb *iosb,  
 void (*astadr)(__unknown_params), int astprm);
```

Arguments

inadr

OpenVMS usage: address_range

type: longword (unsigned)
access: read only
mechanism: by reference—array reference or descriptor

Starting and ending virtual addresses of the pages that are to be written to the section file if they have been modified. The *inadr* argument is the address of a 2-longword array containing, in order, the starting and ending process virtual addresses. Addresses are adjusted up or down to CPU-specific pages.

Only the virtual page number portion of each virtual address is used; the low-order byte-within-page bits are ignored.

\$UPDSEC scans pages starting at the address contained in the first longword specified by *inadr* and ending at the address contained in the second longword. Within this range, \$UPDSEC locates read/write pages that have been modified and writes them (contiguously, if possible) to the section file on disk. Unmodified pages are also written to disk if they share the same cluster with modified pages.

If the starting and ending virtual addresses are the same, a single page is written to the section file if the page has been modified.

The address specified by the second longword might be smaller than the address specified by the first longword.

retadr

OpenVMS usage: address_range
type: longword (unsigned)
access: write only
mechanism: by reference—array reference or descriptor

Addresses of the first and last pages that were actually queued for writing, in the first \$QIO request, back to the section file on disk. The *retadr* argument is the address of a 2-longword array containing, in order, the addresses of the first and last pages. Addresses always are adjusted up or down to fall on CPU-specific boundaries.

If \$UPDSEC returns an error condition value in R0, each longword specified by *retadr* contains the value -1. In this case, an event flag is not set, no asynchronous system trap (AST) is delivered, and the I/O status block is not written to.

acmode

OpenVMS usage: access_mode
type: longword (unsigned)
access: read only
mechanism: by value

Access mode on behalf of which the service is performed. The *acmode* argument is a longword containing the access mode. The \$PSLDEF macro defines the symbols for the four access modes.

The most privileged access mode used is the access mode of the caller. A page cannot be written to disk unless the access mode used by \$UPDSEC is equal to or more privileged than the access mode of the owner of the page to be written.

updflg

OpenVMS usage: longword_unsigned
type: longword (unsigned)
access: read only
mechanism: by value

Update specifier for read/write global sections. The *updflg* argument is a longword value. The value 0 (the default) specifies that all read/write pages in the global section are to be written to the section file on disk, whether or not they have been modified. The value 1 specifies that the caller is the only or the last process having the global section mapped for write access and that only modified pages should be written to the section file on disk.

efn

OpenVMS usage: ef_number
type: longword (unsigned)
access: read only
mechanism: by value

Event flag to be set when the section file on disk is actually updated. The *efn* argument is a longword specifying the number of the event flag; however, \$UPDSEC uses only the low-order byte.

If you do not specify *efn*, event flag 0 is used.

When you invoke \$UPDSEC, the specified event flag or event flag 0 is cleared; when the update operation is complete, the event flag is set.

iosb

OpenVMS usage: io_status_block
type: quadword (unsigned)
access: write only
mechanism: by reference

I/O status block to receive the final completion status of the updating operation. The *iosb* argument is the address of the quadword I/O status block.

When you invoke \$UPDSEC, the I/O status block is cleared. After the update operation is complete, that is, when all I/O to the disk is complete, the I/O status block is written as follows:

- The first word contains the condition value returned by \$QIO, indicating the final completion status.
- The first bit in the second word is set only if an error occurred during the I/O operation and the error was a hardware write error. The remaining bits of the second word are zeros.
- The second longword contains the virtual address of the first page that was not written.

Though this argument is optional, VSI strongly recommends that you specify it for the following reasons:

- If you are using an event flag to signal the completion of the service, you can test the I/O status block for a condition value to be sure that the event flag was not set by an event other than service completion.

- If you are using \$SYNCH to synchronize completion of the service, the I/O status block is a required argument for \$SYNCH.
- The condition value returned in R0 and the condition value returned in the I/O status block provide information about different aspects of the call to \$UPDSEC. The condition value returned in R0 gives you information about the success or failure of the service call itself; the condition value returned in the I/O status block gives you information about the success or failure of the service operation. Therefore, to accurately assess the success or failure of the call to \$UPDSEC, you must check the condition values returned in both R0 and the I/O status block.

astadr

OpenVMS usage: ast_procedure
type: procedure value
access: call without stack unwinding
mechanism: by reference—procedure reference or descriptor

AST routine to be executed when the section file has been updated. The *astadr* argument is the address of this routine.

If you specify *astadr*, the AST routine executes at the access mode from which the section file update was requested.

astprm

OpenVMS usage: user_arg
type: longword (unsigned)
access: read only
mechanism: by value

AST parameter to be passed to the AST routine. The *astprm* argument is this longword parameter.

Description

The Update Section File on Disk service writes all modified pages in an active private or global section back into the section file on disk. One or more I/O requests are queued, based on the number of pages that have been modified.

Proper use of this service requires the caller to synchronize completion of the update request. You do this by first checking the condition value returned in R0 by \$UPDSEC. If SSS\$_NOTMODIFIED is returned, the caller can continue. If SSS\$_NORMAL is returned, the caller should wait for the I/O to complete and then check the first word of the I/O status block for the final completion status. You can use the Synchronize (\$SYNCH) service to determine whether the I/O operation has actually completed.

Required Access or Privileges

None

Required Quota

\$UPDSEC uses the calling process's direct I/O limit (DIRIO) quota in queuing the I/O request and uses the calling process's AST limit (ASTLM) quota if the *astadr* argument is specified.

Related Services

\$ADJSTK, \$ADJWSL, \$CRETVA, \$CRMPSC, \$DELTVA, \$DGBLSC, \$EXPREG, \$LCKPAG, \$LKWSET, \$MGBLSC, \$PURGWS, \$SETPRT, \$SETSTK, \$SETSWM, \$ULKPAG, \$ULWSET, \$UPDSECW

Condition Values Returned

SS\$_NORMAL

The service completed successfully. One or more I/O requests were queued.

SS\$_NOTMODIFIED

The service completed successfully. No pages in the input address range were section pages that had been modified. No I/O requests were queued.

SS\$_ACCVIO

The input address array cannot be read by the caller, or the output address array cannot be written by the caller.

SS\$_EXQUOTA

The process has exceeded its AST limit quota.

SS\$_ILLEFC

You specified an illegal event flag number.

SS\$_IVSECFLG

You specified an invalid flag.

SS\$_NOPRIV

A page in the specified range is in the system address space.

SS\$_PAGOWNVIO

A page in the specified range is owned by an access mode more privileged than the access mode of the caller.

SS\$_UNASCEFC

The process is not associated with the cluster containing the specified event flag.

\$UPDSECW

Update Section File on Disk and Wait — Writes all modified pages in an active private or global section back into the section file on disk. One or more I/O requests are queued, based on the number of pages that have been modified. The \$UPDSECW service completes synchronously; that is, it returns to the

caller after writing all updated pages. For asynchronous completion, use the Update Section File on Disk (\$UPDSEC) service; \$UPDSEC returns to the caller after queuing the update request, without waiting for the pages to be updated. In all other respects, \$UPDSECW is identical to \$UPDSEC. For all other information about the \$UPDSECW service, refer to the description of \$UPDSEC. For additional information about system service completion, refer to the Synchronize (\$SYNCH) service.

Format

```
SY$UPDSECW
  inadr [,retadr] [,acmode] [,updfldg] [,efn] [,iosb] [,astadr] [,astprm]
```

C Prototype

```
int sys$updsecw
  (struct _va_range *inadr, struct _va_range *retadr, unsigned int acmode,
   char updfldg, unsigned int efn, struct _iosb *iosb,
   void (*astadr)(__unknown_params), int astprm);
```

\$UPDSEC_64 (Alpha and Integrity servers)

Update Global Section File on Disk — On Alpha and Integrity server systems, writes all pages (or only those pages modified by the current process) in an active private or global disk file section back into the section file on disk. One or more I/O requests are queued to perform the write operation. The \$UPDSEC_64 service completes asynchronously. For synchronous completion, use the Update Global Section File on Disk and Wait (\$UPDSEC_64W) service. This service accepts 64-bit addresses.

Format

```
SY$UPDSEC_64
  start_va_64 ,length_64 ,acmode ,updfldg ,efn ,iosa_64 ,return_va_64
  ,return_length_64 [,astadr_64 [,astprm_64]]
```

C Prototype

```
int sys$updsec_64
  (void *start_va_64, unsigned __int64 length_64, unsigned int acmode,
   unsigned int updfldg, unsigned int efn, struct _iosa *iosa_64,
   void *(*return_va_64), unsigned __int64 *return_length_64,...);
```

Arguments

start_va_64

OpenVMS usage: address
type: quadword address
access: read only
mechanism: by value

The starting virtual address of the pages to be written to the section file. The specified virtual address is rounded down to a CPU-specific page boundary.

length_64

OpenVMS usage: byte count
 type: quadword (unsigned)
 access: read only
 mechanism: by value

Length of the virtual address range to be written to the section file. The length specified is rounded up to a CPU-specific page boundary so that it includes all CPU-specific pages in the requested range.

acmode

OpenVMS usage: access_mode
 type: longword (unsigned)
 access: read only
 mechanism: by value

Access mode on behalf of which the service is performed. The *acmode* argument is a longword containing the access mode.

The \$PSLDEF macro in STARLET.MLB and the file PSLDEF.H in SYS\$STARLET_C.TLB define the following symbols and their values for the four access modes:

Value	Symbolic Name	Access Mode
0	PSL\$C_KERNEL	Kernel
1	PSL\$C_EXEC	Executive
2	PSL\$C_SUPER	Supervisor
3	PSL\$C_USER	User

The most privileged access mode used is the access mode of the caller. A page cannot be written to disk unless the access mode used by \$UPDSEC_64 is equal to or more privileged than the access mode of the owner of the page to be written.

updflg

OpenVMS usage: mask_longword
 type: longword (unsigned)
 access: read only
 mechanism: by value

The update specifier for read/write global sections. The *updflg* argument is a longword value. The value 0 (the default) specifies that all read/write pages in the global section are to be written to the section file on disk, whether or not they have been modified. The value UPDFLG\$M_WRT_MODIFIED specifies that the caller is the only process actually writing the global section and that only those pages that were actually modified by the caller are to be written to the section file on disk.

Definitions for this flag can be found in the file SECDEF.H in SYS\$STARLET_C.TLB for C and in \$SECDEF in STARLET.MLB for macro.

efn

OpenVMS usage: ef_number
type: longword (unsigned)
access: read_only
mechanism: by value

The event flag to be set when the section file on disk is actually updated. The *efn* argument is a longword specifying the number of the event flag; however, this service only uses the low-order byte. If you do not specify the *efn*, event flag 0 is used.

When you invoke \$UPDSEC_64, the specified event flag or event flag 0 is cleared. When the update operation is complete, the event flag is set.

iosa_64

OpenVMS usage: io_status_area
type: IOSA structure
access: write only
mechanism: by 32- or 64-bit reference

The I/O status area to receive the final completion status of the updating operation. The *iosa_64* argument is the 32- or 64-bit virtual address of the I/O status area. The I/O status area structure is 32 bytes in length. The I/O status area structure definition can be found in \$IOSADEF in STARLET.MLB for macro and in the file IOSADEF.H in SYS\$STARLET_C.TLB for C.

When you call SYS\$UPDSEC_64, the I/O status area is cleared. After the update operation is complete (that is, when all I/O to the disk is complete), the I/O status block is written as follows:

- *iosa\$l_status* (offset 0)

The first word contains the condition value return by SYS\$QIO, indicating the final completion status.

The first bit in the second word is set only if an error occurred during the I/O operation and the error was a hardware write error. The remaining bits of the second word are zeros.

- *iosa\$l_resd* (offset 4)

This field is reserved for future OpenVMS use. The value in this field is unpredictable.

- *iosa\$q_count_q* (offset 8)

This field is reserved for future OpenVMS use. The value in this field is unpredictable.

- *iosa\$ph_upsec_nowrt_va* (offset 16)

This field contains the virtual address of the first byte in the first disk block that was not written. In the case of an I/O error, this virtual address indicates the disk block for which the error occurred.

- *iosa\$q_resq* (offset 24)

This field is reserved for future OpenVMS use. The value in this field is unpredictable.

return_va_64

OpenVMS usage: address
type: quadword address
access: write only
mechanism: by 32- or 64-bit reference

The process virtual address of the first page that was actually queued for writing (in the first I/O request) back to the section file on the disk. The *return_va_64* argument is the 32- or 64-bit virtual address of a naturally aligned quadword into which the service returns the virtual address.

return_length_64

OpenVMS usage: byte count
type: quadword (unsigned)
access: write only
mechanism: by 32- or 64-bit reference

The length of the first I/O request to write modified pages back to the section file on disk. The *return_length_64* argument is the 32- or 64-bit virtual address of a naturally aligned quadword into which the service returns the length of the virtual address range, in bytes, written by the first I/O request.

astadr_64

OpenVMS usage: ast_procedure
type: procedure value
access: call without stack unwinding
mechanism: by 32- or 64-bit reference

The asynchronous system trap (AST) routine to be executed when the section file has been updated. The *astadr_64* argument is the 32- or 64-bit address of this routine. If you specify the *astadr_64* argument, the AST routine executes at the access mode from which the section file update was requested.

astprm_64

OpenVMS usage: user_arg
type: quadword
access: read only
mechanism: by value

The AST parameter to be passed to the AST routine. The *astprm_64* argument is a quadword argument that is passed to the AST routine.

Description

The Update Global Section File on Disk service writes all pages in an active private or global section back into the section file on disk. If the *updf1g* argument indicates that only modified pages are to be

written back to the disk file, only those global pages modified by the current process are queued to be written back into the section file on disk.

Proper use of this service requires the caller to synchronize completion of the update request. To do this, first check the condition value returned. If `SS$_NOTMODIFIED` is returned, the caller can continue. If `SS$_NORMAL` is returned, the caller should wait for the I/O to complete and then check the I/O status for final completion status.

If any error is returned by this service, a value **cannot** be returned in the memory locations pointed to by the `iosb_64`, `return_va_64`, and `return_length_64` arguments.

Required Privileges

None

Required Quota

`$UPDSEC_64` uses the calling process' direct I/O limit (DIRIO) quota in queuing the I/O request and uses the calling process' AST limit (ASTLM) quota if the `astadr_64` argument is specified.

Related Services

`$CRMPSC`, `$CRMPSC_FILE_64`, `$CRMPSC_GFILE_64`, `$CRMPSC_GPFILE_64`, `$MGBLSC_64`, `$UPDSEC`

Condition Values Returned

SS\$_NORMAL

The service completed successfully. One or more I/O requests were queued.

SS\$_NOTMODIFIED

The service completed successfully. No pages in the input address range were section pages that had been modified. No I/O requests were queued.

SS\$_ACCVIO

The `return_va_64`, `return_length_64`, or `iosb_64` argument cannot be written by the caller.

SS\$_EXASTLM

The process has exceeded its AST limit quota.

SS\$_EXBYTLM

The process has exceeded the byte count quota.

SS\$_ILLEFC

An illegal event flag number was specified.

SS\$_PAGNOTINREG

A page in the specified range is not within the process private address space.

SS\$_PAGOWNVIO

A page in the specified input address range is owned by a more privileged access mode.

SS\$_UNASCEFC

The process is not associated with the cluster containing the specified event flag.

\$UPDSEC_64W (Alpha and Integrity servers)

Update Global Section File on Disk and Wait — On Alpha and Integrity server systems, writes all modified pages in an active private or global disk file section back into the section file on disk. Zero or more I/O requests are queued, based on the number of pages that have been modified. The \$UPDSEC_64W service completes synchronously; that is, it returns to the caller after writing all updated pages. In all other respects, \$UPDSEC_64W is identical to \$UPDSEC_64. For additional information about the \$UPDSEC_64W service, see the description of \$UPDSEC_64 in this manual. This service accepts 64-bit addresses.

Format

```
SY$_UPDSEC_64W
    start_va_64 ,length_64 ,acmode ,updfg ,efn ,iosa_64 ,return_va_64
    ,return_length_64 [,astadr_64 [,astprm_64]]
```

C Prototype

```
int sys$updsec_64w
    (void *start_va_64, unsigned __int64 length_64, unsigned int acmode,
    unsigned int updfg, unsigned int efn, struct _iosa *iosa_64,
    void *(*return_va_64), unsigned __int64 *return_length_64,...);
```

\$VERIFY_PROXY

Verify a Proxy — Verifies that a proxy exists and returns a valid local user for the caller to use to create a local login.

Format

```
SY$_VERIFY_PROXY
    rem_node ,rem_user ,[proposed_user] ,local_user ,local_user_length
    ,[flags]
```

C Prototype

```
int sys$verify_proxy
    (void *rem_node, void *rem_user, void *proposed_user, void *local_user,
    unsigned short int *local_user_len, unsigned int flags);
```

Arguments

rem_node

OpenVMS usage: char_string
type: character-coded text string
access: read only
mechanism: by descriptor–fixed-length string descriptor

Remote node name of the proxy to be verified. The *rem_node* argument is the address of a character-string descriptor pointing to the remote node name string.

A remote node name consists of 1 to 1024 characters. No specific characters, format, or case are required for a remote node name string. All node names are converted to their DECnet for OpenVMS full name unless the PRX\$M_BYPASS_EXPAND flag is set with the *flags* argument.

Wildcards are not recognized. If you specify a wildcard character in the *rem_node* argument, it is ignored and assumed to be part of the requested node name.

rem_user

OpenVMS usage: char_string
type: character-coded text string
access: read only
mechanism: by descriptor–fixed-length string descriptor

Remote user name of the proxy to be verified. The *rem_user* argument is the address of a character-string descriptor pointing to the user name string.

A remote user name consists of 1 to 32 alphanumeric characters, including dollar signs (\$), underscores (_), and brackets ([]). Any lowercase characters specified are automatically converted to uppercase.

The *rem_user* argument can be specified in user identification code (UIC) format ([*group*, *member*]). Brackets are allowed only if the remote user name string specifies a UIC. Group and member are character-string representations of octal numbers with no leading zeros.

Wildcards are not allowed for the remote user specification. If wildcard characters are present in the string specified by the *rem_user* argument, the service returns SS\$_BADPARAM.

proposed_user

OpenVMS usage: char_string
type: character-coded text string
access: read only
mechanism: by descriptor–fixed-length string descriptor

Local user the caller suggests be used for the proxy login. The *proposed_user* argument is the address of a character-string descriptor pointing to the proposed local user name.

The proposed local user consists of 1 to 32 alphanumeric characters, including dollar signs (\$) and underscores (_). Any lowercase characters specified are automatically converted to uppercase.

See the Description section for information about the interaction of this argument with the return value of the *local_user* argument.

local_user

OpenVMS usage: char_string
 type: character-coded text string
 access: write only
 mechanism: by descriptor–fixed-length string descriptor

Local user the caller must use for a proxy login. The *local_user* argument is the address of a 32-byte character-string descriptor pointer to receive the local user name the caller must use for a proxy login for the proxy with the remote node name specified by the *rem_node* argument and the remote user name specified by the *rem_user* argument.

A local user name is a 32-character blank padded string of alphanumeric characters, including dollar signs (\$) and underscores (_).

local_user_length

OpenVMS usage: output length
 type: word (unsigned)
 access: write only
 mechanism: by reference

Length of the returned local user name in the *local_user* argument. The *local_user_length* argument is the address of an unsigned word to receive the length, in bytes, of the character string returned in the *local_user* argument.

flags

OpenVMS usage: mask_longword
 type: longword (unsigned)
 access: read only
 mechanism: by value

Functional specification for the service and type of user the *local_user* argument represents. The *flags* argument is a longword bit mask wherein each bit corresponds to an option.

Each flag option has a symbolic name. The \$PRXDEF macro defines the following symbolic name.

Symbolic Name	Description
PRX\$M_BYPASS_EXPAND	The service should not convert the node name specified in the <i>rem_node</i> argument to its corresponding DECnet for OpenVMS full name. If this flag is set, it is the caller's responsibility to ensure that the fully expanded node name is passed into the service.

Description

The Verify Proxy service verifies the existence of a proxy in the proxy database and returns the local user name the caller must use for any proxy logins.

The following description shows how the service determines which local user name the caller must use for proxy logins.

Proxies that match the remote node and remote user specified by the *rem_node* and *rem_user* arguments, respectively, are searched in the following order if the remote user name *is not* a UIC:

1. *rem_node::rem_user*
2. *::rem_user*
3. *rem_node::**
4. *::**

Proxies that match the remote node and remote user specified by the *rem_node* and *rem_user* arguments, respectively, are searched for in the following order if the remote user name *is* a UIC:

1. *rem_node::rem_user*
2. *::rem_user*
3. *rem_node::[group,*]*
4. *rem_node::*[*,member]*
5. *rem_node::*[*,*]*
6. *::**

The following table describes how the local user name the caller must use for any proxy logins is determined if a matching proxy record is found by the search.

Remote User	Proposed User	Proxy Default User	Proxy Local User Names	Returned Local User Name
<i>rem_user</i>	null	null	n/a	error
<i>rem_user</i>	null	default user	n/a	default user
<i>rem_user</i>	null	*	n/a	<i>rem_user</i>
<i>rem_user</i>	<i>prop_user</i>	default user	n/a	<i>prop_user</i>
<i>rem_user</i>	<i>prop_user</i>	default user	<i>prop_user</i>	<i>prop_user</i>
<i>rem_user</i>	<i>prop_user</i>	default user	local user	error
<i>rem_user</i>	<i>prop_user</i>	default user	*	<i>rem_user</i> if it equals <i>prop_user</i>
<i>rem_user</i>	<i>prop_user</i>	*	local user	<i>rem_user</i> if it equals <i>prop_user</i>

Required Access or Privileges

You must have SYSPRV privilege.

Required Quota

None

Related Services

\$ADD_PROXY, *\$DELETE_PROXY*, *\$DISPLAY_PROXY*

Condition Values Returned

SS\$_NORMAL

The service completed successfully.

SS\$_ACCVIO

The *rem_node*, *rem_user*, or *proposed_user* argument cannot be read by the service; or the *local_user* or *local_user_length* argument cannot be written by the service.

SS\$_BADBUFLN

The length of the *rem_node*, *rem_user*, *proposed_user*, or *local_user* argument was out of range.

SS\$_BADPARAM

The *rem_user* or *proposed_user* argument contains an invalid user name.

SS\$_NOREADALL

The caller does not have access to the proxy database.

This service can also return any of the following messages passed from the security server, or any OpenVMS RMS error message encountered during operations on the proxy database:

SECSRV\$_BADLOCALUSERLEN

The local user name length is out of range.

SECSRV\$_BADNODENAMELEN

The node name length is out of range.

SECSRV\$_BADREMUSERLEN

The remote user name length is out of range.

SECSRV\$_NOSUCHPROXY

The proxy specified by the *rem_node* and *rem_user* arguments does not exist in the proxy database.

SECSRV\$_NOSUCHUSER

No valid user was found for the requested proxy.

SECSRV\$_PROXYNOTACTIVE

Proxy processing is currently stopped. Try the request again later.

SECSRV\$_SERVERNOTACTIVE

The security server is not currently active. Try the request again later.

\$WAIT

Suspends Image Execution — The Wait service suspends image execution until an asynchronous record service completes. Upon completion of the service, RMS returns control to your program at the point following the Wait service call.

For additional information about this service, see the *VSI OpenVMS Record Management Services Reference Manual*.

\$WAITFR

Wait for Single Event Flag — Tests a specific event flag and returns immediately if the flag is set. Otherwise, the process is placed in a wait state until the event flag is set.

Format

```
SYS$WAITFR efn
```

C Prototype

```
int sys$waitfr (unsigned int efn);
```

Argument

efn

OpenVMS usage:	ef_number
type:	longword (unsigned)
access:	read only
mechanism:	by value

Number of the event flag for which to wait. The *efn* argument is a longword containing this number; however, \$WAITFR uses only the low-order byte.

Description

The Wait for Single Event Flag service tests a specific event flag and returns immediately if the flag is set. Otherwise, the process is placed in a wait state until the event flag is set. The wait state caused by this service can be interrupted by an asynchronous system trap (AST) if (1) the access mode at which the AST executes is equal to or more privileged than the access mode from which the \$WAITFR service was issued and (2) the process is enabled for ASTs at that access mode.

When a wait state is interrupted by an AST and after the AST service routine completes execution, the operating system repeats the \$WAITFR request on behalf of the process. At this point, if the event flag has been set, the process resumes execution.

Required Access or Privileges

None

Required Quota

None

Related Services

\$ASCEFC, \$CLREF, \$DACEFC, \$DLCEFC, \$READEF, \$SETEF, \$WFLAND, \$WFLOR

Condition Values Returned

SS\$_NORMAL

The service completed successfully.

SS\$_ILLEFC

You specified an illegal event flag number.

SS\$_UNASEFC

The process is not associated with the cluster containing the specified event flag.

\$WAKE

Wake Process from Hibernation — Activates a process that has placed itself in a state of hibernation with the Hibernate (\$HIBER) service. This service accepts 64-bit addresses.

Format

```
SY$WAKE [pidadr] , [prcnam]
```

C Prototype

```
int sys$wake (unsigned int *pidadr, void *prcnam);
```

Arguments

pidadr

OpenVMS usage: process_id
type: longword (unsigned)
access: modify
mechanism: by 32- or 64-bit reference

Process identification (PID) of the process to be activated. The *pidadr* argument is the 32- or 64-bit address of a longword that contains the PID. The *pidadr* argument can refer to a process running on the local node or a process running on another node in the cluster.

prcnam

OpenVMS usage: process_name

type: character-coded text string
access: read only
mechanism: by 32- or 64-bit descriptor – fixed-length string descriptor

Process name of the process to be activated. The *prcnam* argument is the 32- or 64-bit address of a 32- or 64-bit character string descriptor pointing to the process name. A process running on the local node can be identified with a 1 to 15 character string.

To identify a process on a particular node in a cluster, specify the full process name, which includes the node name as well as the process name. The full process name can contain up to 23 characters.

The process name is implicitly qualified by the UIC group number of the calling process. For this reason, you can use the *prcnam* argument only if the process to be activated is in the same UIC group as the calling process. To activate a process in another UIC group, you must specify the *pidadr* argument.

Description

The Wake Process from Hibernation service activates a process that has placed itself in a state of hibernation with the Hibernate (\$HIBER) service. If you specify neither the *pidadr* nor the *prcnam* argument, the wake request is issued for the calling process.

If the longword at address *pidadr* is the value 0, the PID of the target process is returned.

If one or more wake requests are issued for a process not currently hibernating, a subsequent hibernate request completes immediately; that is, the process does not hibernate. No count of outstanding wakeup requests is maintained.

You can also activate a hibernating process with the Schedule Wakeup (\$SCHDWK) service.

Required Access or Privileges

Depending on the operation, the calling process might need one of the following privileges to use \$WAKE:

- GROUP privilege to wake another process in the same group, unless the process has the same UIC as the calling process
- WORLD privilege to wake any other process in the system

Required Quota

None

Related Services

\$SCANEXH, \$CREPRC, \$DCLEXH, \$DELPRC, \$EXIT, \$FORCEX, \$GETJPI, \$GETJPIW, \$HIBER, \$PROCESS_SCAN, \$RESUME, \$SETPRI, \$SETPRN, \$SETPRV, \$SETRWM, \$SUSPND

Condition Values Returned

SS\$_NORMAL

The service completed successfully.

SS\$_ACCVIO

The process name string or string descriptor cannot be read by the caller, or the process identification cannot be written by the caller.

SS\$_INCOMPAT

The remote node is running an incompatible version of the operating system.

SS\$_IVLOGNAM

The specified process name string has a length of 0 or has more than 15 characters.

SS\$_NONEXPR

The specified process does not exist, or you specified an invalid process identification.

SS\$_NOPRIV

The process does not have the privilege to wake the specified process.

SS\$_NOSUCHNODE

The process name refers to a node that is not currently recognized as part of the VSMcluster system.

SS\$_NOSUCHTHREAD

The specified kernel thread does not exist.

SS\$_REMRSRC

The remote node has insufficient resources to respond to the request. (Bring this error to the attention of your system manager.)

SS\$_UNREACHABLE

The remote node is a member of the cluster but is not accepting requests. (This is normal for a brief period early in the system boot process.)

\$WFLAND

Wait for Logical AND of Event Flags — Allows a process to specify a set of event flags for which it wants to wait.

Format

```
SYS$WFLAND efn ,mask
```

C Prototype

```
int sys$wfland (unsigned int efn, unsigned int mask);
```

Arguments

efn

OpenVMS usage: `ef_number`
type: longword (unsigned)
access: read only
mechanism: by value

Number of any event flag within the event flag cluster to be used. The *efn* argument is a longword containing this number; however, \$WFLAND uses only the low-order byte. Specifying the number of an event flag within the cluster serves to identify the event flag cluster.

There are two local event flag clusters: cluster 0 and cluster 1. Cluster 0 contains event flag numbers 0 to 31, and cluster 1 contains event flag numbers 32 to 63.

There are two common event flag clusters: cluster 2 and cluster 3. Cluster 2 contains event flag numbers 64 to 95, and cluster 3 contains event flag numbers 96 to 127.

mask

OpenVMS usage: `mask_longword`
type: longword (unsigned)
access: read only
mechanism: by value

Event flags for which the process is to wait. The *mask* argument is a longword bit vector wherein a bit, when set, selects the corresponding event flag for which to wait.

Description

The Wait for Logical AND of Event Flags service allows a process to specify a set of event flags for which it wants to wait. The process is put in a wait state until all specified event flags are set, at which time \$WFLAND returns to the caller and execution resumes.

The wait state caused by this service can be interrupted by an asynchronous system trap (AST) if (1) the access mode at which the AST executes is equal to or more privileged than the access mode from which the \$WAITFR service was issued and (2) the process is enabled for ASTs at that access mode.

When a wait state is interrupted by an AST and after the AST service routine completes execution, the operating system repeats the \$WFLAND request on behalf of the process. At this point, if all the specified event flags have been set, the process resumes execution.

Required Access or Privileges

None

Required Quota

None

Related Services

\$ASCEFC, \$CLREF, \$DACEFC, \$DLCEFC, \$READEF, \$SETEF, \$WAITFR, \$WFLOR

Condition Values Returned

SS\$_NORMAL

The service completed successfully.

SS\$_ILLEFC

You specified an illegal event flag number.

SS\$_UNASEFC

The process is not associated with the cluster containing the specified event flag.

\$WFLOR

Wait for Logical OR of Event Flags — Allows a process to specify a set of event flags for which it wants to wait.

Format

```
SYS$WFLOR efn ,mask
```

C Prototype

```
int sys$wflor (unsigned int efn, unsigned int mask);
```

Arguments

efn

OpenVMS usage: ef_number
type: longword (unsigned)
access: read only
mechanism: by value

Number of any event flag within the event flag cluster to be used. The *efn* argument is a longword containing this number; however, \$WFLOR uses only the low-order byte. Specifying the number of an event flag within the cluster serves to identify the event flag cluster.

There are two local event flag clusters: cluster 0 and cluster 1. Cluster 0 contains event flag numbers 0 to 31, and cluster 1 contains event flag numbers 32 to 63.

There are two common event flag clusters: cluster 2 and cluster 3. Cluster 2 contains event flag numbers 64 to 95, and cluster 3 contains event flag numbers 96 to 127.

mask

OpenVMS usage: mask_longword
type: longword (unsigned)

access: read only
mechanism: by value

Event flags for which the process is to wait. The *mask* argument is a longword bit vector wherein a bit, when set, selects the corresponding event flag for which to wait.

Description

The Wait for Logical OR of Event Flags service allows a process to specify a set of event flags for which it wants to wait. The process is put in a wait state until any one of the specified event flags is set, at which time \$WFLOOR returns to the caller and execution resumes.

The wait state caused by this service can be interrupted by an asynchronous system trap (AST) if (1) the access mode at which the AST executes is equal to or more privileged than the access mode from which the \$WFLOOR service was issued and (2) the process is enabled for ASTs at that access mode.

When a wait state is interrupted by an AST and after the AST service routine completes execution, the operating system repeats the \$WFLOOR request on behalf of the process. At this point, if any of the specified event flags has been set, the process resumes execution.

Required Access or Privileges

None

Required Quota

None

Related Services

\$ASCEFC, \$CLREF, \$DACEFC, \$DLCEFC, \$READEF, \$SETEF, \$WAITFR, \$WFLAND

Condition Values Returned

SS\$_NORMAL

The service completed successfully.

SS\$_ILLEFC

You specified an illegal event flag number.

SS\$_UNASEFC

The process is not associated with the cluster containing the specified event flag.

\$WRITE

Transfers Bytes to File — The Write service transfers a user-specified number of bytes (beginning on a block boundary) to an RMS file of any file organization.

For additional information about this service, see the *VSI OpenVMS Record Management Services Reference Manual*.

Appendix A. Obsolete Services

The following table lists the obsolete system services and the current services that have replaced them.

Obsolete Service	Current Service
\$BRDCST	\$BRKTHRU, \$BRKTHRUW
\$CHANGE_ACL	\$GET_SECURITY, \$SET_SECURITY
\$CNTREG	\$DELTVA
\$CRELOG	\$CRELNM
\$DELLOG	\$DELLNM
\$GETCHN	\$GETDVI, \$GETDVIW
\$GETDEV	\$GETDVI, \$GETDVIW
\$INPUT	\$QIO, \$QIOW
\$OUTPUT	\$QIO, \$QIOW
\$SETSFM	This service is still supported but its use is discouraged.
\$SETSSF	This service is still supported but its use is discouraged.
\$SNDACC	\$SNDJBC, \$SNDJBCW
\$SND SMB	\$SNDJBC, \$SNDJBCW
\$STRNLOG	\$STRNLNM

